



Σύστημα ανοιγομένων με έμφαση στις πολλές κατασκευαστικές λύσεις και τις πολλές επιλογές αισθητικής.

Τα 10 δυνατά σημεία του συστήματος :

1. Το σύστημα M15000 PRESTIGE είναι πιστοποιημένο από το διεθνούς φήμης γερμανικό ινστιτούτο IFT ROSENHEIM, όσον αφορά την υδατοστεγανότητα και την ανεμοπερατότητα στις υψηλότερες κατηγορίες.
2. Η διαδικασία βαφής του συστήματος είναι πιστοποιημένη και διενεργείται σύμφωνα με τα Ευρωπαϊκά πρότυπα βαφής QUALICOAT και GSB.
3. Ο σχεδιασμός, η διαδικασία παραγωγής, και ο έλεγχος ποιότητας όλων των διατομών του συστήματος έχουν πιστοποιηθεί σύμφωνα με το διεθνές πρότυπο EN ISO 9001:2000.
4. Μεγάλη ποικιλία σχεδίων για τις εσωτερικές και εξωτερικές επιφάνειες του κουφώματος.
5. Μεγάλο κανάλι αποστράγγισης και αερισμού, καθαροί θάλαμοι για στιβαρή σύνδεση στη γωνία, απόσταση φύλλου κάσας 5mm για την αποφυγή “κοπής” του λάστιχου στα σημεία των μεντεσέδων, με αποτέλεσμα την υψηλή ηχομόνωση και τη στεγάνωση σε τρία επίπεδα, ακόμα και στα σημεία των μεντεσέδων.
6. Είσοδοι με μεντεσέδες βαρέως τύπου.
7. Παράθυρα τύπου “block” (κρυφά).
8. Ειδικά ενισχυμένα προφίλ για κατασκευή βιτρινών.
9. Μπαλκονόπορτα “χαμηλής διέλευσης”.
10. Δυνατότητα χρήσης μηχανισμού περιμετρικής ασφάλισης.

ΤΕΧΝΙΚΑ ΧΑΡΑΚΤΗΡΙΣΤΙΚΑ ΤΟΥ ΣΥΣΤΗΜΑΤΟΣ

Κράμα αλουμινίου	AlMgSi (EN AW 6060)
Σκληρότητα	12 Webster ή 70 HB minimum
Ελάχιστο πάχος βαφής	75 μm minimum
Πάχος διατομών (min-max)	1,6 - 2,5 mm
Έλεγχος διαστάσεων διατομών	EN DIN 12020-2
Πλάτος βασικής κάσας / βασικού φύλλου	50/59 mm
Είδος υαλοπίνακα που μπορεί να δεχθεί	Μονός ή διπλός, από 4 έως 38 mm
Μέγιστο βάρος υαλοπινάκων	Παραθύρου: Με απλό μεντεσέ έως 75 Kg / φύλλο Παραθύρου: Με ενίσχυση του μεντεσέ έως 130 Kg Εισόδου: Με μεντεσέ βαρέως τύπου έως 150 Kg
Είδος στεγάνωσης	Τριών επιπέδων, με κεντρική στεγάνωση “Aluseal” και ελαστικά από EPDM

Architectural system for doors and windows with a wide variety of applications

10 Added - value features :

1. M15000 PRESTIGE has been certified by IFT ROSENHEIM, to reach Class C sealing and Class E impermeability.
2. The process of electrostatic powder coating is certified with the European Standards QUALICOAT and GSB.
3. The design, the production process, and the quality control are certified with EN ISO 9001:2000.
4. Wide variety of applications and decorative designs.
5. Large air chamber for efficient drainage and ventilation. Clean interior chambers for stable corner connections. Designed to receive three continuous sealings even around hinges, resulting in higher sound and water insulation.
6. Entrance doors with heavy - duty hinges
7. Windows with concealed sash.
8. Reinforced profiles for store - front applications.
9. Balcony doors with discrete thresholds.
10. Turn and tilt mechanism with mushroom bolts and multi - locking points for high security requirements.

SYSTEM TECHNICAL SPECIFICATIONS	
Aluminium alloy extruded	AlMgSi (EN AW 6060)
Hardness	12 Webster ή 70 HB minimum
Minimum powder coating thickness	75 µm minimum
Profile thickness (min-max)	1,6 - 2,5 mm
Profile Geometry Control	EN DIN 12020-2
Basic frame width / Basic sash width	50/59 mm
Supporting glazing	Single, double, from 4 up to 38 mm
Maximum glazing weight	Window: 75 kg with simple hinges Window: 130 kg with heavy - duty hinges Door: 150 kg with heavy - duty hinges
Sealing and impermeability	“ALUSEAL” system, with EPDM gaskets applied in 3 levels



CERTIFICATE

The TÜV CERT Certification Body of TÜV NORD CERT GmbH certifies in accordance with TÜV CERT procedures that

ALUMIL **ALUMIL MYLONAS SA**
Industrial Area of Stavros
611 00 Kilkis / Greece

has established and operates a fully management system for

**Design and development of Aluminium Systems,
Production and trade of mill finished, painted aluminium profiles and relevant accessories.**

An audit was performed, Report No. GR-0445/2006. Proof was also furnished that the system conforms according to **ISO 9001 : 2000 / EN ISO 9001 : 2000** and fulfilled the certificate is valid until **2009-08-01**. Certificate Registration No. **04 100 20000970-E9**. The company has been certified since **2000**.





2006.11.29/06-37-25

LICENCE CERTIFICATE

AUTHORIZATION TO USE THE QUALITY SIGN



This is to certify that

ALUMIL S.A., GR-Kilkis
Licence number: **108**

is authorized to use the quality sign which is a visual mark according to the REGULATIONS FOR THE USE OF THE QUALICOAT QUALITY SIGN FOR PRIME, LAQUER AND POWDER COATINGS ON ALUMINIUM FOR ARCHITECTURAL APPLICATIONS and is considered providing products meeting the requirements for SEASIDE Class.

Date of issue of the licence: **16.08.1999**
Period of validity of the licence: **by 31.12.2007**

Zürich, 1 September 2006

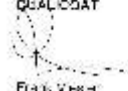

Frank Winkler
President

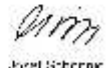

Jozef Schoppa
General Secretary

VERLEIHUNGS - URKUNDE CONFERMENT CERTIFICATE

DIE GSB INTERNATIONAL (GÜTEGEMEINSCHAFT FÜR DIE STÜCKBESCHICHTUNG VON BAUTEILEN E.V.), D-73525 SCHWABISCH GMÜND, verleiht hiermit aufgrund der Ihrem Güteauschuss vorliegenden Prüfberichte über die erforderliche Erprobung der Firma

The GSB INTERNATIONAL (GÜTEGEMEINSCHAFT FÜR DIE STÜCKBESCHICHTUNG VON BAUTEILEN E.V.), D-73525 SCHWABISCH GMÜND, in accordance with the test results and reports obtained by its Quality Committee pertaining to the Initial Test requirements, hereby confers on the company

**Alumil-Milonas
Aluminium Industry S.A.
Industrial Area
GR - 61100 Kilkis**

das Recht, das vom RAL Deutsches Institut für Gütesicherung und Kennzeichnung e.V. anerkannte und durch Eintragung beim Deutschen Patentamt warenzeichenrechtlich geschützte Gütezeichen zu führen.

the right to use the quality label which has been approved through RAL, Deutsches Institut fuer Gütesicherung und Kennzeichnung, and protected through registration with the German Patent Office.



Firmen-Nummer
registered company number

107

Die Führung des Gütezeichens setzt voraus, daß die Bestimmungen für dessen Verleihung und Führung ständig erfüllt werden.

Command to carry the quality label requires the ongoing and full compliance with the rules and regulations pertaining to its conferment.

D-73525 Schwabisch Gmünd, **July 15, 2003**



Vorsitzender
Chairman



Obmann des Güteausschusses
Head of the Quality Control

Πιστοποίηση Συγκόλλων Συστημάτων
MIS000 Prestige

Summary

of the analysis from Test Report 126 25793 (7)
dated October 26, 2006

For: **ALUMIL - Aluminium System
ALUMIL S.A. INDUSTRIAL AREA
61100 Kilkis**

For: **Aluminum and aluminum alloys, coating, epoxy resin, primer, base, intermediate and topcoat, surface finish, anti-rust products.**

Ref. to: **EN ISO 9000 Prestige**





















































INSTITUT FÜR
TÜBINGEN



















































Material	Class 1	Class 2	Class 3	Class 4
ANFÖRDRUNGSGRUPPE	Class 4	Class 4	Class 4	Class 4
VERGÜTUNGSGRUPPE	Class 4	Class 4	Class 4	Class 4
ANFÖRDRUNGSGRUPPE	Class 4	Class 4	Class 4	Class 4
ANFÖRDRUNGSGRUPPE	Class 4	Class 4	Class 4	Class 4
ANFÖRDRUNGSGRUPPE	Class 4	Class 4	Class 4	Class 4
ANFÖRDRUNGSGRUPPE	Class 4	Class 4	Class 4	Class 4





























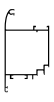



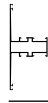













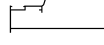







EN ISO 9000 PRESTIGE

**Ευρετήριο Προφίλ
Profile Index**

ΠΡΟΦΙΛ PROFILE	ΠΡΟΦΙΛ No / Profile No Βάρος / Weight (gr/m)	ΣΕΛΙΔΑ PAGE	ΠΡΟΦΙΛ PROFILE	ΠΡΟΦΙΛ No / Profile No Βάρος / Weight (gr/m)	ΣΕΛΙΔΑ PAGE	ΠΡΟΦΙΛ PROFILE	ΠΡΟΦΙΛ No / Profile No Βάρος / Weight (gr/m)	ΣΕΛΙΔΑ PAGE
	M 946 232	A10, B37		M 9368 592	A12, B31		M 11119 379	A09, B36
	M 6000 503	A09, B36		M 9379 1446	A03, B06		M 11226 228	A10, B39
	M 6039 197	A09, B37		M 9381 1036	A03, B06		M 11451 307	A10, B37
	M 6040 115	A09, B37		M 9393 1303	A11, B29		M 11452 314	A10, B38
	M 9300 756	A11, B28		M 9394 1384	A11, B29		M 11453 325	A10, B38
	M 9312 242	A10, B37		M 9395 944	A11, B28		M 11454 351	A10, B38
	M 9313 175	A10, B37		M 9398 631	A11, B28		M 11457 114	A10, B25
	M 9316 136	A11, B35		M 9399 1240	A11, B29		M 11462 298	A11, B38
	M 9317 181	A10, B39		M 9534 713	A12, B31		M 11463 313	A11, B38
	M 9338 470	A12, B30		M 9538 520	A12, B30		M 11464 332	A11, B39
	M 9338A 526	A12, B30		M 9553 582	A12, B30		M 11482 351	A10, B25
	M 9342 466	A12, B31		M 9558 483	A12, B30		M 15004 1111	A05, B12
	M 9348 280	A12, B32		M 9559 608	A12, B31		M 15005 1293	A05, B12
	M 9351 70	A11, B35		M 9564 604	A12, B29		M 15006 1210	A05, B12
	M 9353 511	A12, B30		M 9578 209	A11, B32		M 15008 863	A02, B02
	M 9356 670	A12, B31		M 11116 184	A10, B40		M 15010 951	A02, B02
	M 9357 385	A12, B31		M 11118 324	A09, B36		M 15012 1036	A02, B02

ΠΡΟΦΙΛ PROFILE	ΠΡΟΦΙΛ No / Profile No Βάρος / Weight (gr/m)	ΣΕΛΙΔΑ PAGE	ΠΡΟΦΙΛ PROFILE	ΠΡΟΦΙΛ No / Profile No Βάρος / Weight (gr/m)	ΣΕΛΙΔΑ PAGE	ΠΡΟΦΙΛ PROFILE	ΠΡΟΦΙΛ No / Profile No Βάρος / Weight (gr/m)	ΣΕΛΙΔΑ PAGE
	M 15013 1203	A02, B03		M 15036 1469	A03, B07		M 15074 1353	A07, B15
	M 15014 989	A02, B02		M 15040 1099	A04, B08		M 15076 1426	A04, B21
	M 15016 1074	A02, B02		M 15042 1261	A04, B09		M 15078 1079	A03, B21
	M 15018 1159	A02, B03		M 15044 1697	A04, B09		M 15080 1543	A03, B05
	M 15022 1092	A02, B03		M 15046 1207	A04, B09		M 15082 1962	A07, B17
	M 15024 1177	A02, B03		M 15050 1115	A04, B09		M 15083 1676	A07, B16
	M 15025 1589	A02, B04		M 15052 1280	A04, B10		M 15084 1832	A07, B16
	M 15026 1608	A02, B04		M 15054 1699	A04, B10		M 15085 1728	A07, B17
	M 15027 1572	A02, B04		M 15060 979	A06, B13		M 15086 1979	A07, B18
	M 15028 911	A05, B23		M 15062 1067	A06, B13		M 15088 1857	A07, B18
	M 15029 968	A05, B25		M 15064 1154	A06, B13		M 15090 825	A09, B33
	M 15030 1075	A03, B07		M 15065 1044	A06, B15		M 15092 575	A09, B33
	M 15031 1046	A03, B08		M 15066 1239	A06, B13		M 15094 935	A09, B33
	M 15032 1220	A03, B07		M 15067 2061	A07, B19		M 15096 682	A09, B33
	M 15033 1204	A03, B08		M 15068 1671	A06, B14		M 15098 895	A09, B34
	M 15034 1650	A03, B07		M 15070 1189	A07, B14		M 15100 691	A09, B34
	M 15035 1629	A03, B08		M 15071 943	A07, B14		M 15110 364	A11, B38

ΠΡΟΦΙΛ PROFILE	ΠΡΟΦΙΛ No / Profile No Βάρος / Weight (gr/m)	ΣΕΛΙΔΑ PAGE	ΠΡΟΦΙΛ PROFILE	ΠΡΟΦΙΛ No / Profile No Βάρος / Weight (gr/m)	ΣΕΛΙΔΑ PAGE	ΠΡΟΦΙΛ PROFILE	ΠΡΟΦΙΛ No / Profile No Βάρος / Weight (gr/m)	ΣΕΛΙΔΑ PAGE
	M 15117 205	A10, B40		M 15176 437	A08, B22		M 15375 1173	A06, B27
	M 15118 465	A09, B36		M 15180 342	A10, B33		M 15376 1220	A05, B26
	M 15119 481	A09, B36		M 15181 1240	A05, B11		M 15377 1239	A05, B26
	M 15120 432	A09, B36		M 15182 1449	A04, B21		M 15378 1303	A05, B26
	M 15128 1179	A05, B32		M 15183 928	A05, B22		M 15379 1083	A06, B27
	M 15132 1040	A06, B32		M 15185 304	A08, B22		M 15393 1416	A04, B11
	M 15142 1982	A07, B19		M 15190 1463	A04, B11		M 15408 987	A03, B23
	M 15143 2077	A07, B20		M 15191 751	A06, B21		M 15416 1225	A06, B24
	M 15150 2274	A03, B05		M 15192 1710	A07, B20		M 15417 1153	A06, B24
	M 15157 820	A08, B20		M 15195 568	A08, B35		M 15421 989	A05, B24
	M 15162 754	A07, B22		M 15200 853	A05, B24		M 15458 1370	A06, B25
	M 15170 611	A08, B20		M 15205 1147	A02, B06		M 15460 1196	A04, B11
	M 15171 505	A08, B22		M 15210 1053	A02, B02		M 15461 1581	A03, B05
	M 15172 281	A08, B34		M 15250 1221	A04, B10		M 15474 837	A08, B34
	M 15173 466	A08, B34		M 15266 1262	A06, B14		M 15575 653	A08, B23
	M 15174 188	A08, B39		M 15324 1821	A04, B10		M 15576 1157	A08, B23
	M 15175 209	A08, B22		M 15373 1282	A05, B26		M 15577 291	A08, B34

ΠΡΟΦΙΛ PROFILE	ΠΡΟΦΙΛ Νο / Profile No Βάρος / Weight (gr/m)	ΣΕΛΙΔΑ PAGE
	S 265 136	A10, B25
	T 50 577	A10, B33
	U 24x10 216	A11, B22

Προφίλ
Profile Overview
1:4

ΠΡΟΦΙΛ
PROFILE

ΠΡΟΦΙΛ No / Profile No
Βάρος / Weight (gr/m)

X mm
Y mm

Ix cm⁴
Jy cm⁴

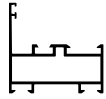

**M 15008
863**

50,00
48,00

4,29
10,14

**M 15010
951**

50,00
58,00

8,16
12,04

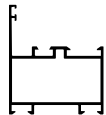

**M 15012
1036**

50,00
68,00

13,84
13,93

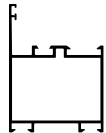

**M 15210
1053**

50,00
79,80

12,82
14,64

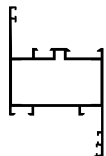

**M 15014
989**

59,00
48,20

5,76
15,36

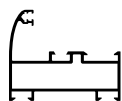

**M 15016
1074**

59,00
58,00

10,32
17,98

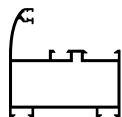

**M 15018
1159**

59,00
68,00

16,99
20,64

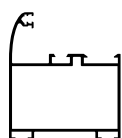

ΠΡΟΦΙΛ
PROFILE

ΠΡΟΦΙΛ No / Profile No
Βάρος / Weight (gr/m)

X mm
Y mm

Ix cm⁴
Jy cm⁴

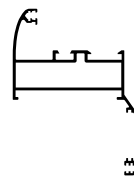

**M 15013
1203**

68,00
88,20

19,58
26,36

**M 15022
1092**

59,00
58,00

10,87
18,36

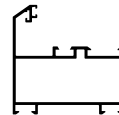

**M 15024
1177**

59,00
68,00

17,72
21,03

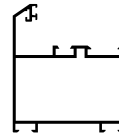

**M 15205
1147**

77,40
58,00

9,56
21,05

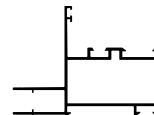

**M 15025
1589**

120,00
48,00

9,94
76,15

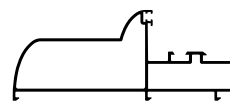

**M 15026
1608**

116,00
48,00

15,72
83,12

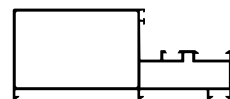

**M 15027
1572**

116,00
48,00

14,68
77,92

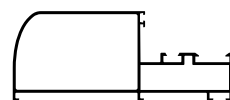

ΠΡΟΦΙΛ
PROFILE

ΠΡΟΦΙΛ No / Profile No
Βάρος / Weight (gr/m)

X mm
Y mm

Ix cm⁴
Jy cm⁴

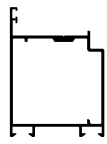

M 15078
1079

50,00
68,70

18,25
14,74

ΠΡΟΦΙΛ
PROFILE

ΠΡΟΦΙΛ No / Profile No
Βάρος / Weight (gr/m)

X mm
Y mm

Ix cm⁴
Jy cm⁴

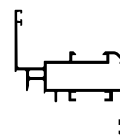

M 15030
1075

59,00
66,00

6,42
16,78

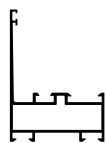

M 15408
987

50,00
70,00

11,32
11,89

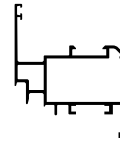

M 15032
1220

59,00
76,00

11,38
20,28

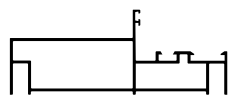

M 15080
1543

115,00
45,00

7,30
74,83

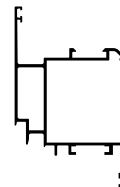

M 15036
1469

59,00
96,00

28,24
26,12



M 15150
2274

180,00
58,00

19,73
285,46

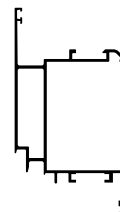

M 15034
1650

59,00
110,00

46,86
30,14

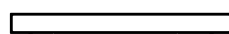

M 9381
1036

117,60
13,30

0,88
50,38

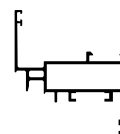

M 15031
1046

59,00
66,00

6,27
16,77



M 9379
1446

117,60
42,40

11,21
78,36

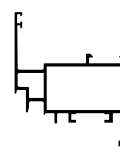

M 15033
1204

59,00
76,00

11,14
20,40

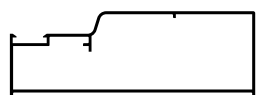

M 15461
1581

129,80
47,90

17,52
114,88

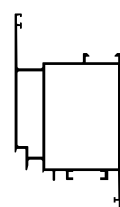

M 15035
1629

59,00
110,00

45,50
30,10

ΠΡΟΦΙΛ
PROFILE

ΠΡΟΦΙΛ No / Profile No
Βάρος / Weight (gr/m)

X mm
Y mm

Ix cm⁴
Jy cm⁴

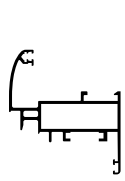

**M 15040
1099**

59,00
66,00

7,80
17,14

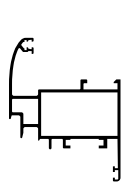

**M 15042
1261**

59,00
76,00

13,31
20,77

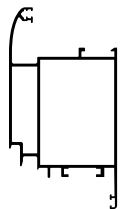

**M 15044
1697**

59,00
110,00

50,89
30,46

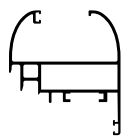

**M 15046
1207**

59,00
66,00

10,72
18,99

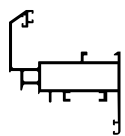

**M 15050
1115**

59,00
66,00

8,31
17,61

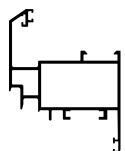

**M 15052
1280**

59,00
76,00

14,04
21,26

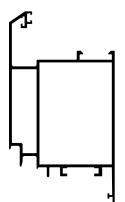

**M 15054
1699**

59,00
110,00

52,07
30,74

ΠΡΟΦΙΛ
PROFILE

ΠΡΟΦΙΛ No / Profile No
Βάρος / Weight (gr/m)

X mm
Y mm

Ix cm⁴
Jy cm⁴

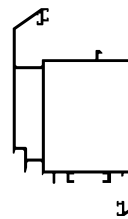

**M 15324
1821**

65,00
110,00

59,50
39,22

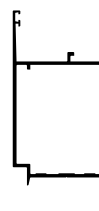

**M 15182
1449**

50,00
105,00

41,71
22,55

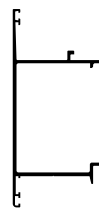

**M 15076
1426**

50,00
104,60

40,69
21,80

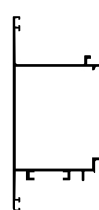

**M 15393
1416**

59,00
110,00

44,26
27,80

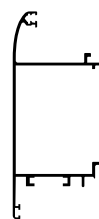

**M 15190
1463**

59,00
110,00

48,95
27,99

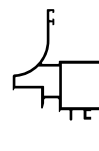

**M 15250
1221**

68,00
76,00

11,13
20,61

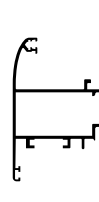

**M 15460
1196**

59,00
76,00

13,40
18,96

ΠΡΟΦΙΛ No / Profile No
PROFILE Βάρος / Weight (gr/m)

X mm
Y mm

$I_x \text{ cm}^4$
 $J_y \text{ cm}^4$

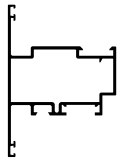

M 15128
1179

57,30
80,60

18,43
14,19

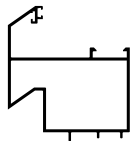

M 15181
1240

64,50
71,70

17,99
23,99

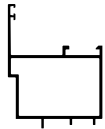

M 15183
928

50,00
65,80

10,35
11,92

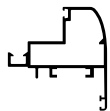

M 15028
911

52,50
54,90

5,69
8,77

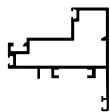

M 15421
989

53,50
54,90

6,13
11,78

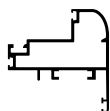

M 15029
968

53,50
54,90

5,66
11,37

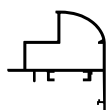

M 15200
853

52,10
54,90

5,57
7,68

ΠΡΟΦΙΛ No / Profile No
PROFILE Βάρος / Weight (gr/m)

X mm
Y mm

$I_x \text{ cm}^4$
 $J_y \text{ cm}^4$

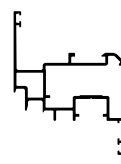

M 15377
1239

59,00
76,00

11,16
20,14

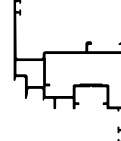

M 15376
1220

59,00
76,00

10,93
20,28

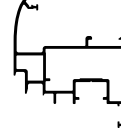

M 15373
1282

59,00
76,00

13,08
20,71

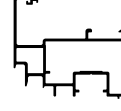

M 15378
1303

59,00
76,00

13,93
21,24

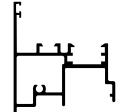

M 15004
1111

53,80
61,00

7,48
12,90

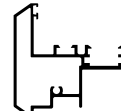

M 15005
1293

62,80
61,00

18,91
11,01

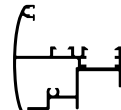

M 15006
1210

61,30
61,00

9,42
16,94

ΠΡΟΦΙΛ PROFILE
 ΠΡΟΦΙΛ No / Profile No
 Βάρος / Weight (gr/m)

X mm
 Y mm
 $I_x \text{ cm}^4$
 $J_y \text{ cm}^4$

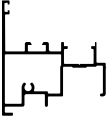
	M 15379	54,90	7,44
	1083	61,00	12,25

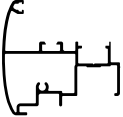
	M 15375	62,40	9,28
	1173	61,00	15,98

	M 15191	48,50	2,59
	751	39,00	6,86

	M 15132	50,00	7,81
	1040	60,00	10,63

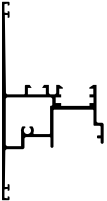
	M 15458	53,80	22,74
	1370	105,00	16,03

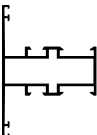
	M 15060	50,00	7,58
	979	70,00	11,24

	M 15062	50,00	12,85
	1067	80,00	13,22

ΠΡΟΦΙΛ PROFILE
 ΠΡΟΦΙΛ No / Profile No
 Βάρος / Weight (gr/m)

X mm
 Y mm
 $I_x \text{ cm}^4$
 $J_y \text{ cm}^4$

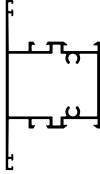
	M 15266	50,00	21,24
	1262	90,00	16,12

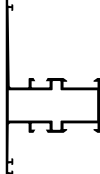
	M 15417	50,00	13,47
	1153	95,00	17,94

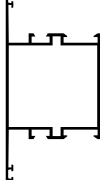
	M 15066	50,00	29,46
	1239	100,00	17,10

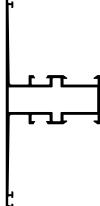
	M 15416	50,00	26,14
	1225	114,00	13,74

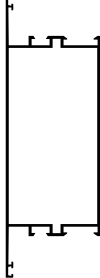
	M 15068	50,00	113,93
	1671	150,00	26,70

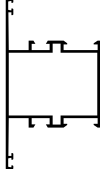
	M 15064	50,00	20,10
	1154	90,00	15,17

	M 15065	58,50	7,71
	1044	70,00	16,49

ΠΡΟΦΙΛ No / Profile No
PROFILE Βάρος / Weight (gr/m)

X mm
Y mm

Ix cm⁴
Jy cm⁴

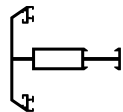
	M 15071 943	58,50 56,00	5,92 11,86
--	------------------------	----------------	---------------

	M 15070 1189	58,50 70,00	12,34 17,19
--	-------------------------	----------------	----------------

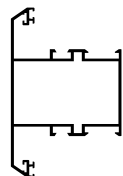
	M 15074 1353	58,50 90,00	28,65 22,59
--	-------------------------	----------------	----------------

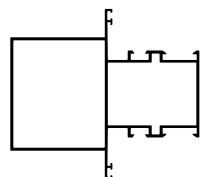
	M 15084 1832	100,00 90,00	36,22 68,14
--	-------------------------	-----------------	----------------

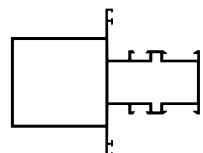
	M 15083 1676	100,00 78,00	21,48 58,85
--	-------------------------	-----------------	----------------

	M 15067 2061	59,00 150,00	140,14 43,61
--	-------------------------	-----------------	-----------------

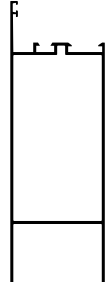
	M 15192 1710	50,00 150,00	117,16 29,12
--	-------------------------	-----------------	-----------------

ΠΡΟΦΙΛ No / Profile No
PROFILE Βάρος / Weight (gr/m)

X mm
Y mm

Ix cm⁴
Jy cm⁴

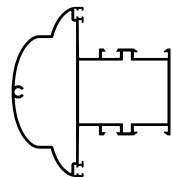
	M 15085 1728	84,10 90,00	36,33 41,45
--	-------------------------	----------------	----------------

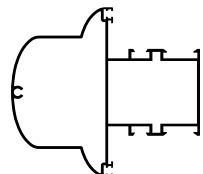
	M 15088 1857	100,00 90,00	40,41 62,09
--	-------------------------	-----------------	----------------

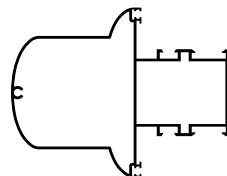
	M 15086 1979	115,00 90,00	44,26 89,21
--	-------------------------	-----------------	----------------

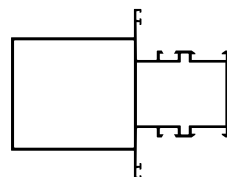
	M 15082 1962	115,00 90,00	40,32 97,46
--	-------------------------	-----------------	----------------

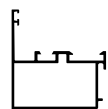
	M 15157 820	50,00 53,80	6,23 9,55
---	------------------------	----------------	--------------

	M 15142 1982	50,00 150,00	134,30 30,86
---	-------------------------	-----------------	-----------------

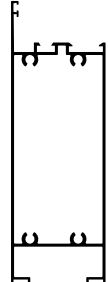
	M 15143 2077	50,00 150,00	165,31 32,08
---	-------------------------	-----------------	-----------------

ΠΡΟΦΙΛ PROFILE ΠΡΟΦΙΛ No / Profile No Βάρος / Weight (gr/m) X mm Y mm Ix cm⁴ Jy cm⁴

M 15170
611 56,30 1,88
32,75 9,89



M 15171
505 48,20 0,61
21,80 5,30



M 15474
837 64,40 2,59
34,65 11,94



M 15575
653 29,50 7,46
50,00 2,92



M 15576
1157 90,00 18,01
50,00 31,95

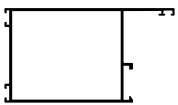

M 15162
754 47,90 4,24
43,80 8,27



M 15174
188 26,80 0,11
13,15 0,45



ΠΡΟΦΙΛ PROFILE ΠΡΟΦΙΛ No / Profile No Βάρος / Weight (gr/m) X mm Y mm Ix cm⁴ Jy cm⁴

M 15577
291 42,50 0,05
8,00 1,35



M 15172
281 36,70 0,06
10,00 1,42



M 15195
568 42,60 0,59
18,50 4,49



M 15173
466 45,80 0,41
23,50 4,48



M 15175
209 30,00 0,04
6,50 0,58



M 15176
437 70,00 0,09
6,50 7,05

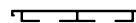

M 15185
304 43,40 0,17
18,30 1,93



ΠΡΟΦΙΛ
PROFILE

ΠΡΟΦΙΛ No / Profile No
Βάρος / Weight (gr/m)

X mm
Y mm

Ix cm⁴
Jy cm⁴



**M 11118
324**

33,10
42,80

2,79
0,82



**M 11119
379**

38,20
42,80

3,29
1,11



**M 15118
465**

54,35
52,50

5,91
4,46



**M 15119
481**

55,60
52,50

4,64
6,68

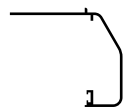

**M 6000
503**

59,60
52,50

5,18
7,38

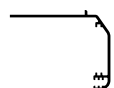

**M 15120
432**

53,20
42,30

3,40
3,97



**M 6039
197**

10,36
40,00

1,21
0,02

ΠΡΟΦΙΛ
PROFILE

ΠΡΟΦΙΛ No / Profile No
Βάρος / Weight (gr/m)

X mm
Y mm

Ix cm⁴
Jy cm⁴



**M 6040
115**

17,10
6,90

0,09
0,01

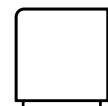

**M 15090
825**

53,00
53,00

12,18
12,18



**M 15092
575**

49,15
38,15

2,93
4,95

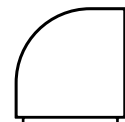

**M 15094
935**

62,00
62,00

17,61
17,61



**M 15096
682**

58,15
44,50

4,83
7,97

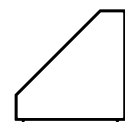

**M 15098
895**

62,00
62,00

14,51
14,51





**M 15100
691**

58,15
44,50

4,94
8,46

ΠΡΟΦΙΛ PROFILE ΠΡΟΦΙΛ No / Profile No Βάρος / Weight (gr/m) X mm Y mm Ix cm⁴ Jy cm⁴

	M 15180 342	50,00 21,35	0,24 4,09
---	------------------------------	----------------	--------------

	T 50 577	50,00 50,00	8,70 8,70
---	---------------------------	----------------	--------------

	M 11482 351	21,00 26,50	0,91 0,80
---	------------------------------	----------------	--------------

	M 11116 184	16,20 20,70	0,28 0,14
---	------------------------------	----------------	--------------

	M 15117 205	20,00 22,70	0,23 0,35
---	------------------------------	----------------	--------------

	M 9317 181	21,00 16,00	0,11 0,30
---	-----------------------------	----------------	--------------

	M 11226 228	26,60 19,80	0,25 0,48
---	------------------------------	----------------	--------------

	S 265 136	9,10 24,00	0,02 0,27
---	----------------------------	---------------	--------------

ΠΡΟΦΙΛ PROFILE ΠΡΟΦΙΛ No / Profile No Βάρος / Weight (gr/m) X mm Y mm Ix cm⁴ Jy cm⁴

	M 11457 114	9,10 19,00	0,01 0,15
---	------------------------------	---------------	--------------

	M 946 232	19,60 26,60	0,58 0,24
---	----------------------------	----------------	--------------

	M 9313 175	19,00 26,50	0,42 0,23
---	-----------------------------	----------------	--------------

	M 9312 242	19,35 26,50	0,68 0,32
---	-----------------------------	----------------	--------------

	M 11451 307	19,40 26,30	0,83 0,47
---	------------------------------	----------------	--------------

	M 11452 314	22,50 26,60	0,87 0,70
---	------------------------------	----------------	--------------

	M 11453 325	26,00 26,70	0,89 0,96
---	------------------------------	----------------	--------------

	M 11454 351	30,50 26,60	0,94 1,34
---	------------------------------	----------------	--------------

ΠΡΟΦΙΛ PROFILE ΠΡΟΦΙΛ No / Profile No Βάρος / Weight (gr/m) X mm Y mm Ix cm⁴ Jy cm⁴

	M 15110	34,50	0,98
	364	26,70	1,76

	M 11462	22,50	0,80
	298	26,70	0,59

	M 11463	26,50	0,84
	313	26,60	0,87

	M 11464	30,50	0,90
	332	26,70	1,17

	U 24x10	24,00	0,06
	216	10,00	0,61

	M 9300	45,00	3,43
	756	50,50	8,46

	M 9395	45,00	9,33
	944	62,00	10,65

ΠΡΟΦΙΛ PROFILE ΠΡΟΦΙΛ No / Profile No Βάρος / Weight (gr/m) X mm Y mm Ix cm⁴ Jy cm⁴

	M 9398	42,05	1,71
	631	40,30	4,84

	M 9351	16,90	-
	70	4,60	-

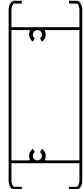
	M 9393	39,00	49,50
	1303	100,00	12,32

	M 9394	39,00	55,81
	1384	100,00	12,80

	M 9399	39,00	46,83
	1240	100,00	11,58

	M 9578	28,40	0,03
	209	9,00	0,59

	M 9316	18,90	-
	136	4,20	-

ΠΡΟΦΙΛ PROFILE
 ΠΡΟΦΙΛ No / Profile No
 Βάρος / Weight (gr/m)

X mm
 Y mm
 $I_x \text{ cm}^4$
 $J_y \text{ cm}^4$



**M 9338A
 526**

24,70
 77,20
 8,35
 1,68

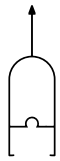

**M 9338
 470**

24,90
 80,00
 8,81
 1,44

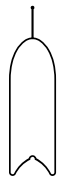

**M 9353
 511**

24,90
 90,00
 13,73
 1,84

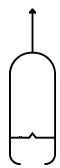

**M 9538
 520**

24,90
 82,90
 10,47
 1,75



**M 9558
 483**

24,90
 83,20
 10,84
 1,85

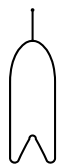

**M 9553
 582**

24,90
 82,30
 12,25
 1,94



**M 9368
 592**

24,90
 87,00
 12,71
 1,60

ΠΡΟΦΙΛ PROFILE
 ΠΡΟΦΙΛ No / Profile No
 Βάρος / Weight (gr/m)

X mm
 Y mm
 $I_x \text{ cm}^4$
 $J_y \text{ cm}^4$



**M 9357
 385**

25,00
 60,00
 4,10
 0,63



**M 9356
 670**

25,00
 110,00
 28,12
 1,36



**M 9559
 608**

24,90
 84,60
 11,07
 1,08



**M 9534
 713**

24,90
 101,10
 20,73
 1,75



**M 9342
 466**

25,00
 100,00
 12,76
 0,99



**M 9348
 280**

25,00
 60,00
 0,56
 4,51

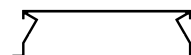

**M 9564
 604**

100,00
 25,00
 1,44
 26,19

**Προφίλ
Profiles
1:1**

M 15008

W=863 gr/m

ΚΑΣΑ ΙΣΙΑ ΜΙΚΡΗ
FRAME SMALL FLAT

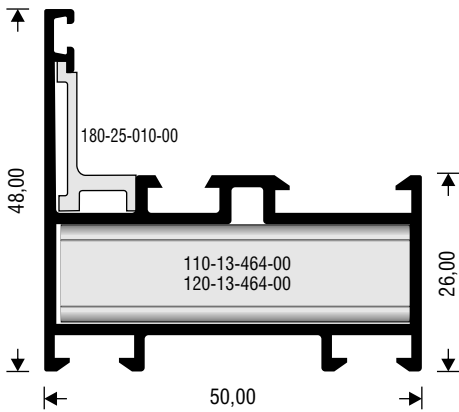

M 15210

W=1053 gr/m

ΚΑΣΑ ΙΣΙΑ ΜΕΣΑΙΑ
ΜΕ ΑΡΜΟΚΑΛΥΠΤΡΟ
FRAME FLAT MEDIUM
WITH ARMATURE

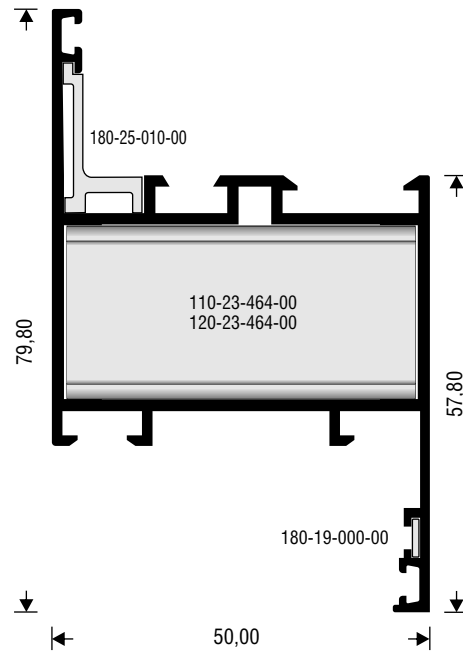

M 15010

W=951 gr/m

ΚΑΣΑ ΙΣΙΑ ΜΕΣΑΙΑ
FRAME MEDIUM FLAT

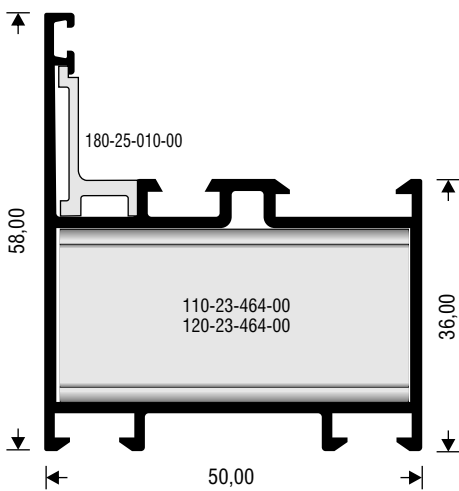

M 15014

W=989 gr/m

ΚΑΣΑ ΚΑΜΠΥΛΗ ΜΙΚΡΗ
FRAME ROUND SMALL

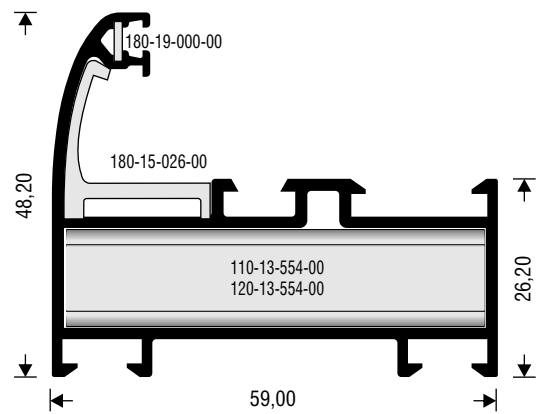

M 15012

W=1036 gr/m

ΚΑΣΑ ΙΣΙΑ ΜΕΓΑΛΗ
FRAME LARGE FLAT

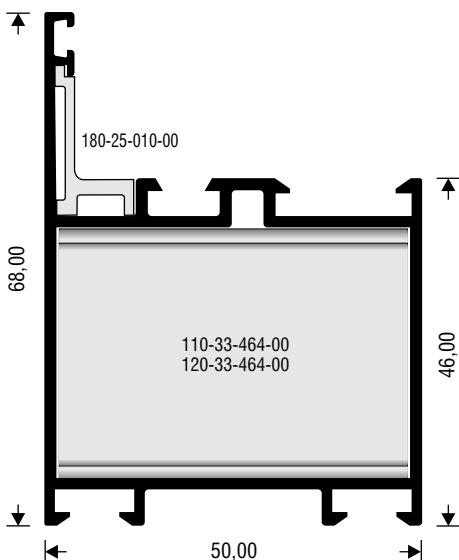

M 15016

W=1074 gr/m

ΚΑΣΑ ΚΑΜΠΥΛΗ
FRAME ROUND

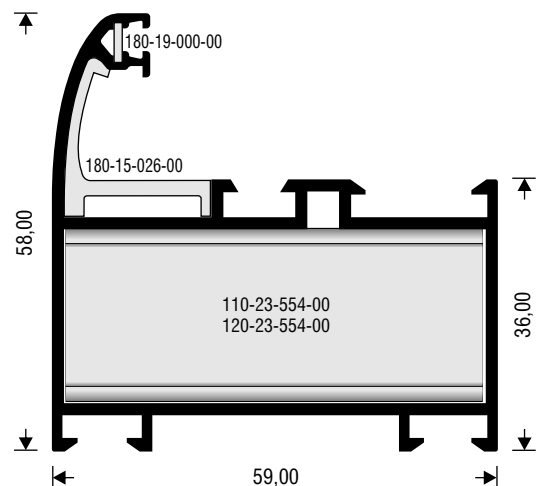

M 15018

W=1159 gr/m

ΚΑΣΑ ΚΑΜΠΥΛΗ ΜΕΓΑΛΗ
FRAME ROUND LARGE

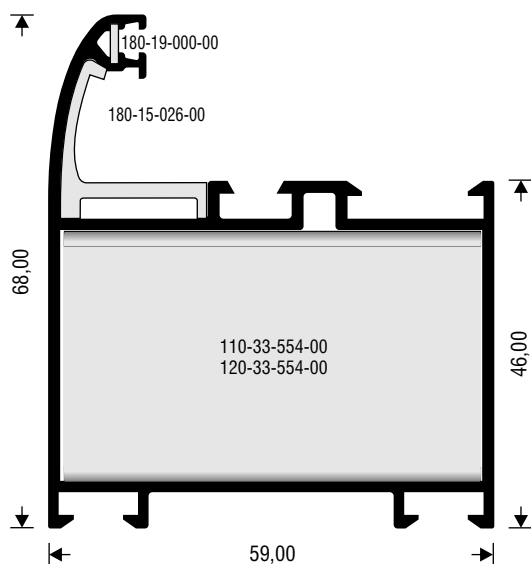

M 15013

W=1203 gr/m

ΚΑΣΑ ΜΕ ΑΡΜΟΚΑΛΥΠΤΡΟ
FRAME WITH ARMATURE

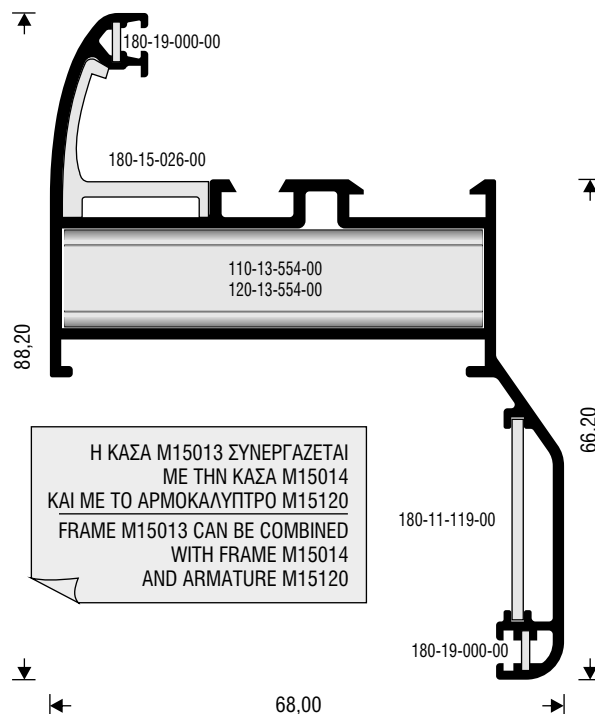

M 15022

W=1092 gr/m

ΚΑΣΑ "CLASSIC"
FRAME "CLASSIC"

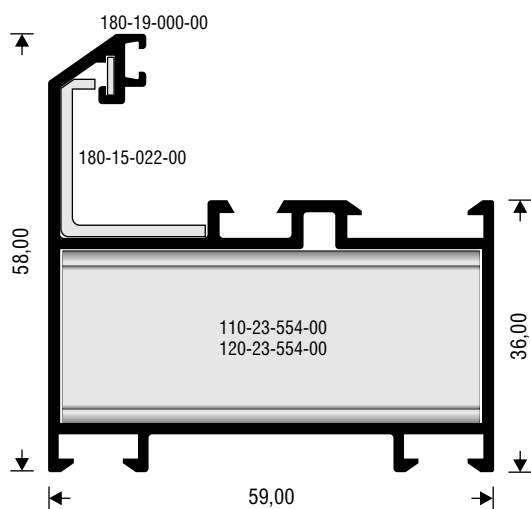

M 15024

W=1177 gr/m

ΚΑΣΑ "CLASSIC" ΜΕΓΑΛΗ
FRAME LARGE "CLASSIC"

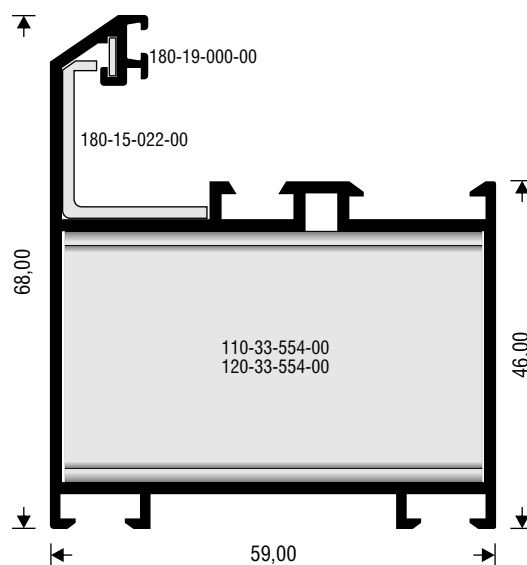

M 15025

W=1589 gr/m

ΚΑΣΑ - ΚΟΛΩΝΑ ΚΑΜΠΥΛΗ
FRAME / COLUMN ROUND

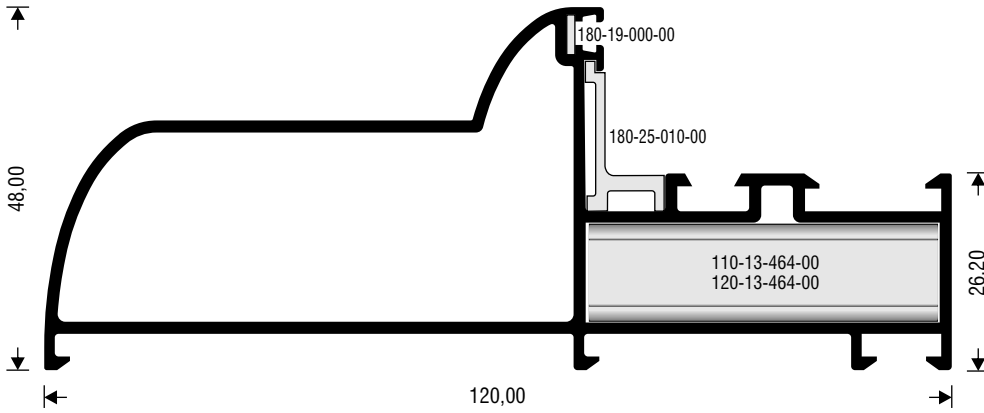

ΓΙΑ ΤΗ ΣΥΝΕΡΓΑΣΙΑ ΤΗΣ ΚΑΣΑΣ M15025
ΜΕ ΤΑ ΠΡΟΦΙΛ ΤΑΦ M15085 ΚΑΙ M15088
ΧΡΗΣΙΜΟΠΟΙΕΙΤΑΙ ΤΟ ΞΥΛΟΥΡΙΣΤΙΚΟ
ΚΩΔ.: 852-15-088-00

IN ORDER TO USE FRAME M15025
WITH "T" PROFILES M15085 AND M15088
YOU MUST OBTAIN MILLING BIT
CODE: 852-15-088-00

M 15027

W=1572 gr/m

ΚΑΣΑ - ΚΟΛΩΝΑ ΚΑΜΠΥΛΗ
FRAME / COLUMN ROUND

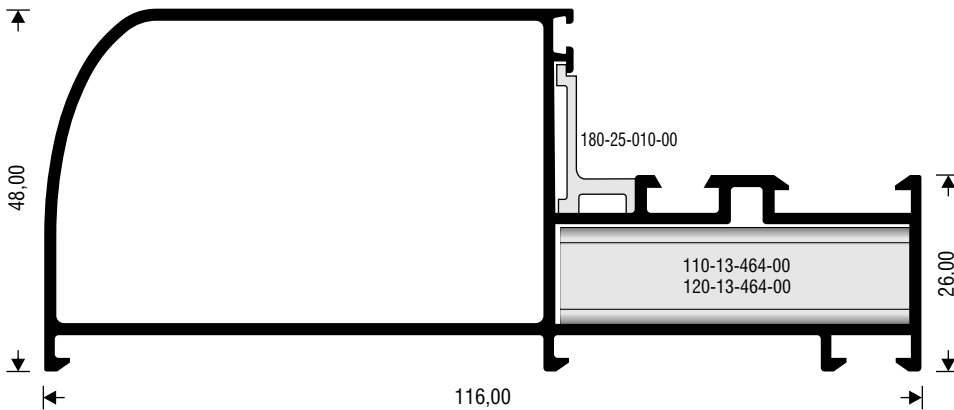

ΚΑΤΑΣΚΕΥΑΣΤΙΚΗ ΛΥΣΗ ΓΙΑ ΒΙΤΡΙΝΕΣ:
Η ΚΑΣΑ M15027 ΣΥΝΕΡΓΑΖΕΤΑΙ
ΜΕ ΤΑ ΠΡΟΦΙΛ M15085, M15088
ΓΙΑ ΤΗΝ ΚΑΤΑΣΚΕΥΗ ΒΙΤΡΙΝΩΝ

ΞΥΛΟΥΡΙΣΤΙΚΟ ΚΩΔ.: 852-15-026-00

SOLUTION FOR STORE FRONTS:
FRAME M15027 CAN BE USED
IN COMBINATION WITH PROFILES
M15085, M15088
TO FABRICATE STORE FRONTS

MILLING BIT CODE: 852-15-026-00

M 15026

W=1608 gr/m

ΚΑΣΑ - ΚΟΛΩΝΑ ΙΣΙΑ
FRAME / COLUMN FLAT

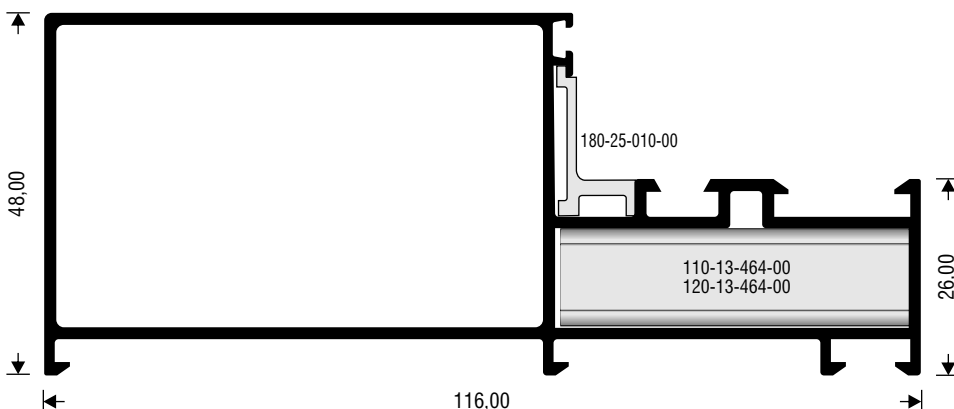

ΚΑΤΑΣΚΕΥΑΣΤΙΚΗ ΛΥΣΗ ΓΙΑ ΒΙΤΡΙΝΕΣ:
Η ΚΑΣΑ M15026 ΣΥΝΕΡΓΑΖΕΤΑΙ
ΜΕ ΤΑ ΠΡΟΦΙΛ M15083, M15084, M15082
ΓΙΑ ΤΗΝ ΚΑΤΑΣΚΕΥΗ ΒΙΤΡΙΝΩΝ

ΞΥΛΟΥΡΙΣΤΙΚΟ ΚΩΔ.: 852-15-026-00

SOLUTION FOR STORE FRONTS:
FRAME M15026 CAN BE USED
IN COMBINATION WITH PROFILES
M15083, M15084, M15082
TO FABRICATE STORE FRONTS

MILLING BIT CODE: 852-15-026-00

M 15080

W=1543 gr/m

ΚΑΣΑ - ΑΡΜΟΥ ΔΙΑΣΤΟΛΗΣ
"T" PROFILE LARGE EXPANSION JOINT

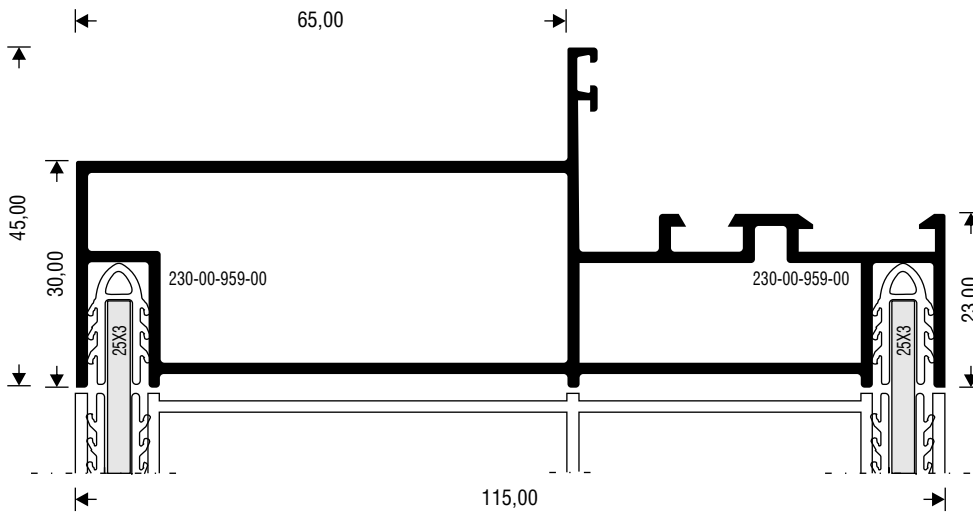

ΓΙΑ ΤΗ ΣΥΝΕΡΓΑΣΙΑ ΤΗΣ ΚΑΣΑΣ M15080 ΜΕ ΤΑ ΠΡΟΦΙΛ ΤΑΦ M15082, M15083 ΚΑΙ M15084 ΧΡΗΣΙΜΟΠΟΙΕΙΤΑΙ ΤΟ ΞΥΛΟΥΡΙΣΤΙΚΟ ΚΩΔ.: 852-15-083-00

FOR THE COMBINED USE OF FRAME M15080 WITH "T" PROFILES M15082, M15083 AND M15084 PLEASE USE MILLING BIT CODE: 852-15-083-00

M 15150

W=2274 gr/m

ΕΝΙΑΙΑ ΚΑΣΑ
LARGE FRAME FOR WINDOWS WITH SHUTTERS

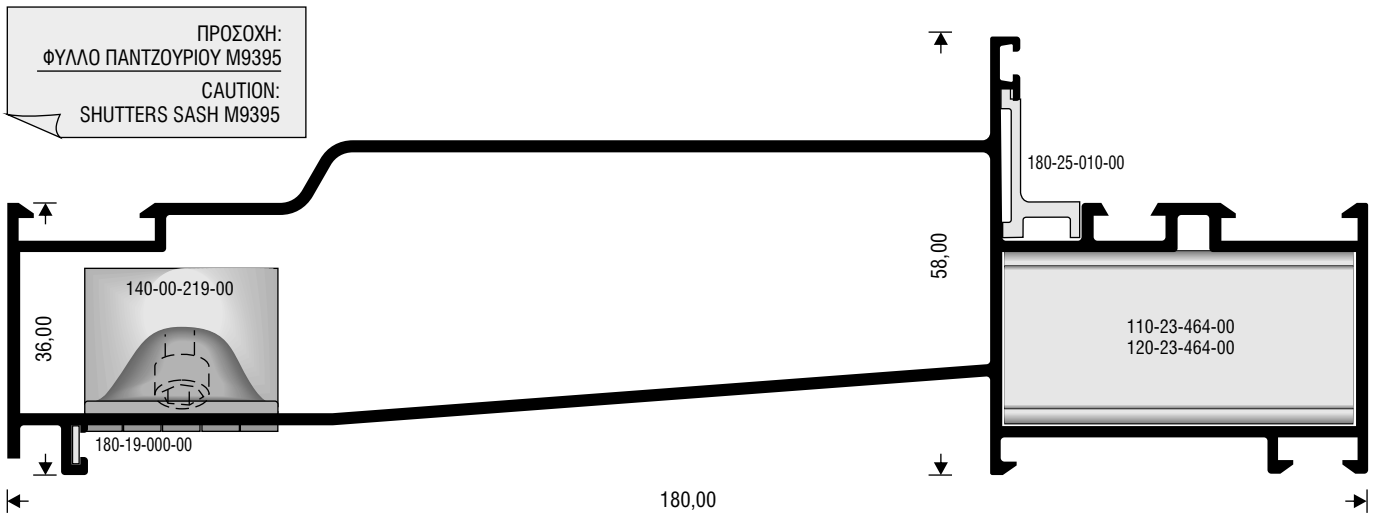

ΠΡΟΣΟΧΗ:
ΦΥΛΛΟ ΠΑΝΤΖΟΥΡΙΟΥ M9395
CAUTION:
SHUTTERS SASH M9395

M 15461

W=1581 gr/m

ΚΑΣΑ ΔΙΑΙΡΟΥΜΕΝΗ
TWO-PIECE FRAME

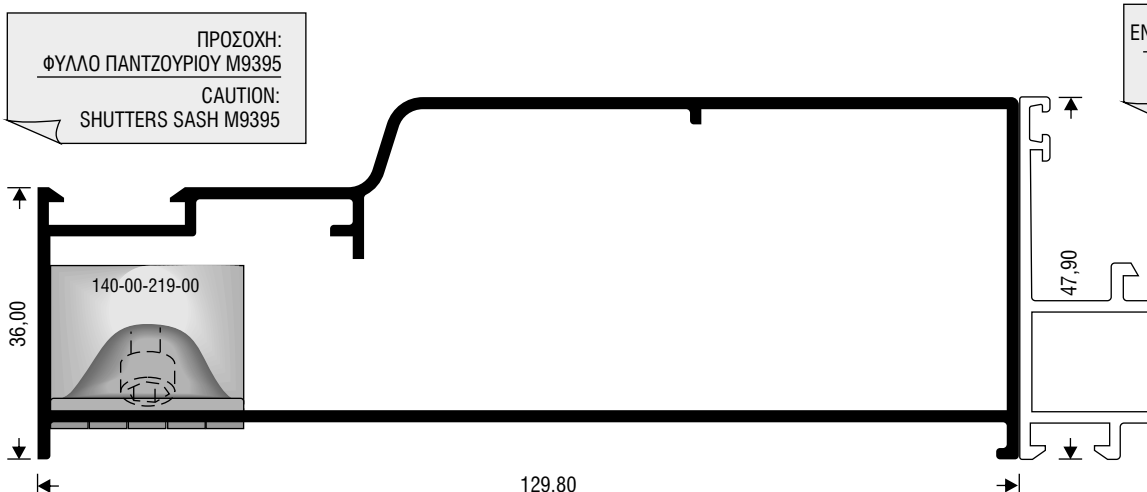

ΠΡΟΣΟΧΗ:
ΦΥΛΛΟ ΠΑΝΤΖΟΥΡΙΟΥ M9395
CAUTION:
SHUTTERS SASH M9395

ΕΝΔΕΙΚΝΥΤΑΙ ΓΙΑ ΔΙΧΡΟΜΙΕΣ
IDEAL FOR
TWO-COLOUR FRAMES

M 15205

W=1147 gr/m

ΚΑΣΑ ΔΙΑΙΡΟΥΜΕΝΗ
TWO - PIECE FRAME

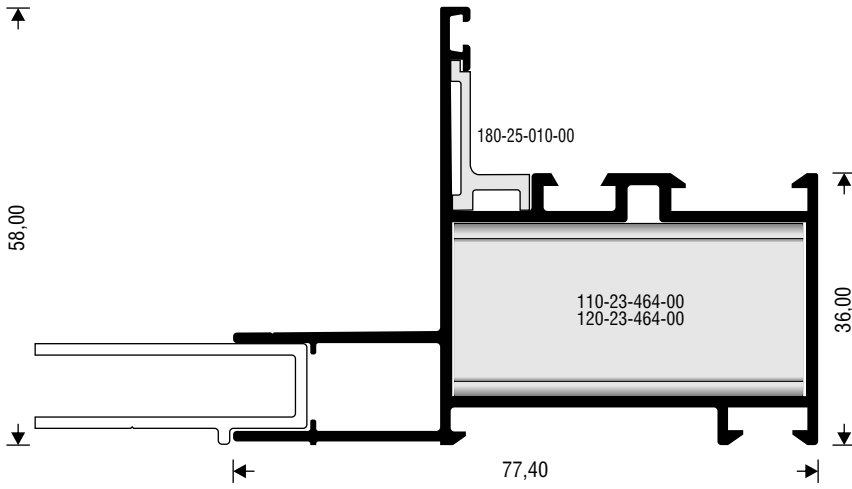

M 9379

W=1446 gr/m

ΚΑΣΑ ΔΙΑΙΡΟΥΜΕΝΗ
TWO - PIECE FRAME

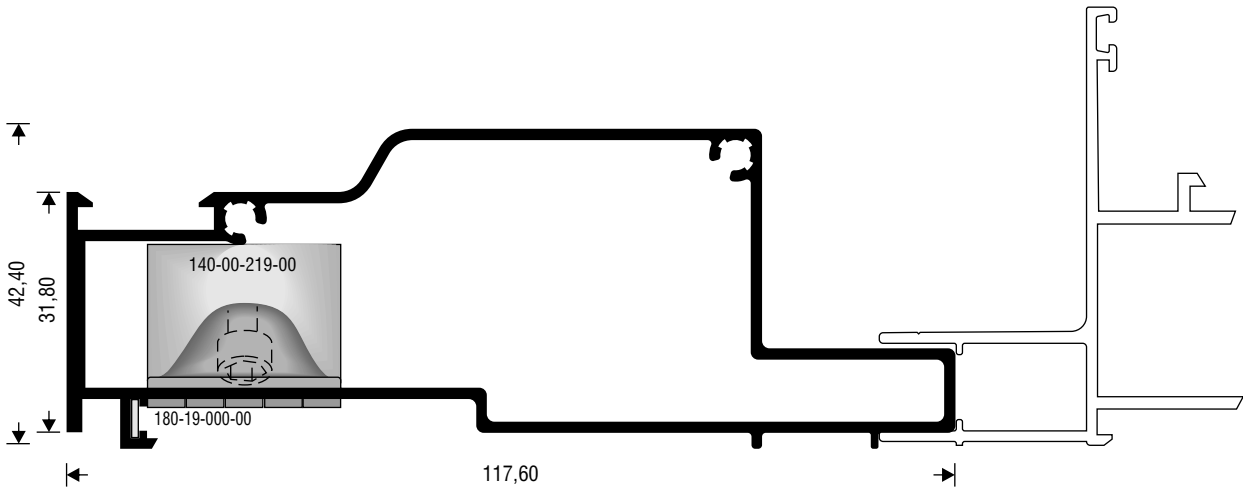

M 9381

W=1036 gr/m

ΚΑΤΩΚΑΣΙ
THRESHOLD

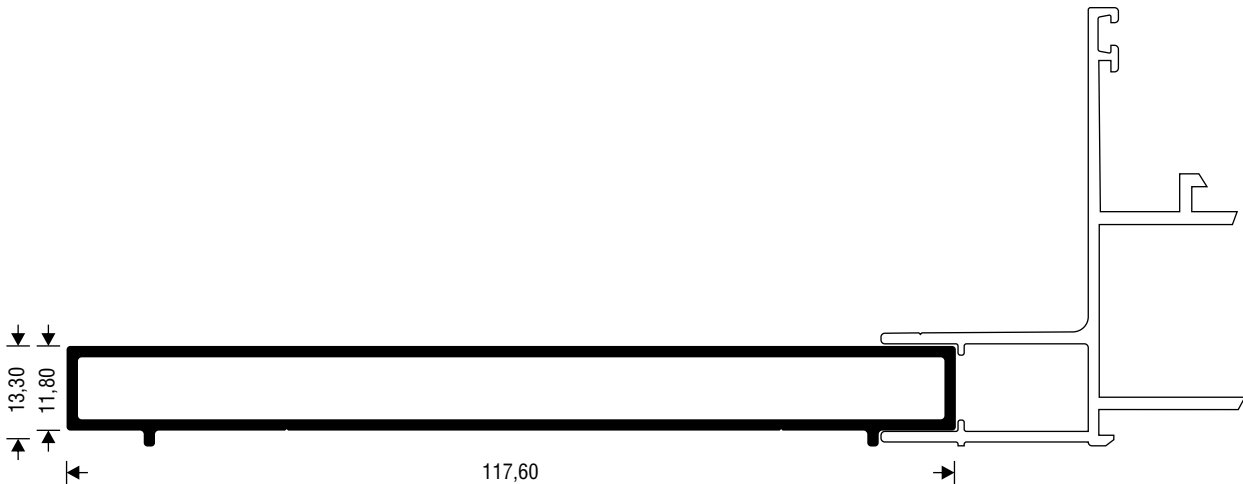

M 15030

W=1075 gr/m

ΦΥΛΛΟ ΙΣΙΟ ΜΙΚΡΟ
SASH SMALL FLAT

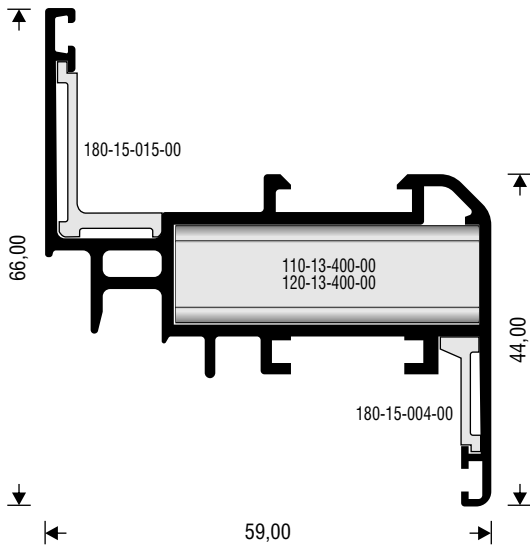

M 15032

W=1220 gr/m

ΦΥΛΛΟ ΙΣΙΟ ΜΕΣΑΙΟ
SASH MEDIUM FLAT

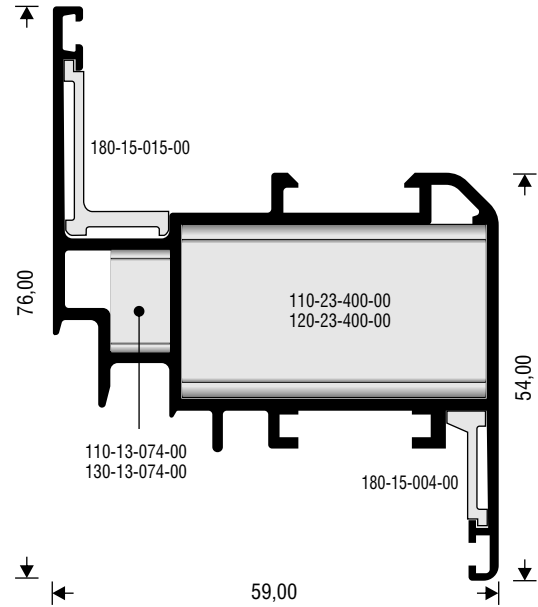

M 15036

W=1469 gr/m

ΦΥΛΛΟ ΒΟΗΘΗΤΙΚΗΣ ΕΙΣΟΔΟΥ
SASH MEDIUM, FOR MAIL ENTRANCES

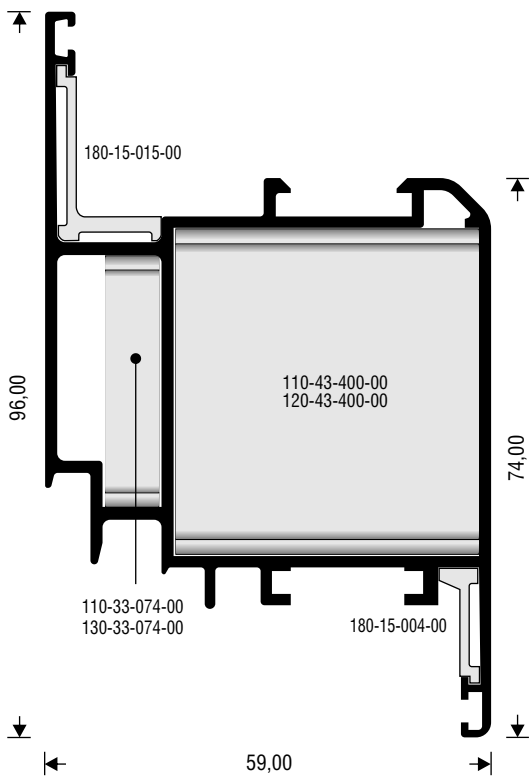

M 15034

W=1650 gr/m

ΦΥΛΛΟ ΙΣΙΟ ΜΕΓΑΛΟ
SASH LARGE FLAT

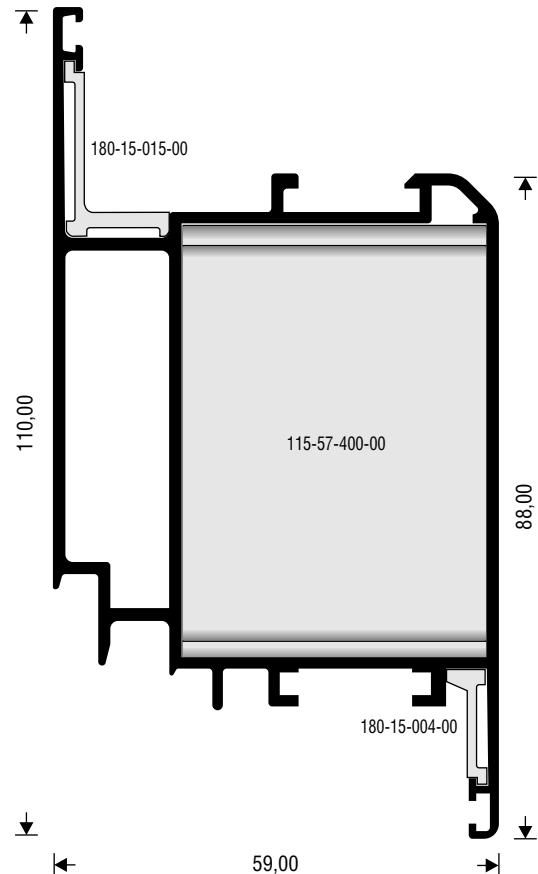

M 15031

W=1046 gr/m

ΦΥΛΛΟ ΙΣΙΟ ΜΙΚΡΟ
SASH SMALL FLAT

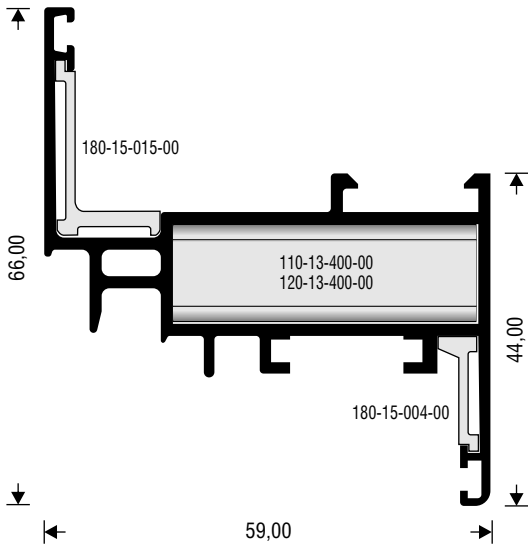

M 15033

W=1204 gr/m

ΦΥΛΛΟ ΙΣΙΟ ΜΕΣΑΙΟ
SASH MEDIUM FLAT

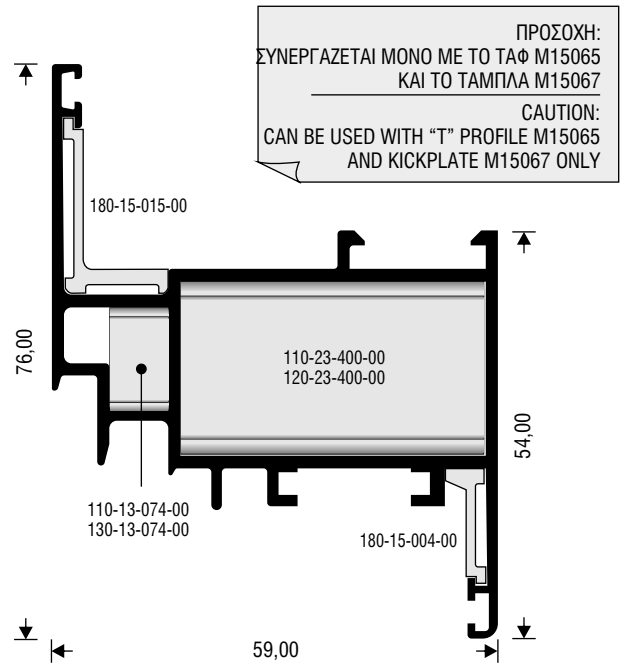

M 15035

W=1629 gr/m

ΦΥΛΛΟ ΙΣΙΟ ΜΕΓΑΛΟ
SASH LARGE FLAT

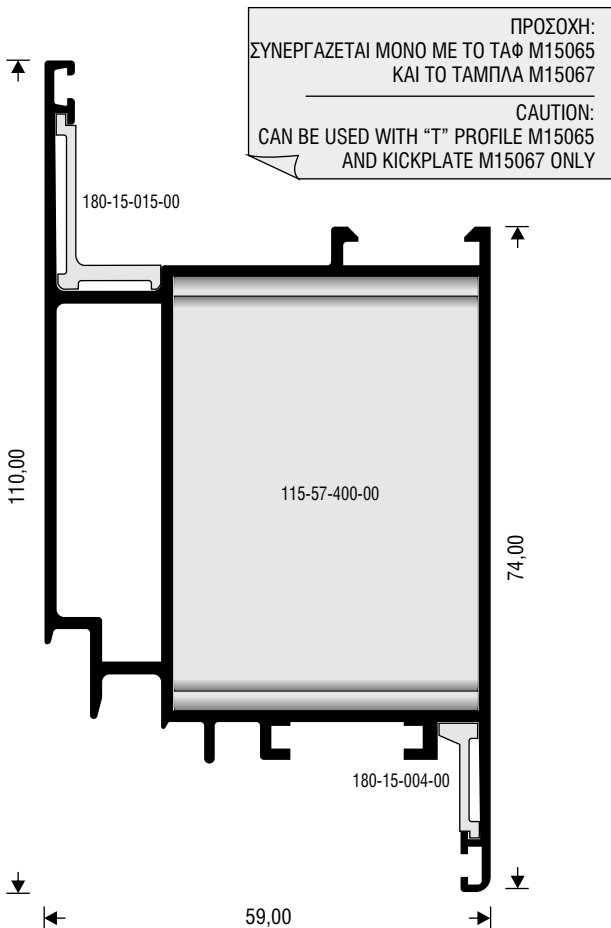

M 15040

W=1099 gr/m

ΦΥΛΛΟ ΚΑΜΠΥΛΟ ΜΙΚΡΟ
SASH SMALL ROUND

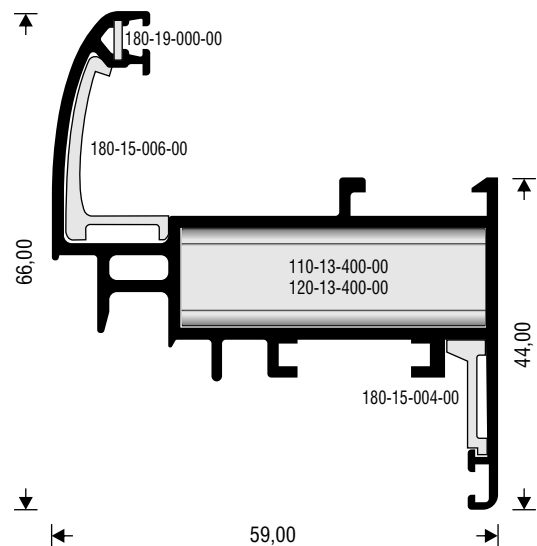

M 15042

W=1261 gr/m

ΦΥΛΛΟ ΚΑΜΠΥΛΟ ΜΕΣΑΙΟ
SASH MEDIUM ROUND

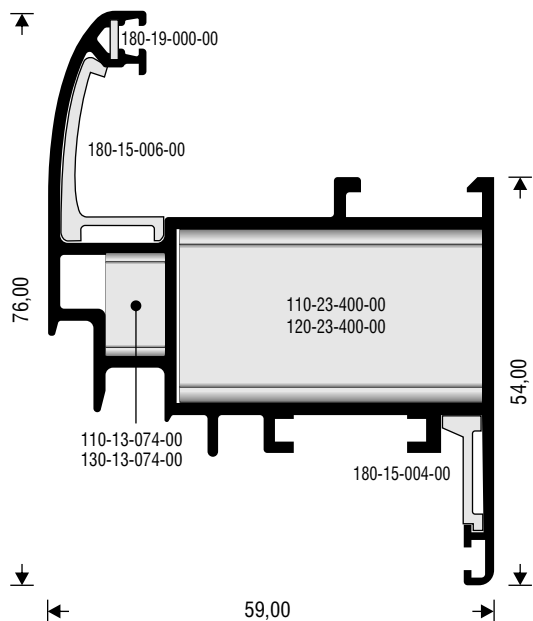

M 15046

W=1207 gr/m

ΦΥΛΛΟ ΜΕ ΕΝΣΩΜΑΤΩΜΕΝΟ ΠΗΧΑΚΙ
SMALL ROUND SASH WITH BEAD
FOR DOUBLE GLAZING

ΧΩΡΙΣΜΑ / "H" PROFILE: M9391

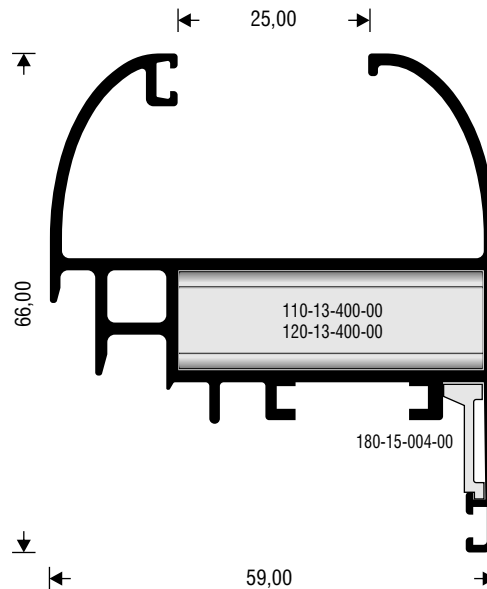

M 15044

W=1697 gr/m

ΦΥΛΛΟ ΚΑΜΠΥΛΟ ΜΕΓΑΛΟ
SASH LARGE ROUND

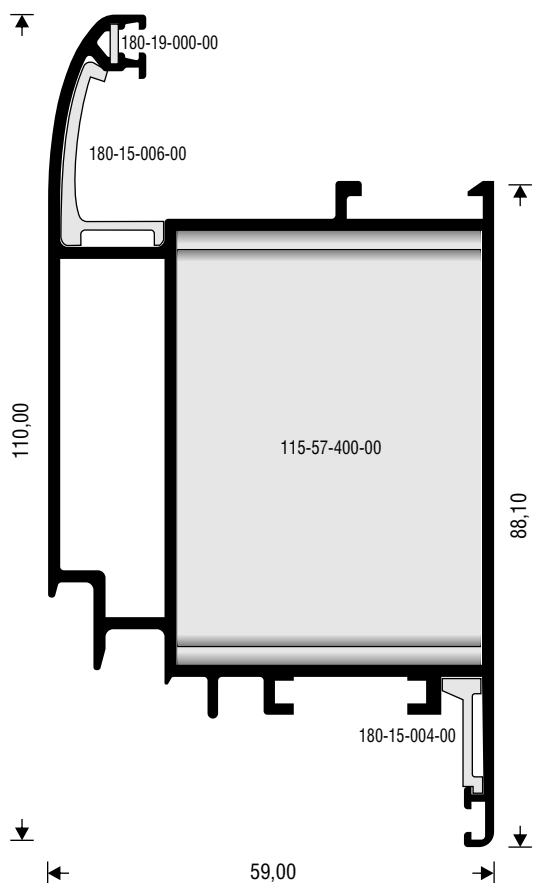

M 15050

W=1115 gr/m

ΦΥΛΛΟ ΜΙΚΡΟ
SASH SMALL

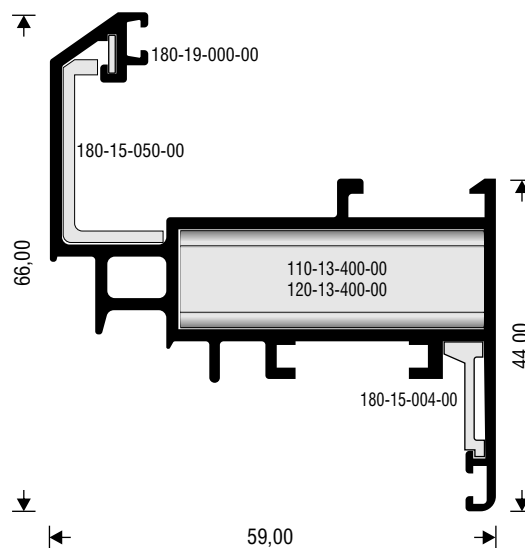

M 15052
W=1280 gr/m

ΦΥΛΛΟ ΜΕΣΑΙΟ
SASH MEDIUM

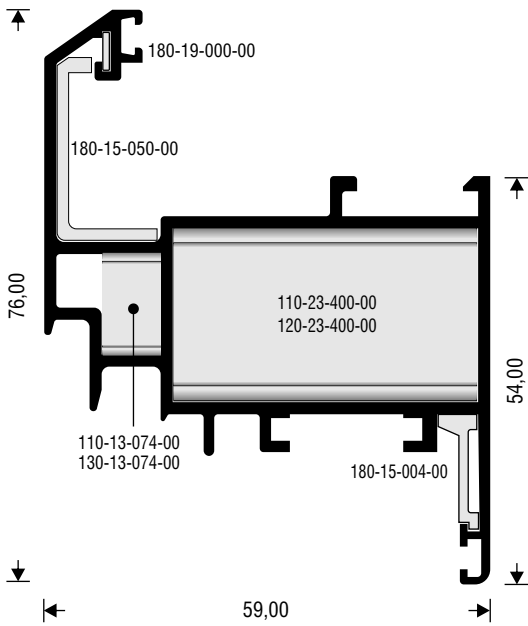

M 15250
W=1221 gr/m

ΦΥΛΛΟ ΜΕΣΑΙΟ
SASH MEDIUM

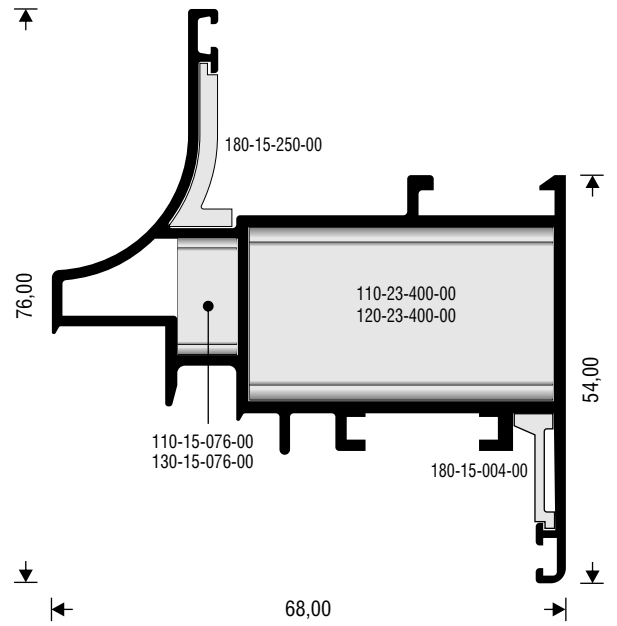

M 15054
W=1699 gr/m

ΦΥΛΛΟ ΜΕΓΑΛΟ
SASH LARGE

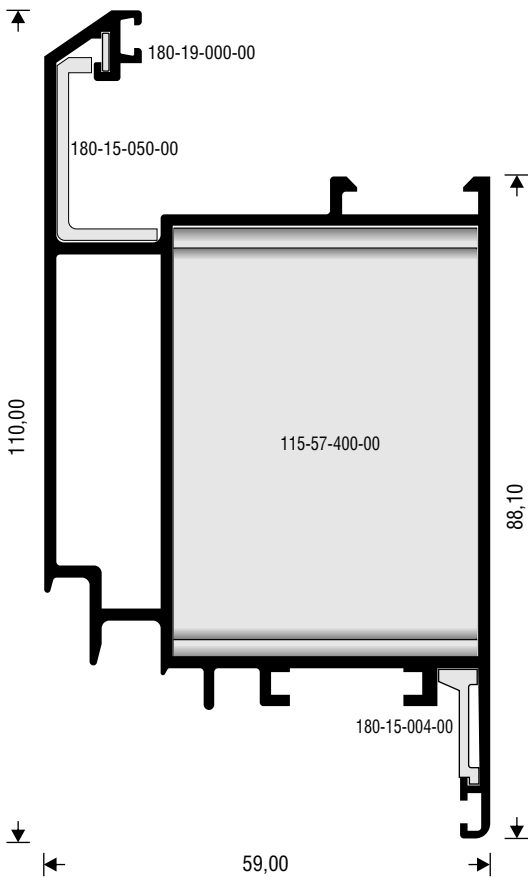

M 15324
W=1821 gr/m

ΦΥΛΛΟ ΜΕΓΑΛΟ
SASH LARGE

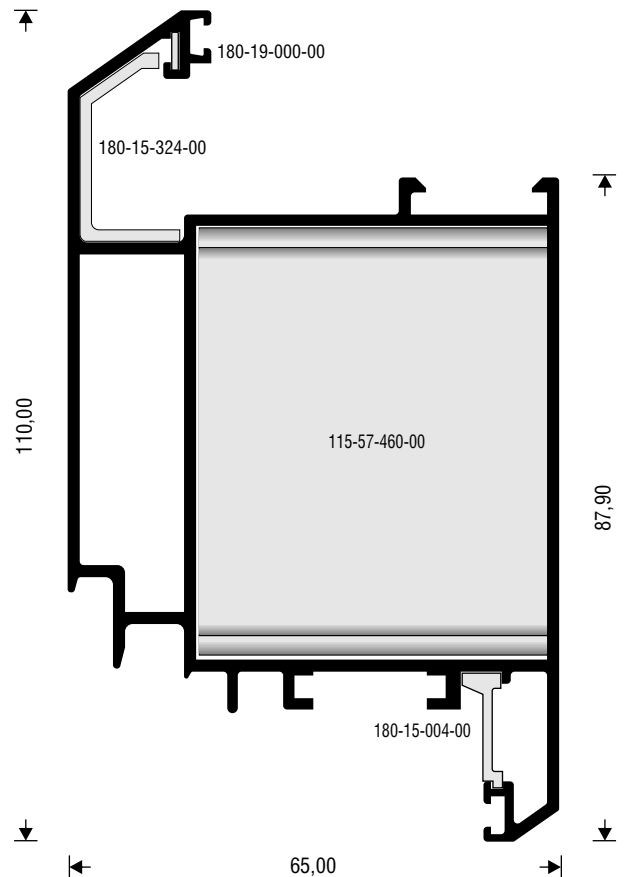

M 15181

W=1240 gr/m

ΣΥΜΠΛΗΡΩΜΑ ΦΥΛΛΟΥ ΕΙΣΟΔΟΥ
ENTRANCE SASH EXTENSION
(KICKPLATE EFFECT)

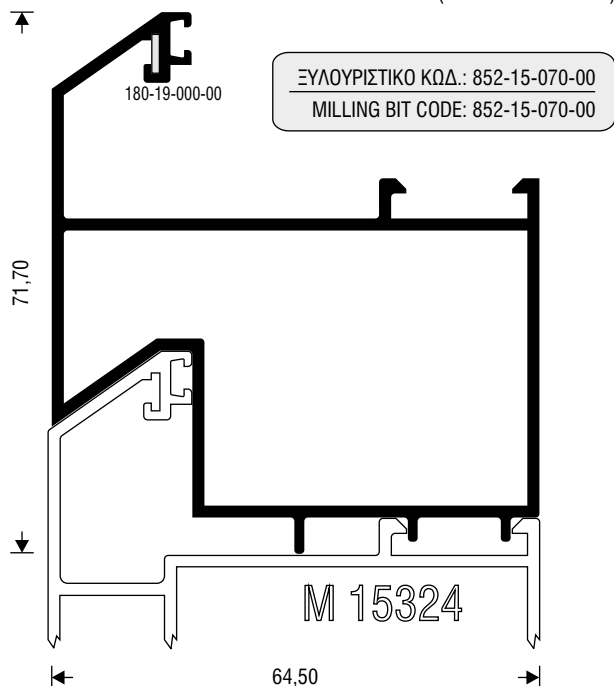

M 15393

W=1416 gr/m

ΦΥΛΛΟ ΑΝΟΙΓΟΜΕΝΟ ΠΡΟΣ ΤΑ ΕΞΩ
SASH OPENING OUTWARDS

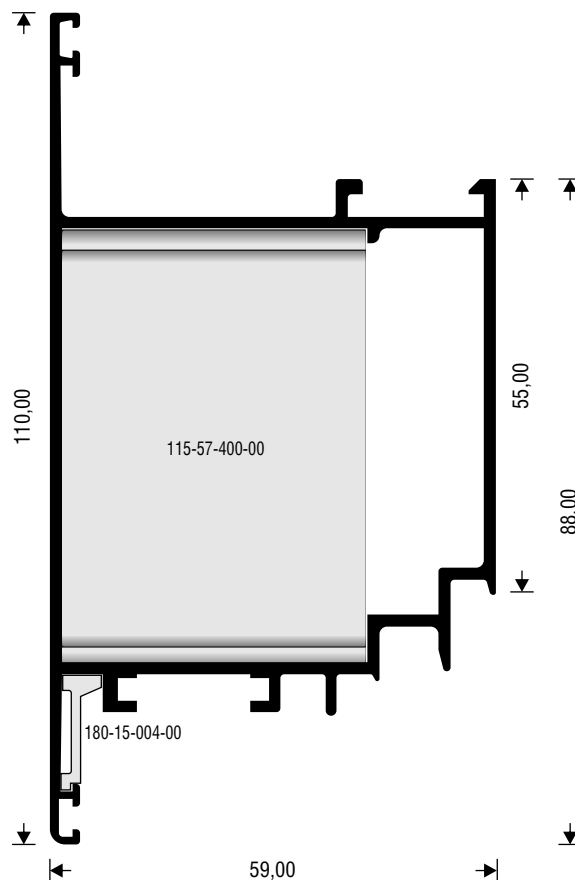

M 15190

W=1463 gr/m

ΦΥΛΛΟ ΑΝΟΙΓΟΜΕΝΟ ΠΡΟΣ ΤΑ ΕΞΩ
SASH OPENING OUTWARDS

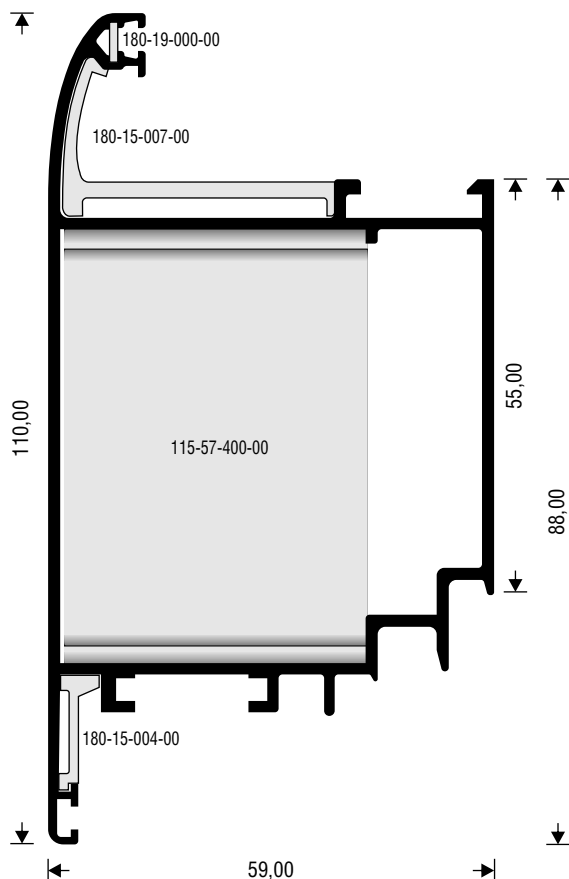

M 15460

W=1196 gr/m

ΦΥΛΛΟ ΑΝΟΙΓΟΜΕΝΟ ΠΡΟΣ ΤΑ ΕΞΩ
SASH OPENING OUTWARDS

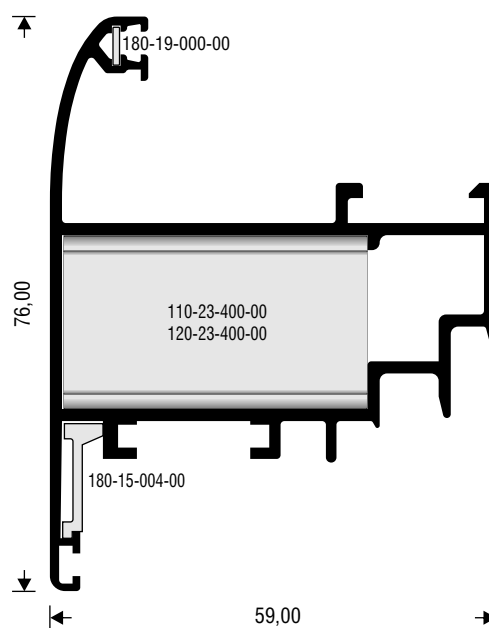

ΓΙΑ ΝΕΟΥ ΤΥΠΟΥ ΠΡΕΣΑΡΙΣΤΕΣ ΓΩΝΙΕΣ ΣΥΝΔΕΣΗΣ, ΑΝΤΙΚΑΤΑΣΤΗΣΤΕ ΤΟΝ ΚΩΔΙΚΟ 110-**-***-00 ΜΕ 115-**-***-00.
ΓΙΑ ΝΕΟΥ ΤΥΠΟΥ ΒΙΔΩΤΕΣ ΓΩΝΙΕΣ ΣΥΝΔΕΣΗΣ, ΑΝΤΙΚΑΤΑΣΤΗΣΤΕ ΤΟΝ ΚΩΔΙΚΟ 120-**-***-00 ΜΕ 125-**-***-00.
ΓΙΑ ΝΕΟΥ ΤΥΠΟΥ ΠΡΕΣΑΡΙΣΤΕΣ ΓΩΝΙΕΣ ΣΥΝΔΕΣΗΣ, ΑΝΤΙΚΑΤΑΣΤΗΣΤΕ ΤΟΝ ΚΩΔΙΚΟ 110-**-***-00 ΜΕ 115-**-***-00.
ΓΙΑ ΝΕΟΥ ΤΥΠΟΥ ΒΙΔΩΤΕΣ ΓΩΝΙΕΣ ΣΥΝΔΕΣΗΣ, ΑΝΤΙΚΑΤΑΣΤΗΣΤΕ ΤΟΝ ΚΩΔΙΚΟ 120-**-***-00 ΜΕ 125-**-***-00.

M 15004

W=1111 gr/m

ΜΠΙΝΙ ΙΣΙΟ
MEETING STILE

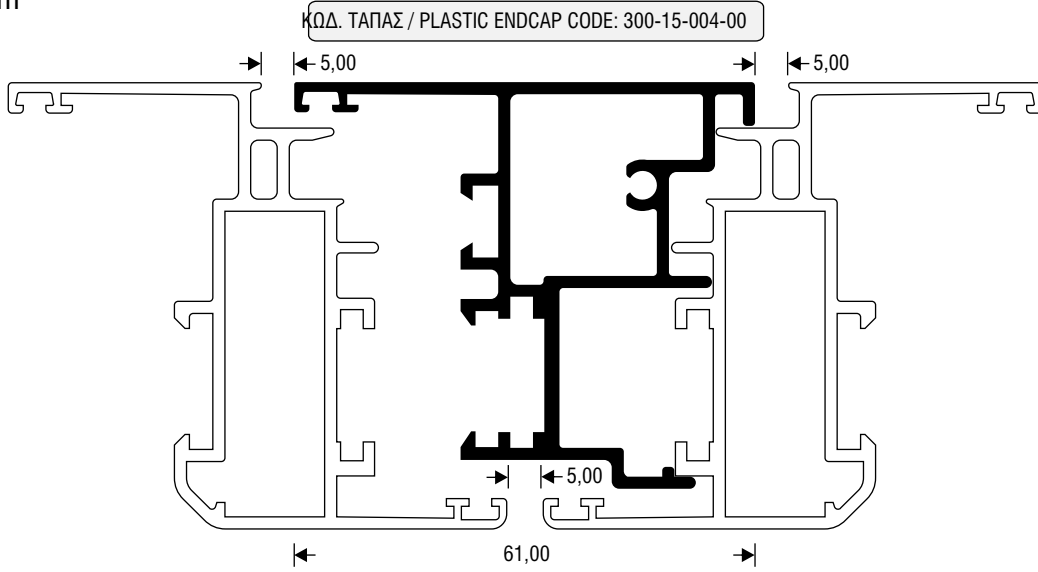

M 15005

W=1293 gr/m

ΜΠΙΝΙ
MEETING STILE

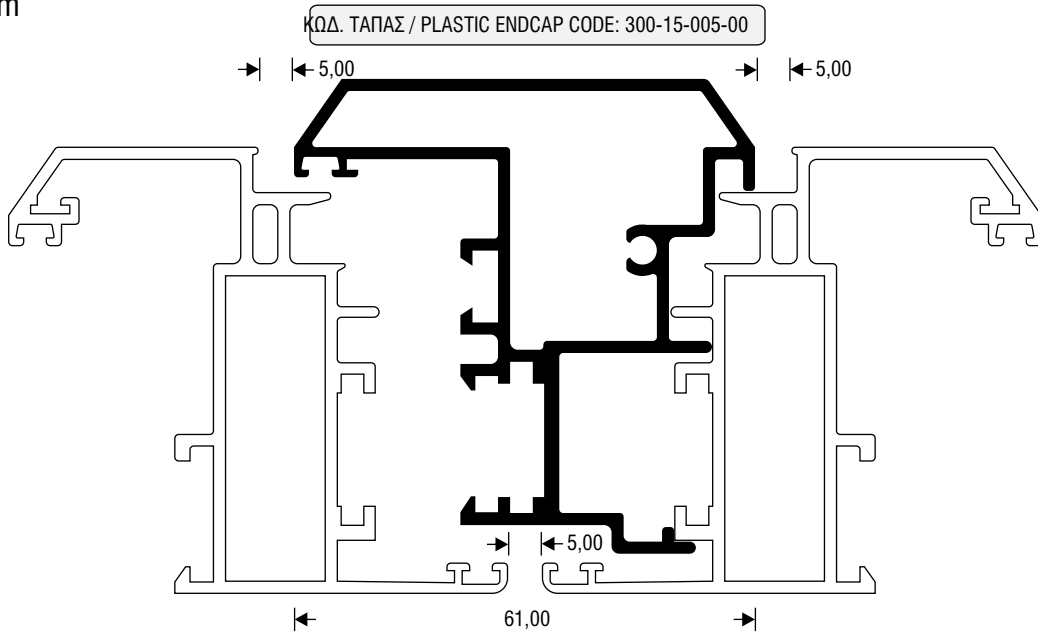

M 15006

W=1210 gr/m

ΜΠΙΝΙ ΚΑΜΠΥΛΟ
MEETING STILE

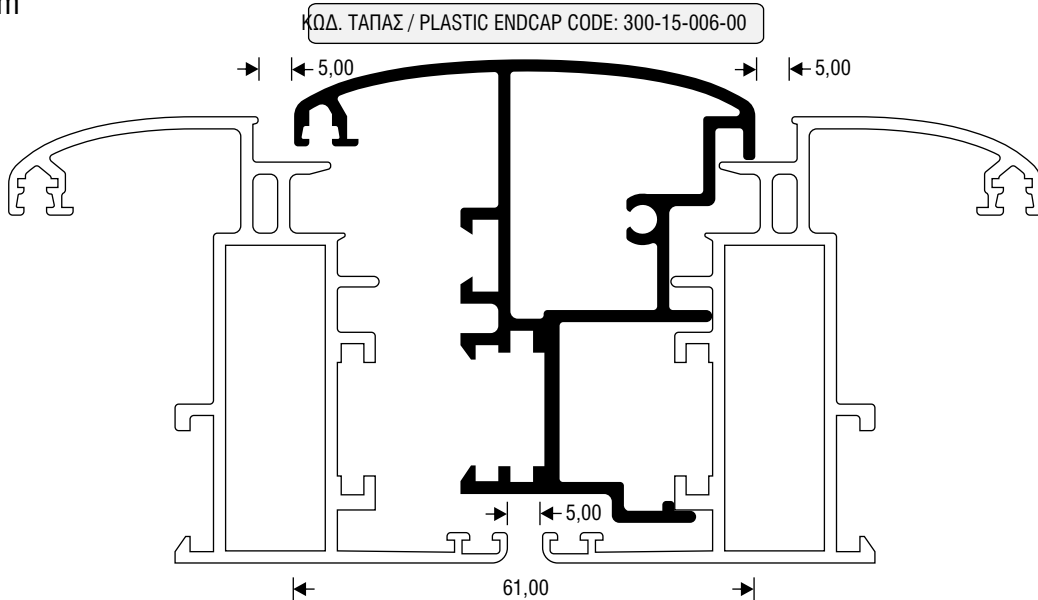

M 15060
W=979 gr/m

“ΤΑΦ” ΜΙΚΡΟ
TRANSOM

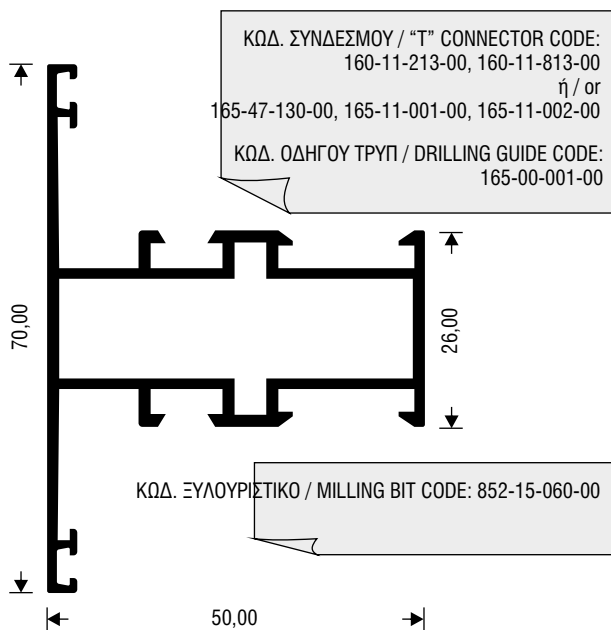

M 15062
W=1067 gr/m

“ΤΑΦ” ΜΕΣΑΙΟ
MULLION

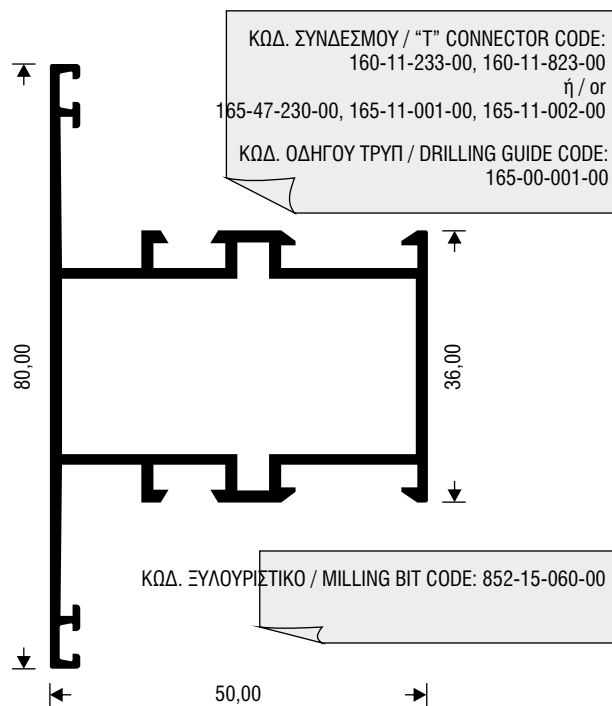

M 15064
W=1154 gr/m

“ΤΑΦ” ΜΕΣΑΙΟ
MULLION

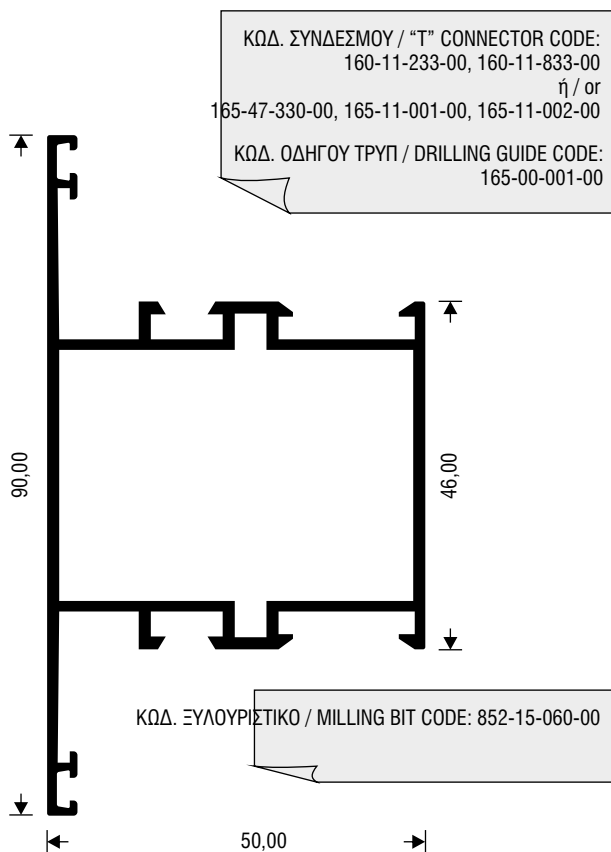

M 15066
W=1239 gr/m

“ΤΑΦ”
MULLION

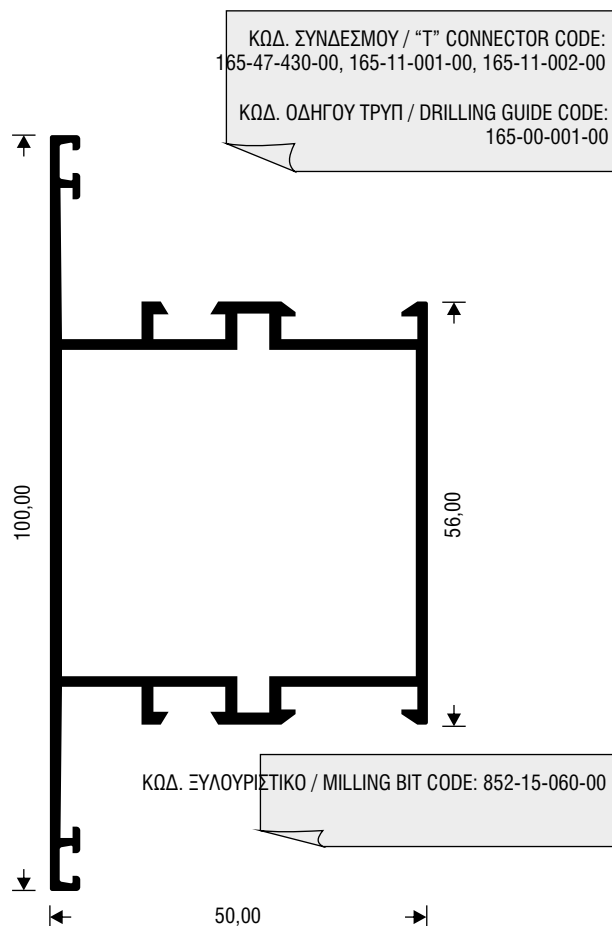

M 15266

W=1262 gr/m

"ΤΑΦ" ΜΕΣΑΙΟ
MULLION

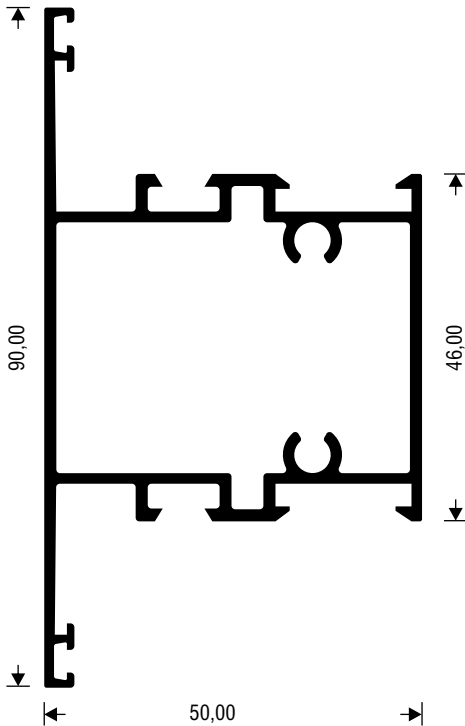

ΚΩΔ. ΞΥΛΟΥΡΙΣΤΙΚΟ / MILLING BIT CODE: 852-15-060-00

M 15068

W=1671 gr/m

"ΤΑΦ" ΜΕΓΑΛΟ
MULLION

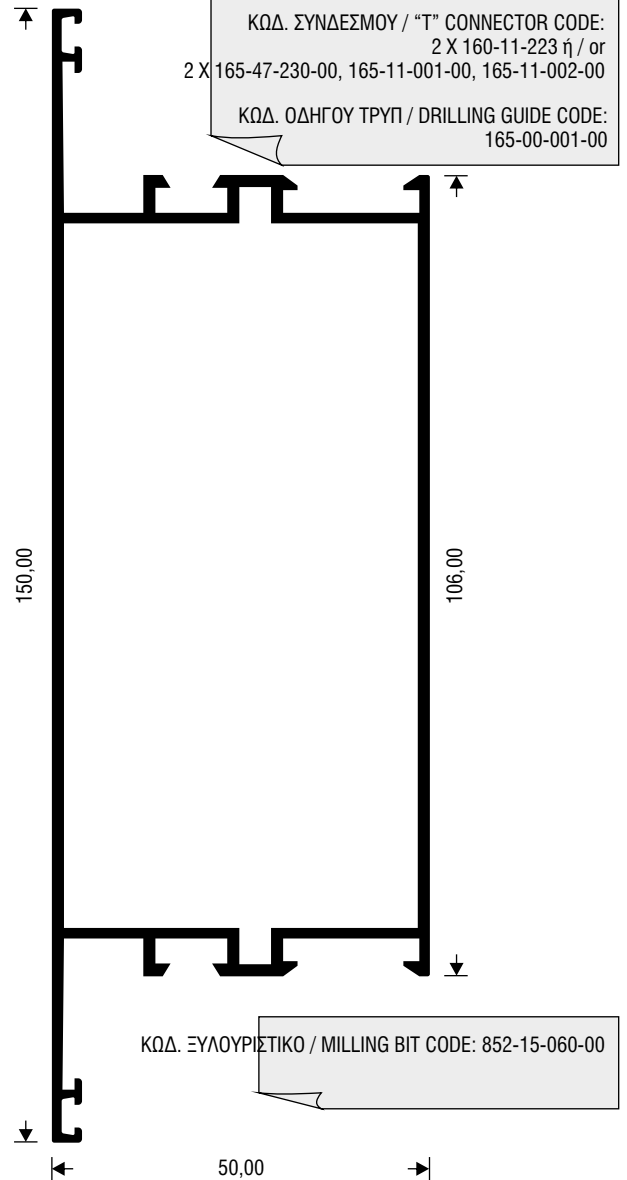

ΚΩΔ. ΞΥΛΟΥΡΙΣΤΙΚΟ / MILLING BIT CODE: 852-15-060-00

M 15071

W=943 gr/m

"ΤΑΦ" ΜΙΚΡΟ "CLASSIC"
MULLION

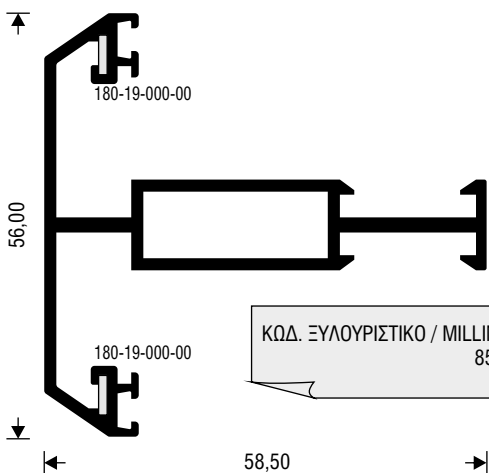

ΚΩΔ. ΞΥΛΟΥΡΙΣΤΙΚΟ / MILLING BIT CODE:
852-15-070-00

M 15070

W=1189 gr/m

"ΤΑΦ" - "CLASSIC"
MULLION

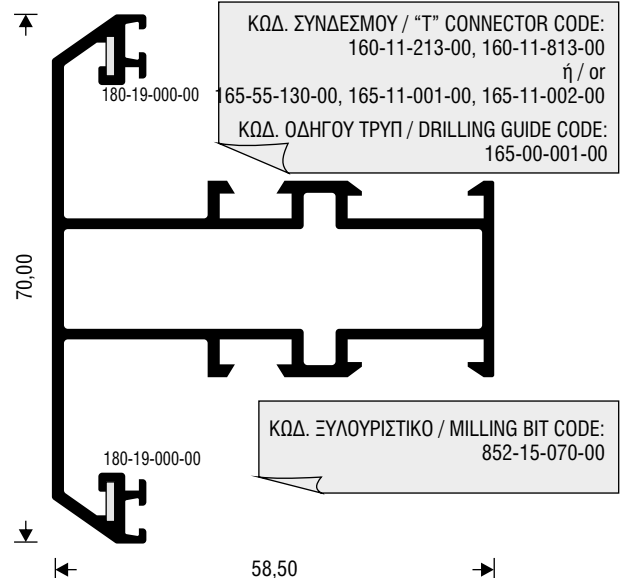

ΚΩΔ. ΣΥΝΔΕΣΜΟΥ / "T" CONNECTOR CODE:
160-11-213-00, 160-11-813-00
ή / or
165-55-130-00, 165-11-001-00, 165-11-002-00

ΚΩΔ. ΟΔΗΓΟΥ ΤΡΥΠ / DRILLING GUIDE CODE:
165-00-001-00

ΚΩΔ. ΞΥΛΟΥΡΙΣΤΙΚΟ / MILLING BIT CODE:
852-15-070-00

M 15074

W=1353 gr/m

"ΤΑΦ" ΜΕΓΑΛΟ "CLASSIC"
MULLION

ΚΩΔ. ΣΥΝΔΕΣΜΟΥ / "T" CONNECTOR CODE:
160-11-233-00, 160-11-833-00
ή / or
165-55-330-00, 165-11-001-00, 165-11-002-00
ΚΩΔ. ΟΔΗΓΟΥ ΤΡΥΠ / DRILLING GUIDE CODE:
165-00-001-00

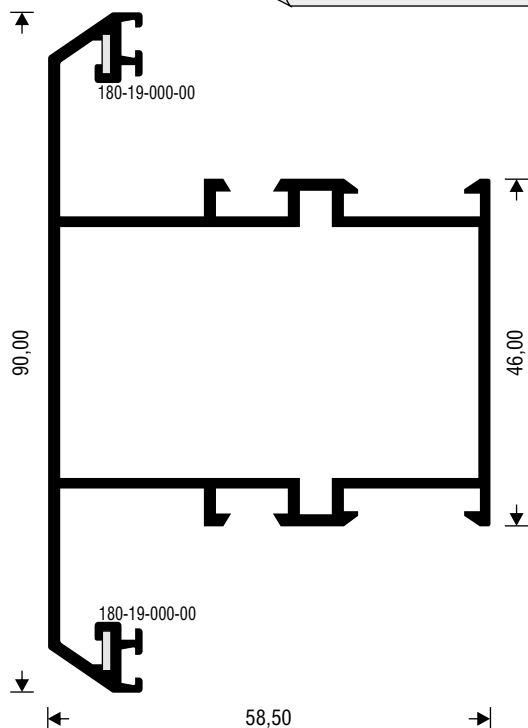

ΚΩΔ. ΞΥΛΟΥΡΙΣΤΙΚΟ / MILLING BIT CODE:
852-15-070-00

M 15065

W=1044 gr/m

"ΤΑΦ" ΜΕΣΑΙΟ - 59 mm
"T" PROFILE MEDIUM - 59 mm

ΚΩΔ. ΣΥΝΔΕΣΜΟΥ / "T" CONNECTOR CODE:
160-11-213-00, 160-11-813-00,
ή / or
165-55-130-00, 165-11-001-00, 165-11-002-00
ΚΩΔ. ΟΔΗΓΟΥ ΤΡΥΠ / DRILLING GUIDE CODE:
165-00-001-00

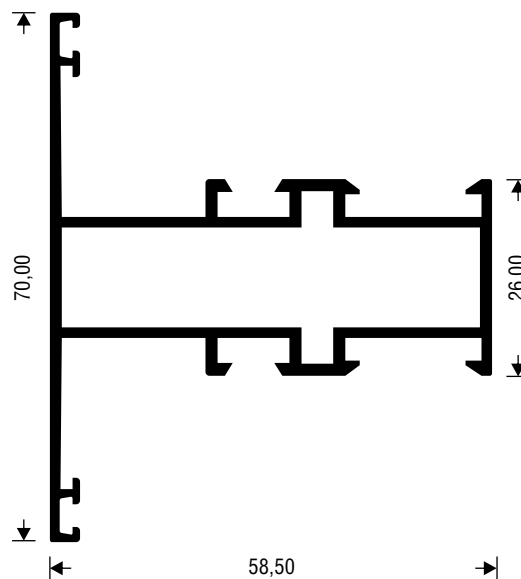

ΚΩΔ. ΞΥΛΟΥΡΙΣΤΙΚΟ / MILLING BIT CODE: 852-15-060-00

ΠΡΟΣΟΧΗ:
ΣΥΝΕΡΓΑΖΕΤΑΙ ΜΟΝΟ ΜΕ ΤΑ ΦΥΛΛΑ
M15031, M15033, M15035, M15393
CAUTION:
USED WITH SASHES
M15031, M15033, M15035 AND M15393 ONLY

M 15083

W=1676 gr/m

“ΤΑΦ” ΜΕΣΑΙΟ
MULLIONS FOR STORE FRONTS

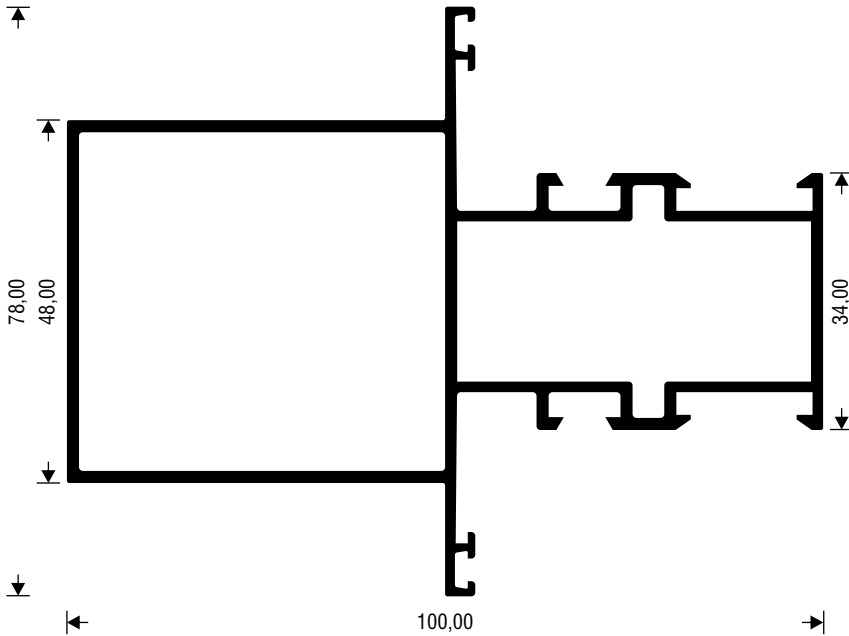

ΚΩΔ. ΣΥΝΔΕΣΜΟΥ / "T" CONNECTOR CODE:
160-11-221-00, 160-11-821-00
ή / or
165-47-130-00, 165-11-001-00, 165-11-002-00
ΚΩΔ. ΟΔΗΓΟΥ ΤΡΥΠ / DRILLING GUIDE CODE:
165-00-001-00

ΚΩΔ. ΞΥΛΟΥΡΙΣΤΙΚΟ / MILLING BIT CODE:
852-15-083-00

M 15084

W=1832 gr/m

ΚΟΛΩΝΑ “ΤΑΦ” ΙΣΙΑ
MULLIONS FOR STORE FRONTS

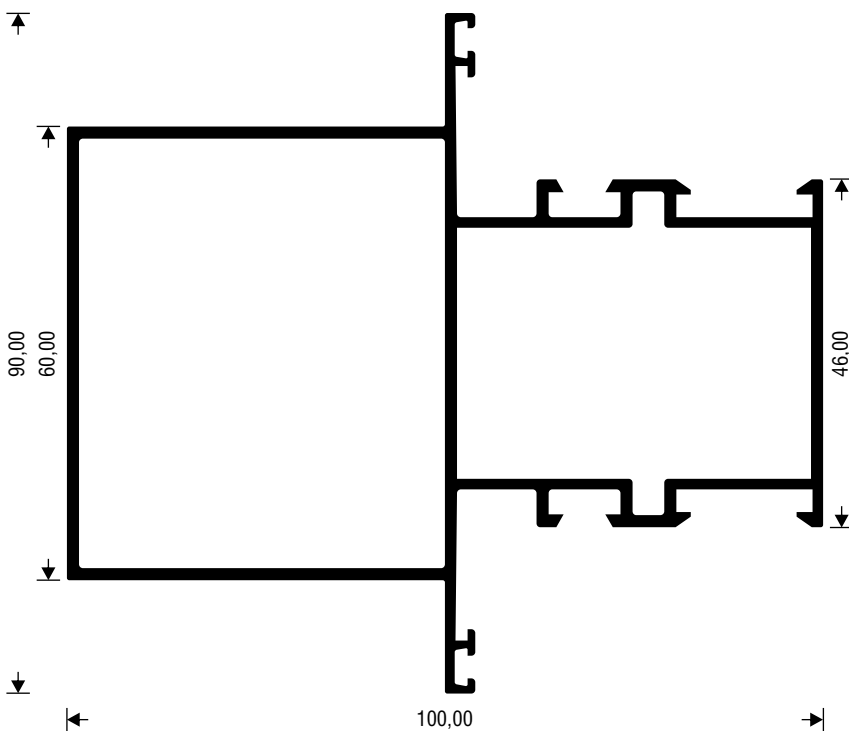

ΚΩΔ. ΣΥΝΔΕΣΜΟΥ / "T" CONNECTOR CODE:
160-11-233-00, 160-11-833-00
ή / or
165-47-330-00, 165-11-001-00, 165-11-002-00
ΚΩΔ. ΟΔΗΓΟΥ ΤΡΥΠ / DRILLING GUIDE CODE:
165-00-001-00

ΚΩΔ. ΞΥΛΟΥΡΙΣΤΙΚΟ / MILLING BIT CODE:
852-15-083-00

M 15082

W=1962 gr/m

ΚΟΛΩΝΑ "ΤΑΦ" ΙΣΙΑ
MULLIONS FOR STORE FRONTS

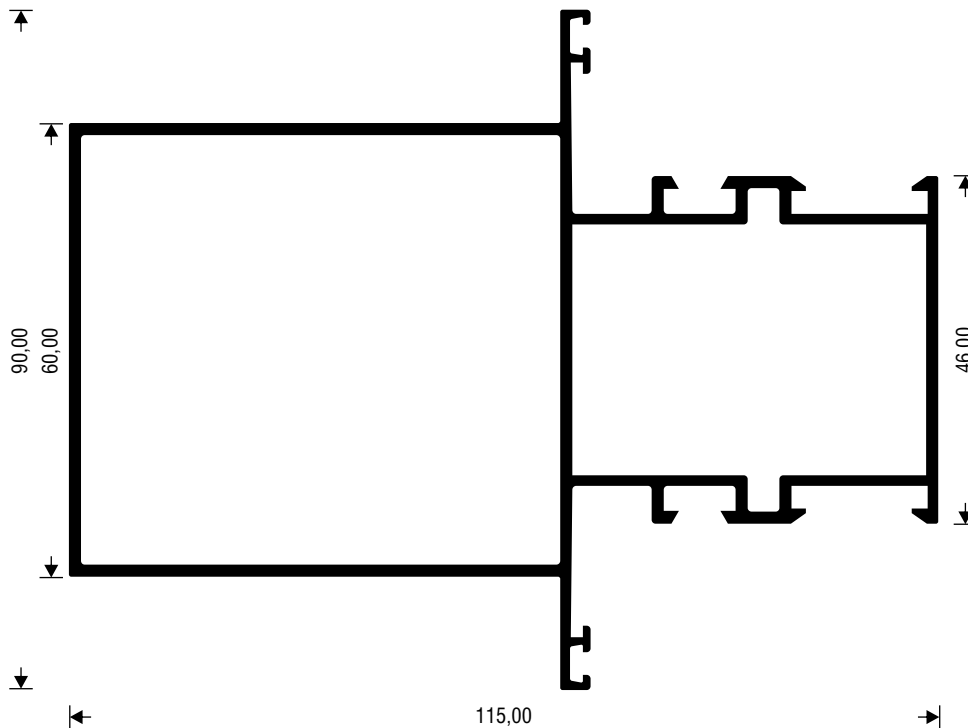

ΚΩΔ. ΣΥΝΔΕΣΜΟΥ / "T" CONNECTOR CODE:
160-11-233-00, 160-11-833-00
ή / or
165-47-330-00, 165-11-001-00, 165-11-002-00
ΚΩΔ. ΟΔΗΓΟΥ ΤΡΥΠ / DRILLING GUIDE CODE:
165-00-001-00

ΚΩΔ. ΞΥΛΟΥΡΙΣΤΙΚΟ / MILLING BIT CODE:
852-15-083-00

M 15085

W=1728 gr/m

ΚΟΛΩΝΑ "ΤΑΦ" ΚΑΜΠΥΛΗ
MULLIONS FOR STORE FRONTS

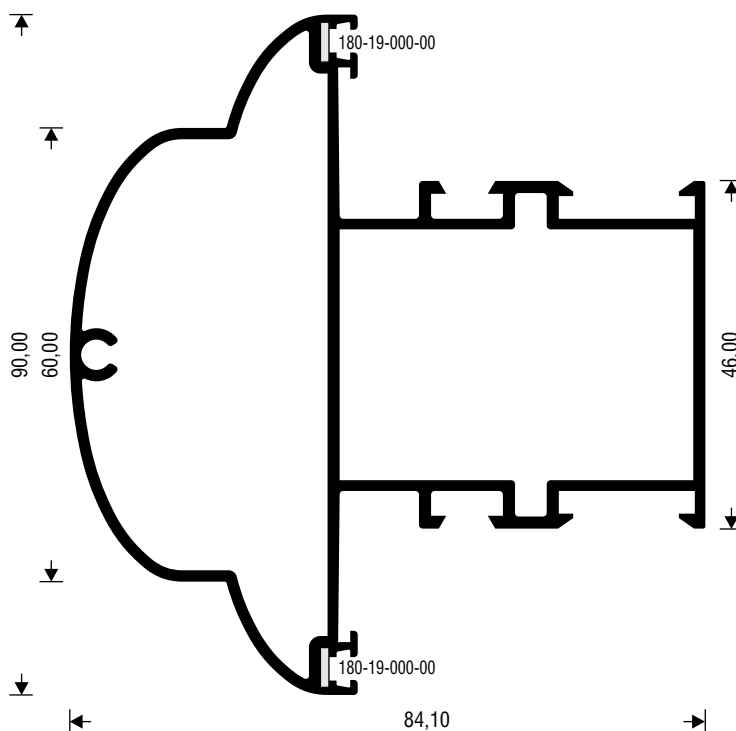

ΚΩΔ. ΣΥΝΔΕΣΜΟΥ / "T" CONNECTOR CODE:
160-11-233-00, 160-11-833-00
ή / or
165-47-330-00, 165-11-001-00, 165-11-002-00
ΚΩΔ. ΟΔΗΓΟΥ ΤΡΥΠ / DRILLING GUIDE CODE:
165-00-001-00

ΚΩΔ. ΞΥΛΟΥΡΙΣΤΙΚΟ / MILLING BIT CODE:
852-15-088-00

M 15088

W=1857 gr/m

ΚΟΛΩΝΑ "ΤΑΦ" ΚΑΜΠΥΛΗ
MULLIONS FOR STORE FRONTS

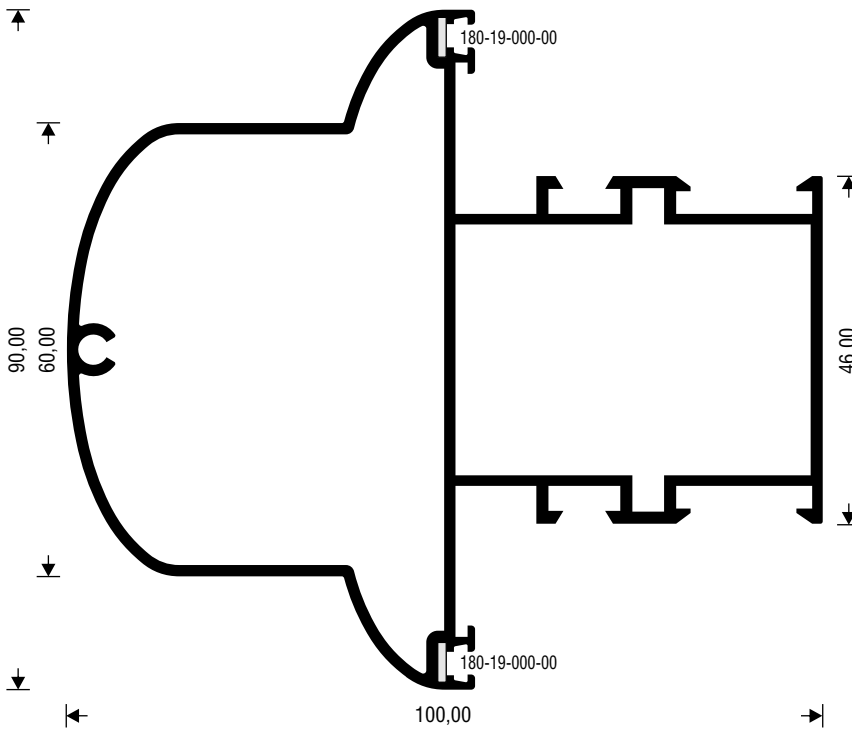

ΚΩΔ. ΣΥΝΔΕΣΜΟΥ / "T" CONNECTOR CODE:
160-11-233-00, 160-11-833-00
ή / or
165-47-330-00, 165-11-001-00, 165-11-002-00
ΚΩΔ. ΟΔΗΓΟΥ ΤΡΥΠ / DRILLING GUIDE CODE:
165-00-001-00

ΚΩΔ. ΞΥΛΟΥΡΙΣΤΙΚΟ / MILLING BIT CODE:
852-15-088-00

M 15086

W=1979 gr/m

ΚΟΛΩΝΑ "ΤΑΦ" ΚΑΜΠΥΛΗ
MULLIONS FOR STORE FRONTS

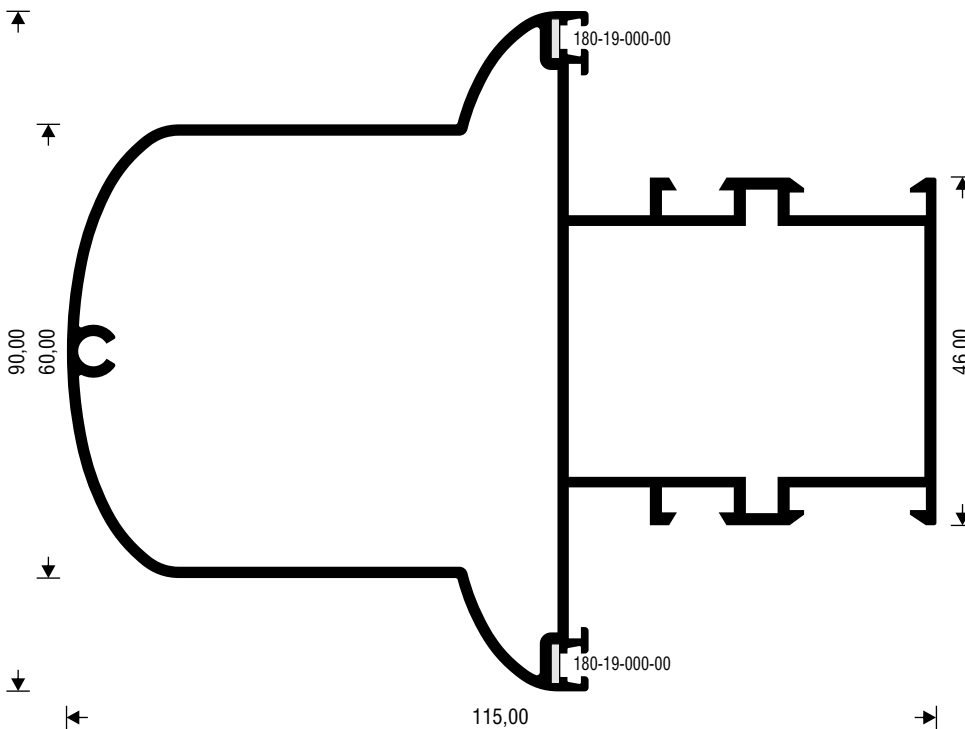

ΚΩΔ. ΣΥΝΔΕΣΜΟΥ / "T" CONNECTOR CODE:
160-11-233-00, 160-11-833-00
ή / or
165-47-330-00, 165-11-001-00, 165-11-002-00
ΚΩΔ. ΟΔΗΓΟΥ ΤΡΥΠ / DRILLING GUIDE CODE:
165-00-001-00

ΚΩΔ. ΞΥΛΟΥΡΙΣΤΙΚΟ / MILLING BIT CODE:
852-15-088-00

M 15067

W=2061 gr/m

ΤΑΜΠΛΑΣ 59 mm
KICKPLATE 59 mm

M 15142

W=1982 gr/m

ΤΑΜΠΛΑΣ
KICKPLATE

ΠΡΟΣΟΧΗ:
ΣΥΝΕΡΓΑΖΕΤΑΙ ΜΟΝΟ ΜΕ ΤΑ ΦΥΛΛΑ
M15033, M15035, M15393
CAUTION:
USED WITH SASHES
M15033, M15035 AND M15393 ONLY

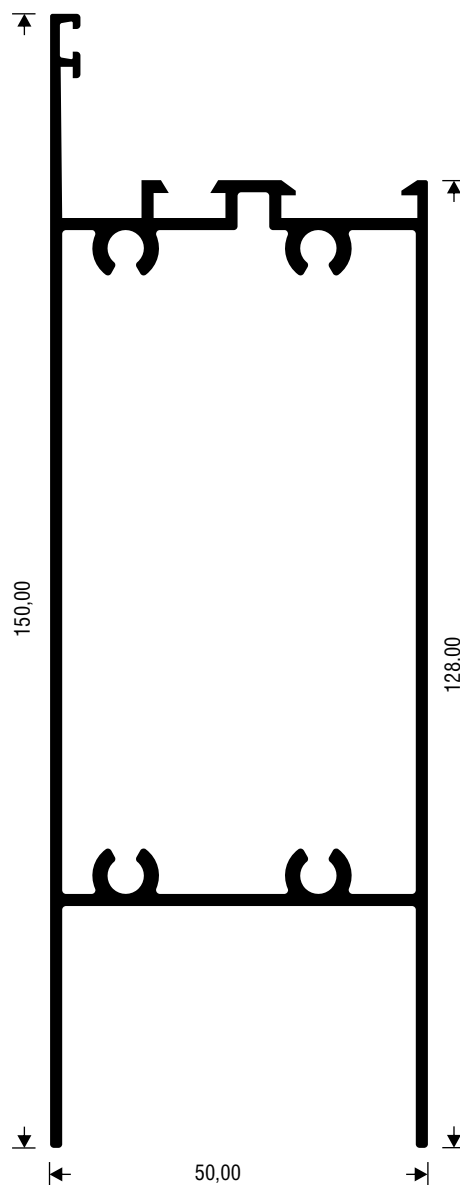
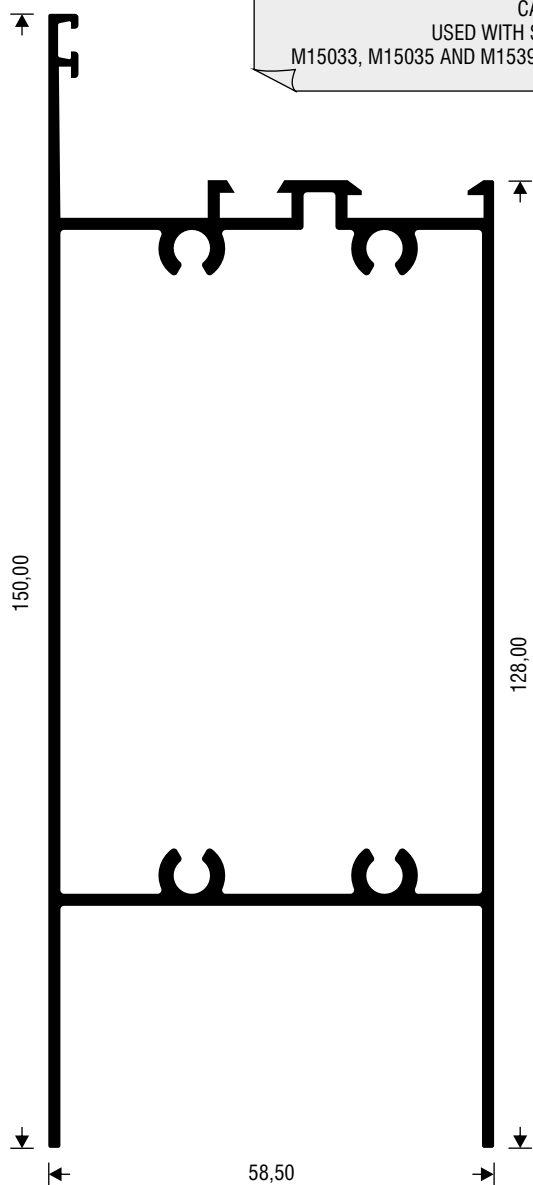

ΚΩΔ. ΕΥΛΟΥΠΙΣΤΙΚΟ / MILLING BIT CODE: 852-15-060-00

ΚΩΔ. ΕΥΛΟΥΠΙΣΤΙΚΟ / MILLING BIT CODE: 852-15-060-00

M 15143
W=2077 gr/m

ΤΑΜΠΛΑΣ
KICKPLATE

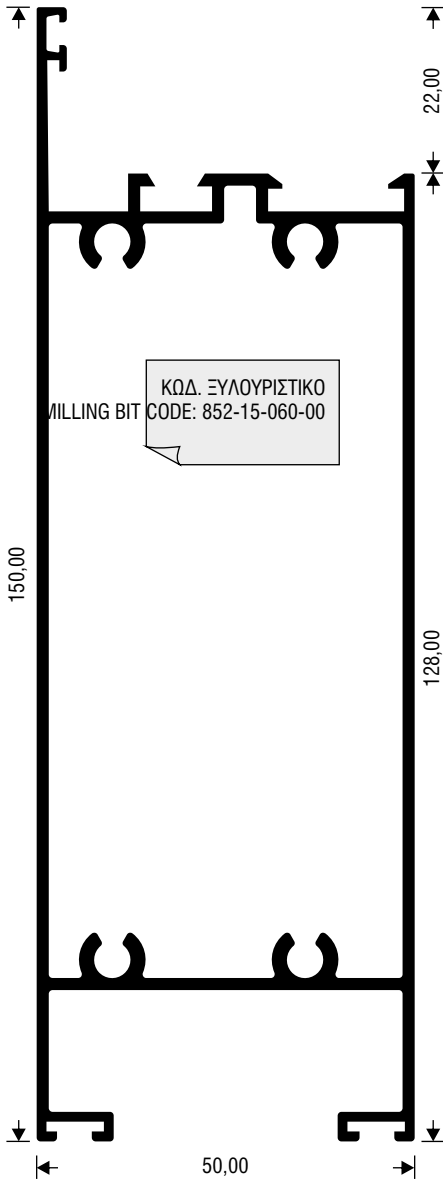

M 15192
W=1710 gr/m

ΤΑΜΠΛΑΣ
KICKPLATE

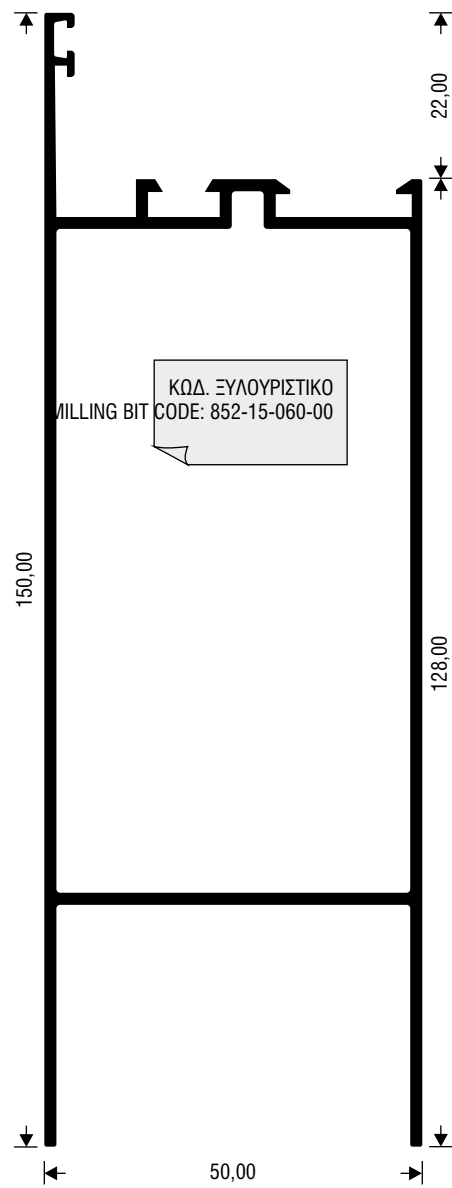

M 15157
W=820 gr/m

ΠΡΟΦΙΛ ΑΝΑΣΤΡΟΦΗΣ ΦΥΛΛΟΥ
SUPPLEMENTARY PROFILE
TO REVERSE FRAME

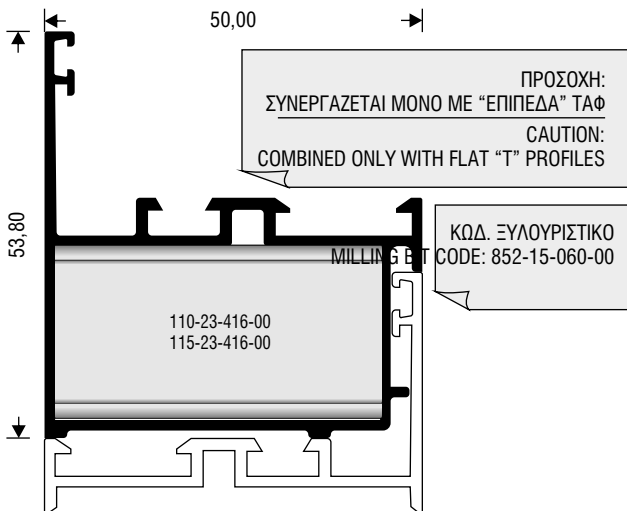

M 15170
W=611 gr/m

ΤΕΛΕΙΩΜΑ ΦΥΛΛΩΝ ΕΙΣΟΔΟΥ
SUPPLEMENTARY PROFILE FOR
SEALING THRESHOLD

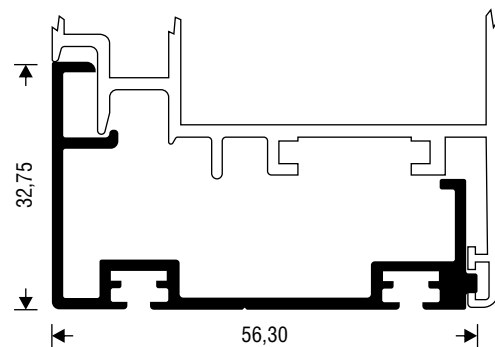

ΚΩΔ. ΤΑΠΑΣ / PLASTIC ENDCAP CODE: 310-15-170-00

ΕΙΣΟΔΟΙ ΜΕ ΕΞΩΤΕΡΙΚΟΥΣ ΜΕΝΤΕΣΕΔΕΣ ENTRANCES USING UNIVERSAL HINGES

M 15182

W=1449 gr/m

ΦΥΛΛΟ ΕΙΣΟΔΟΥ ΑΝΟΙΓΟΜΕΝΟ ΜΕΣΑ
ENTRANCE SASH OPENING INWARDS

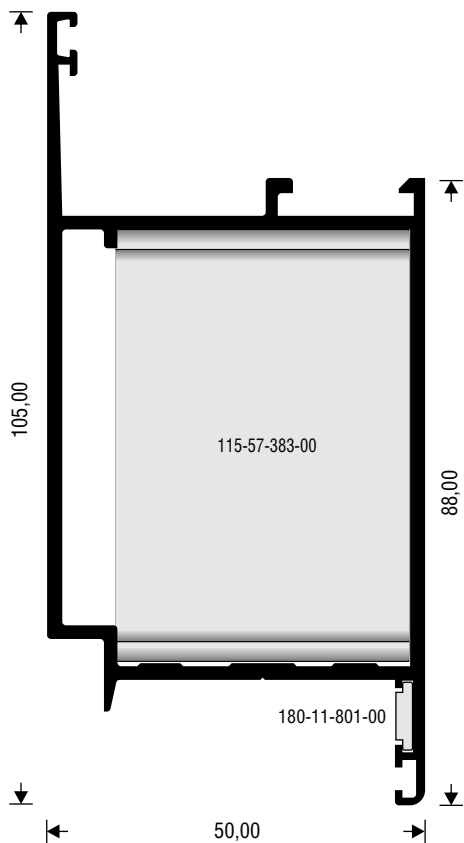

M 15076

W=1426 gr/m

ΦΥΛΛΟ ΕΙΣΟΔΟΥ ΑΝΟΙΓΟΜΕΝΟ ΕΞΩ
ENTRANCE SASH
OPENING OUTWARDS

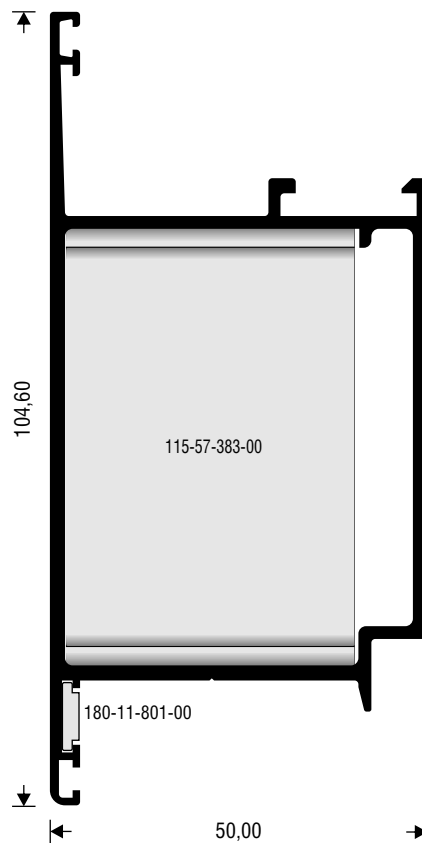

M 15078

W=1079 gr/m

ΚΑΣΑ ΕΙΣΟΔΟΥ
MAIN ENTRANCE FRAME

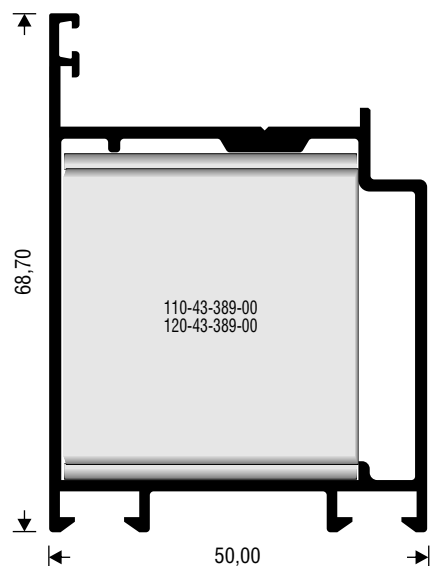

M 15191

W=751 gr/m

ΜΠΙΝΙ ΕΙΣΟΔΟΥ
MEETING STILE FOR DOORS

ΚΩΔ. ΤΑΠΑΣ / PLASTIC ENDCAP CODE: 310-15-191-00

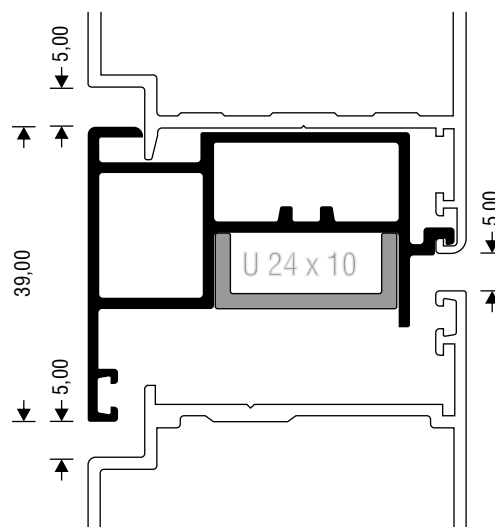

U 24 x 10

W=216 gr/m

ΠΡΟΣΘΗΚΗ ΜΠΙΝΙΟΥ
COVER PROFILE

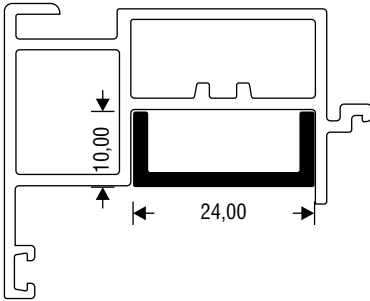

M 15162

W=754 gr/m

ΠΡΟΦΙΛ ΑΝΑΣΤΡΟΦΗΣ ΦΥΛΛΟΥ
SUPPLEMENTARY PROFILE
TO REVERSE FRAME

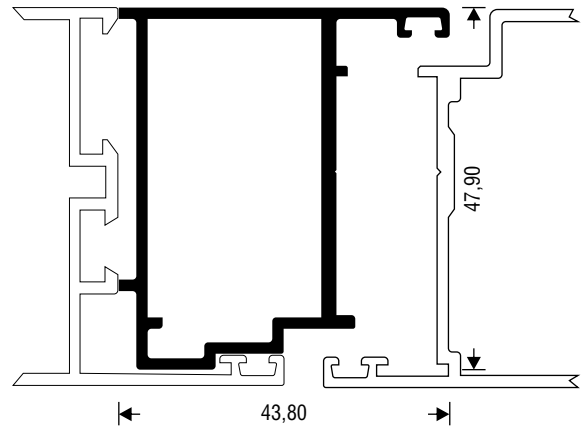

M 15171

W=505 gr/m

ΤΕΛΕΙΩΜΑ ΦΥΛΛΩΝ ΕΙΣΟΔΟΥ
SUPPLEMENTARY PROFILE FOR
SEALING THRESHOLD

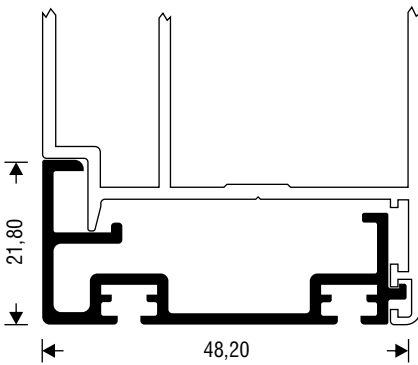

ΚΩΔ. ΤΑΠΑΣ / PLASTIC ENDCAP CODE: 310-15-171-00

M 15185

W=304 gr/m

ΚΟΥΜΠΩΜΑ ΕΙΣΟΔΟΥ
SUPPLEMENTARY PROFILE
FOR STORE FRONTS

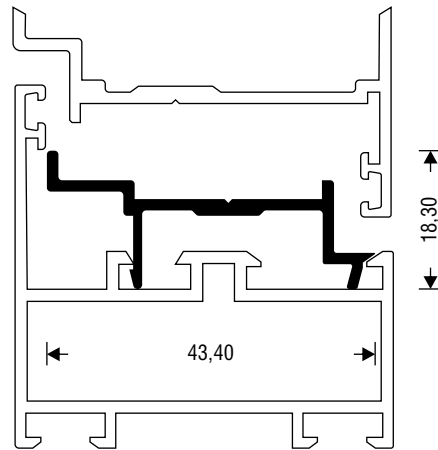

M 15183

W=928 gr/m

ΣΥΜΠΛΗΡΩΜΑ ΦΥΛΛΟΥ ΕΙΣΟΔΟΥ
SUPPLEMENTARY PROFILE FOR SASH
(KICKPLATE EFFECT)

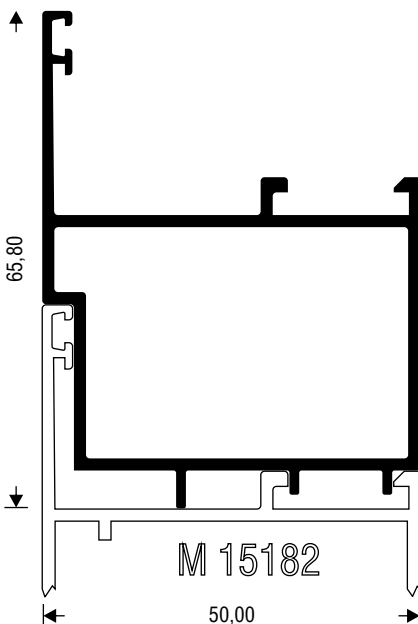

M 15176

W=437 gr/m

ΔΙΑΚΟΣΜΗΤΙΚΟ ΧΩΡΙΣΜΑ ΤΖΑΜΙΟΥ
GIVE - ON GLAZING TRANSOMS

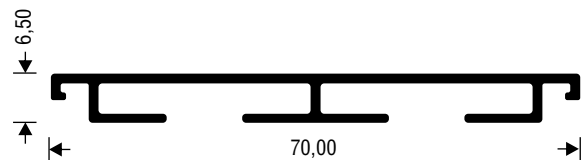

M 15175

W=209 gr/m

ΔΙΑΚΟΣΜΗΤΙΚΟ ΧΩΡΙΣΜΑ ΤΖΑΜΙΟΥ
GIVE - ON GLAZING TRANSOMS



ΕΙΣΟΔΟΣ "ΑΛΕ - ΡΕΤΟΥΡ" SASH FOR DOUBLE SWINGING DOORS

M 15576

W=1157 gr/m

ΦΥΛΛΟ ΓΙΑ "ΑΛΕ - ΡΕΤΟΥΡ"
SASH FOR DOUBLE SWINGING DOORS

M 15575

W=653 gr/m

ΠΡΟΣΘΕΤΟ ΚΑΣΑΣ ΓΙΑ "ΑΛΕ - ΡΕΤΟΥΡ"
SUPPLEMENTARY PROFILE
FOR DOUBLE SWINGING DOORS

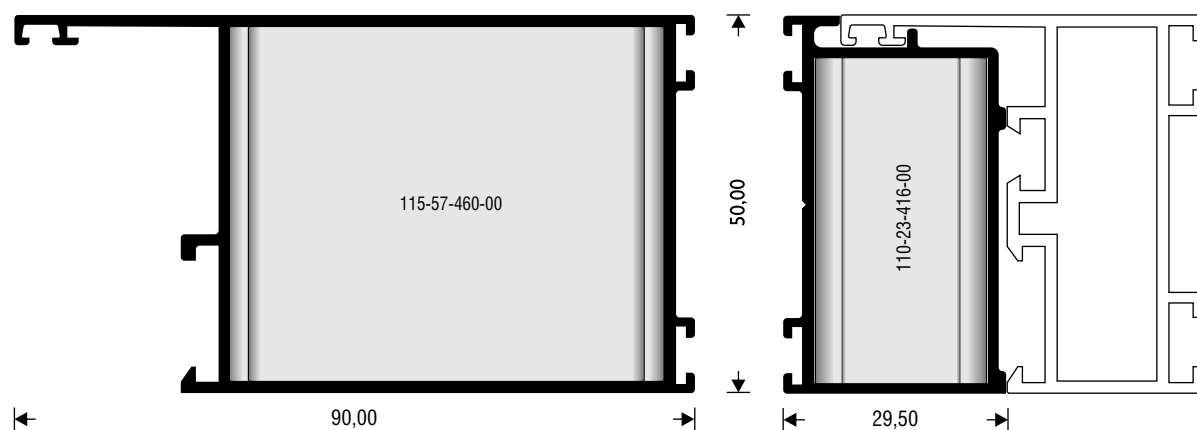

ΠΡΟΦΙΛ "ΚΡΥΦΟΥ ΦΥΛΛΟΥ" - CONCEALED SASH PROFILES

M 15408

W=987 gr/m

ΚΑΣΑ ΙΣΙΑ ΓΙΑ ΚΡΥΦΟ ΦΥΛΛΟ
FRAME FOR CONCEALED SASH

M 15028

W=911 gr/m

ΚΡΥΦΟ ΦΥΛΛΟ
CONCEALED SASH

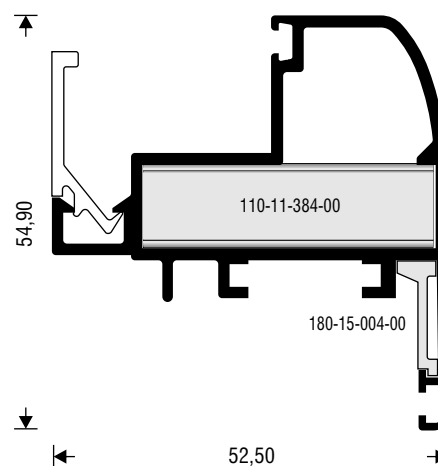
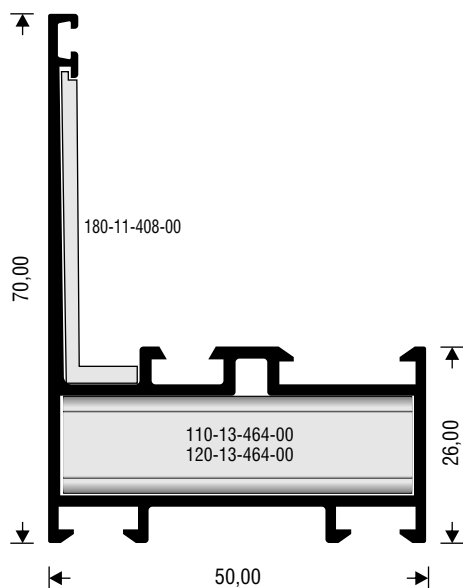

M 15416

W=1225 gr/m

“ΤΑΦ” ΙΣΙΟ

MULLION FOR CONCEALED SASH

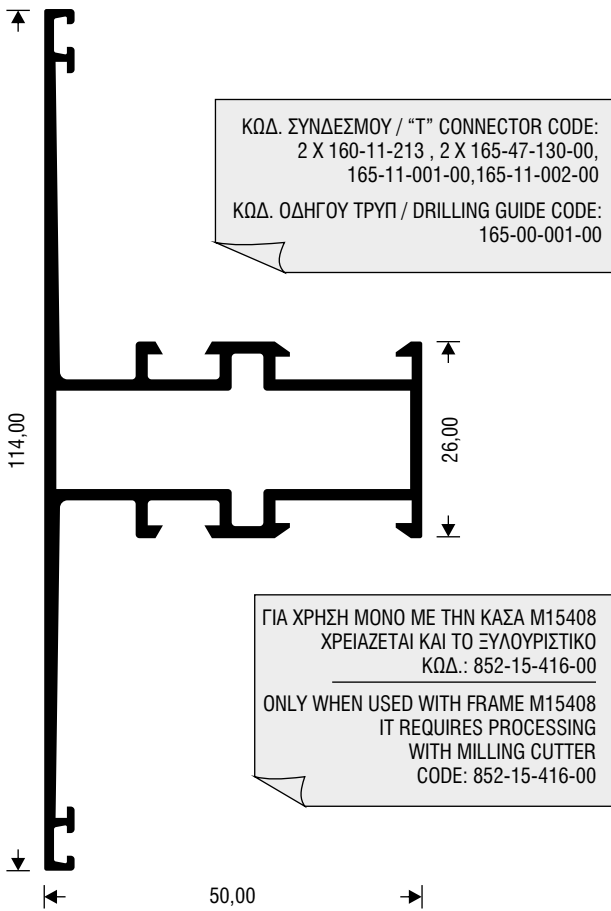

M 15417

W=1153 gr/m

“ΤΑΦ” ΙΣΙΟ

MULLION FOR CONCEALED SASH

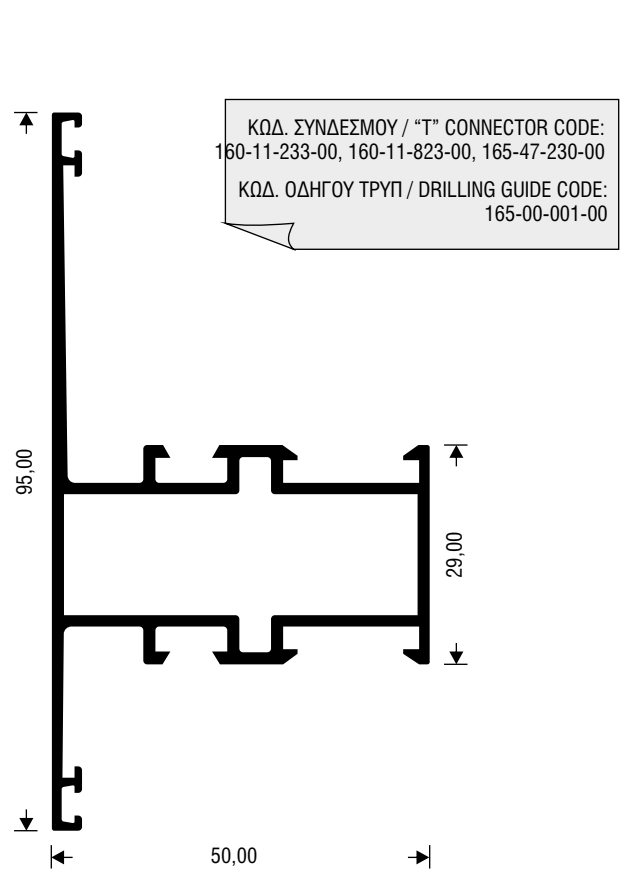

M 15200

W=853 gr/m

ΚΡΥΦΟ ΦΥΛΛΟ STRUCTURAL
CONCEALED SASH
WITH STRUCTURAL GLAZING

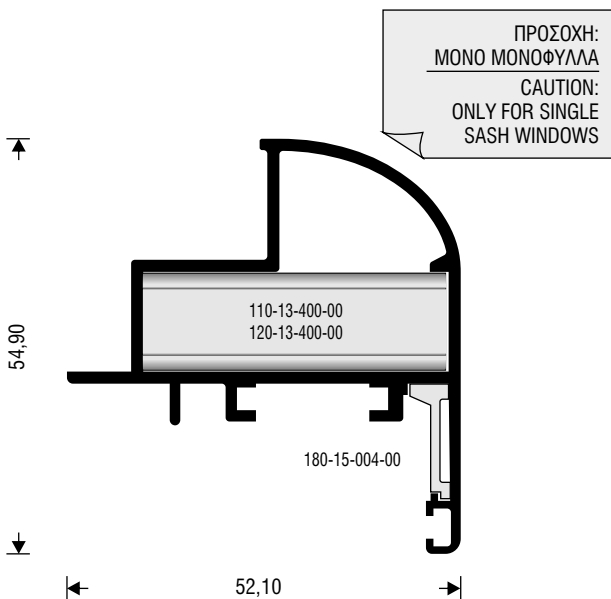

M 15421

W=989 gr/m

ΚΡΥΦΟ ΦΥΛΛΟ
CONCEALED SASH

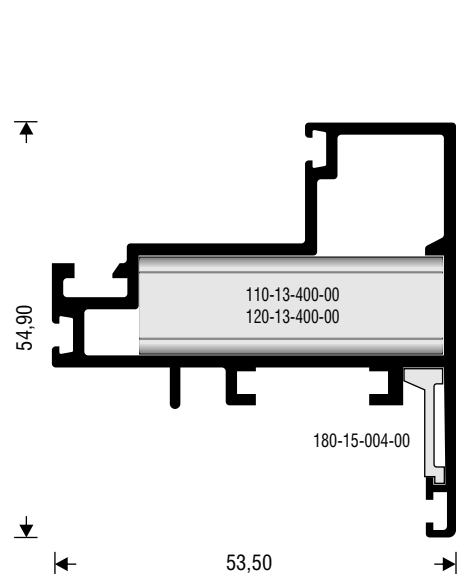

M 15458

W=1370 gr/m

ΜΠΙΝΙ

MEETING STILE FOR CONCEALED SASH

ΚΩΔ. ΤΑΠΑΣ / PLASTIC ENDCAP CODE: 300-15-458-00

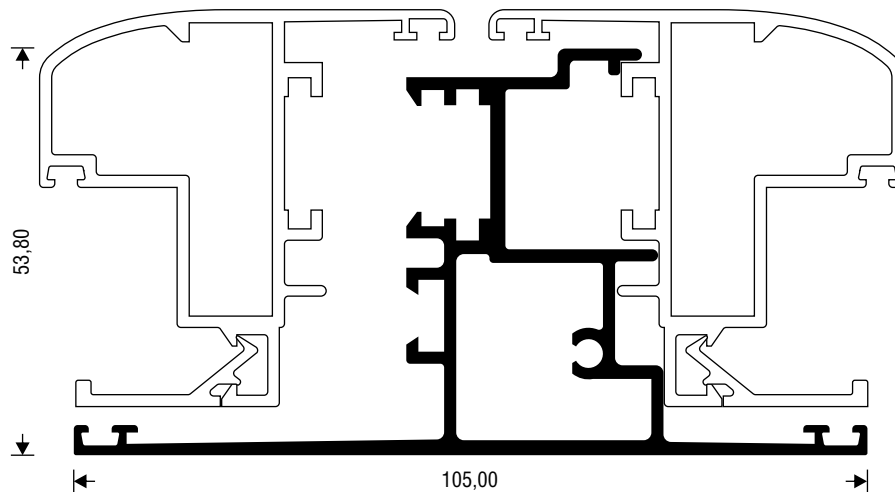

M 15029

W=968 gr/m

ΚΡΥΦΟ ΦΥΛΛΟ
CONCEALED SASH

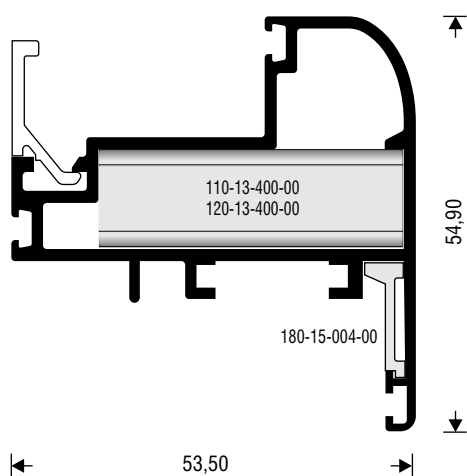

M 11482

W=351 gr/m

ΠΡΟΣΘΗΚΗ ΓΙΑ "ΤΑΦ"
ΚΡΥΦΟΥ ΦΥΛΛΟΥ
CLIP FOR TRANSOM

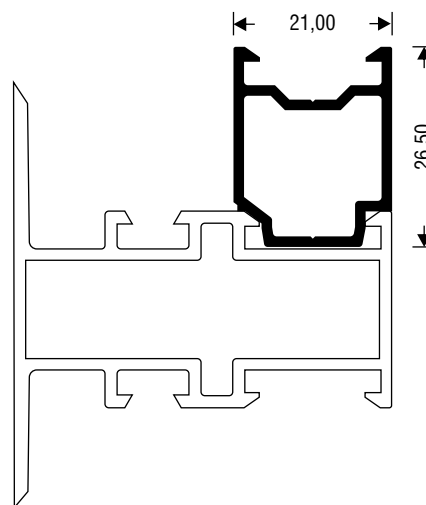

M 11457

W=114 gr/m

ΠΗΧΑΚΙ ΙΣΙΟ
GLAZING BEAD

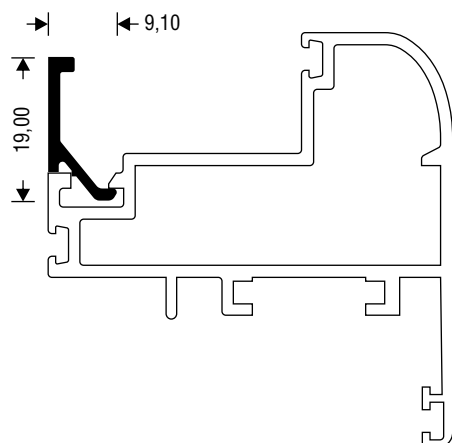

S 265

W=136 gr/m

ΠΗΧΑΚΙ ΙΣΙΟ
GLAZING BEAD

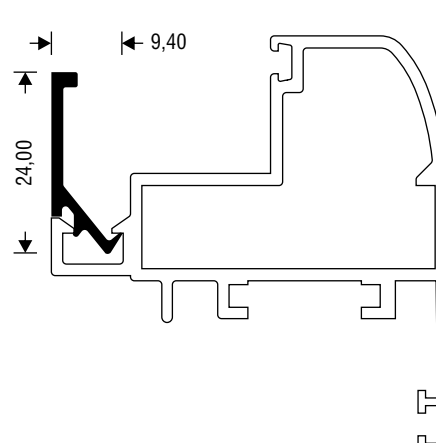

ΠΡΟΦΙΛ ΠΕΡΙΜΕΤΡΙΚΩΝ ΜΗΧΑΝΙΣΜΩΝ PROFILES WITH "SCREWED - ON" MECHANISMS

M 15377

W=1239 gr/m

ΦΥΛΛΟ
SASH

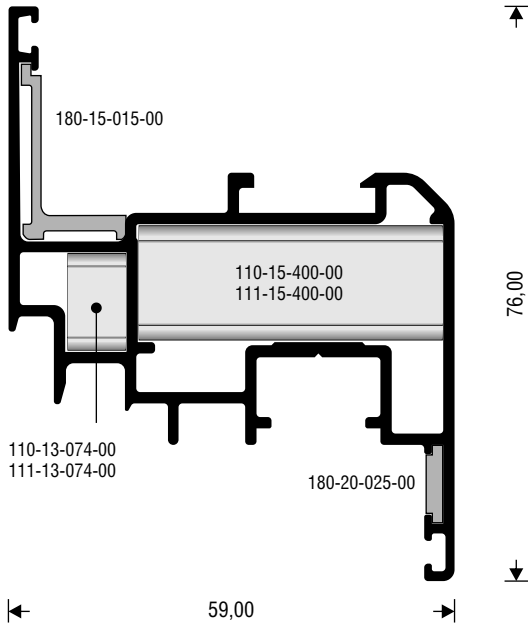

M 15376

W=1220 gr/m

ΦΥΛΛΟ
SASH

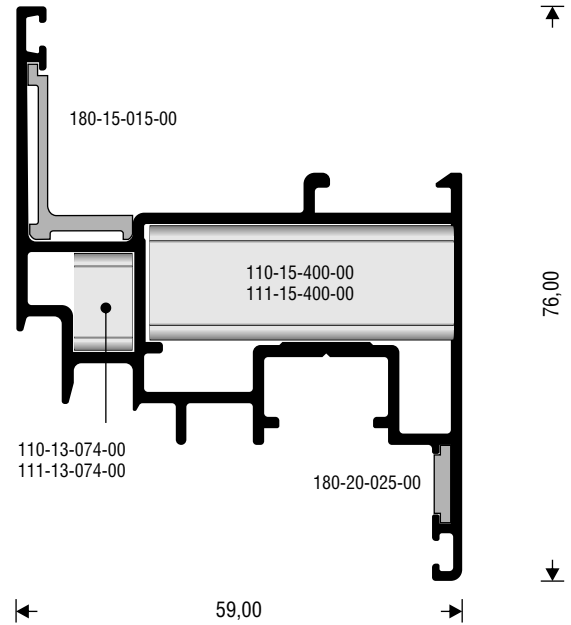

M 15373

W=1282 gr/m

ΦΥΛΛΟ
SASH

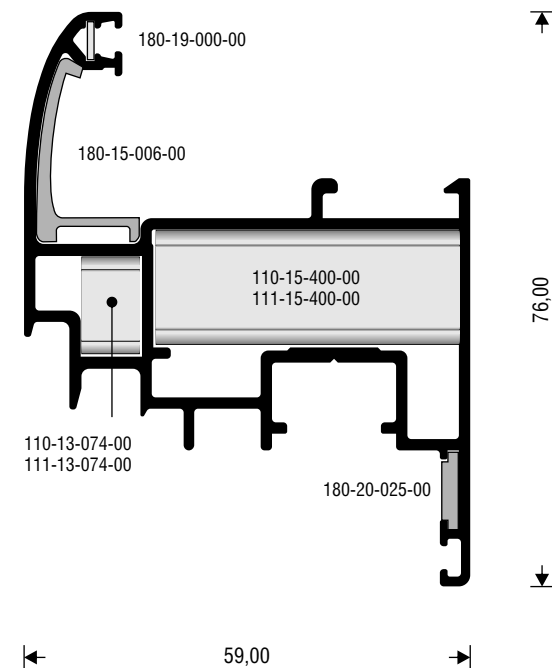

M 15378

W=1303 gr/m

ΦΥΛΛΟ
SASH

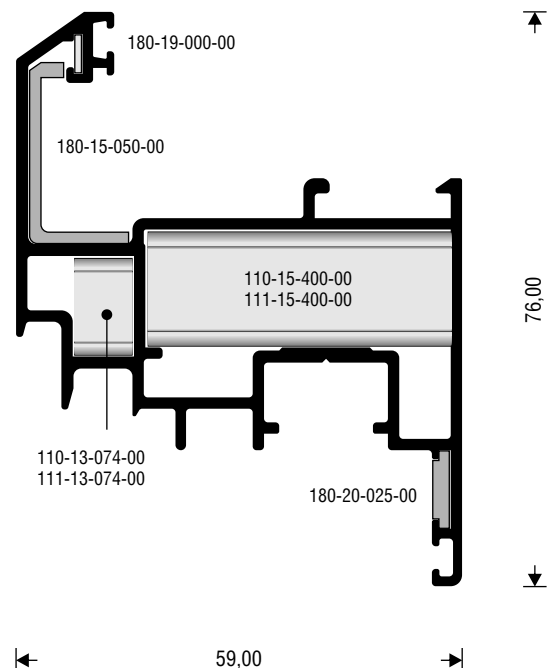

ΠΡΟΣΟΧΗ: ΓΙΑ ΠΑΡΑΘΥΡΑ ΜΕ ΠΕΡΙΜΕΤΡΙΚΟ ΜΗΧΑΝΙΣΜΟ ΧΡΗΣΙΜΟΠΟΙΟΥΝΤΑΙ ΜΟΝΟ ΟΙ ΚΑΣΕΣ ΜΕ ΥΨΟΣ ΘΑΛΑΜΟΥ 23 ΚΑΙ 33 mm
CAUTION: FOR "PVC - GROOVE" MECHANISMS USE ONLY FRAMES WITH 23 OR 33 mm CHAMBER HEIGHT

M 15379
W=1083 gr/m

ΜΠΙΝΙ ΙΣΙΟ
MEETING STILE

ΚΩΔ. ΤΑΠΑΣ / PLASTIC ENDCAP CODE: 300-15-379-00

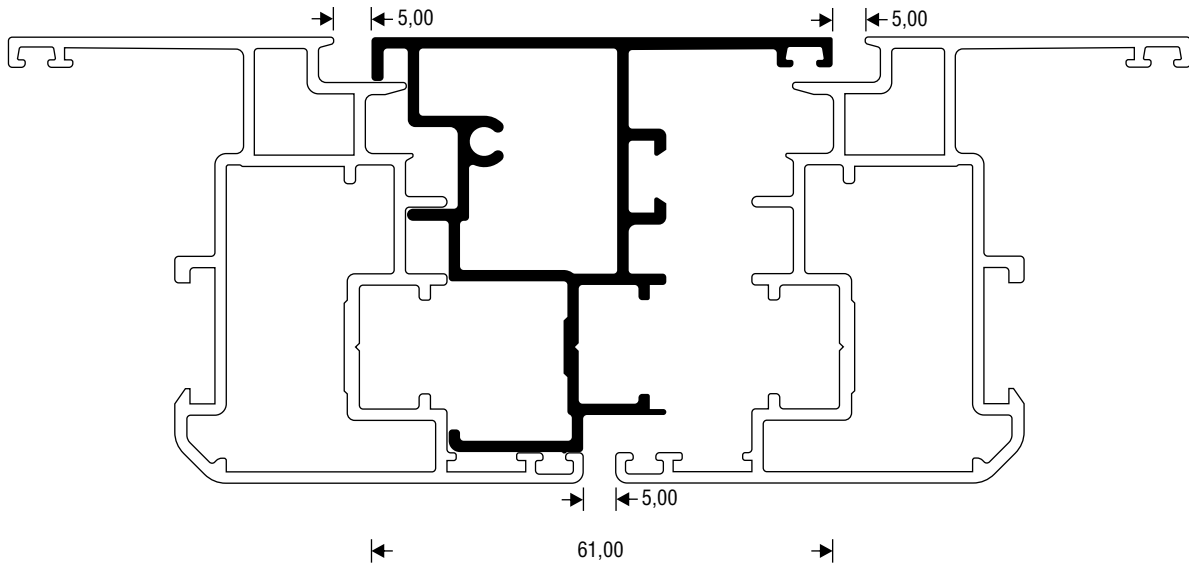

M 15375
W=1173 gr/m

ΜΠΙΝΙ
MEETING STILE

ΚΩΔ. ΤΑΠΑΣ / PLASTIC ENDCAP CODE: 300-15-375-00

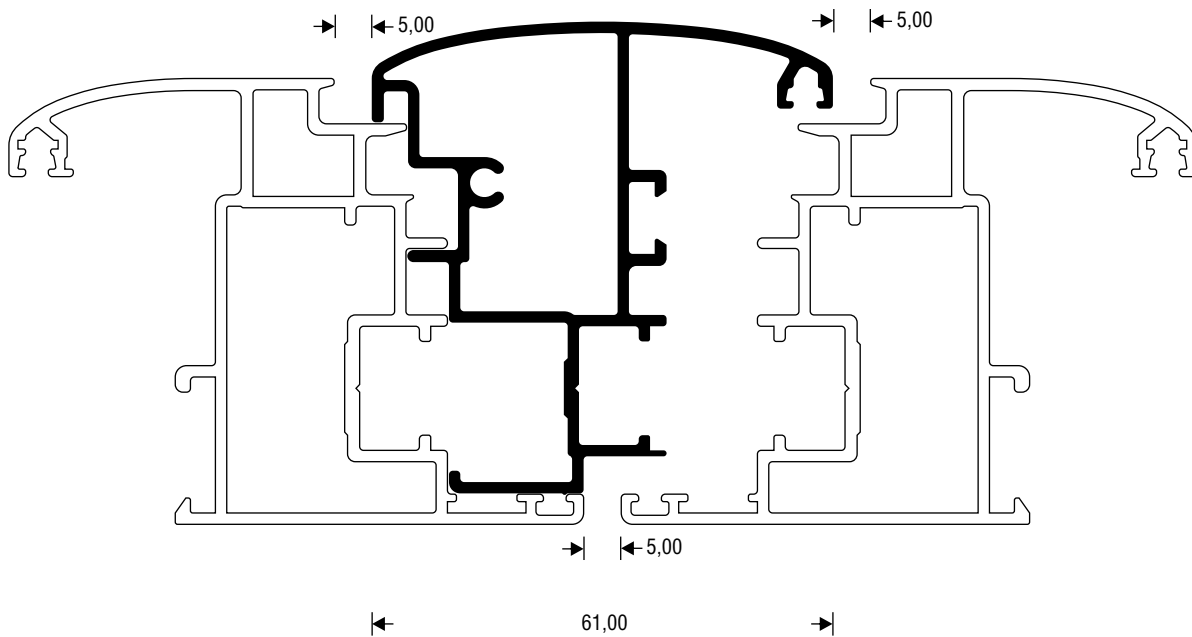

ΠΡΟΦΙΛ ΠΑΝΤΖΟΥΡΙΩΝ - SHUTTERS PROFILES

M 9300

W=756 gr/m

ΚΑΣΑ ΙΣΙΑ ΧΑΜΗΛΗ
FRAME SMALL FLAT

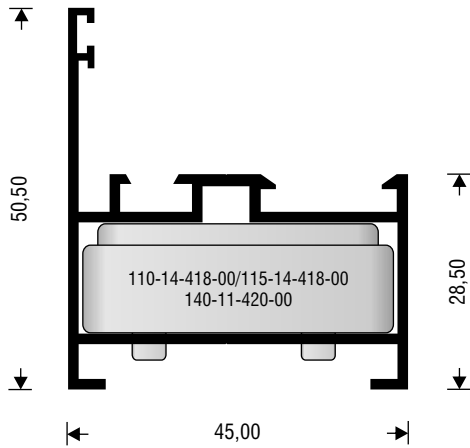

M 9395

W=944 gr/m

ΦΥΛΛΟ ΠΑΝΤΖΟΥΡΙΟΥ
SASH FOR SHUTTERS

ΧΩΡΙΣΜΑ: M9399 Ή M9393
"H" PROFILE: M9399 OR M9393

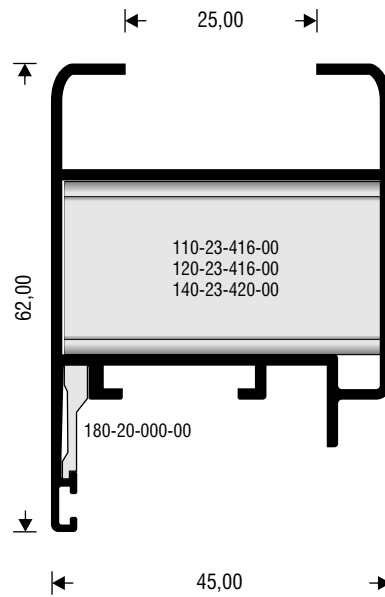

M 9398

W=631 gr/m

ΜΠΙΝΙ ΠΑΝΤΖΟΥΡΙΟΥ
MEETING STILE

ΚΩΔ. ΤΑΠΑΣ / PLASTIC ENDCAP CODE: 300-09-398-00

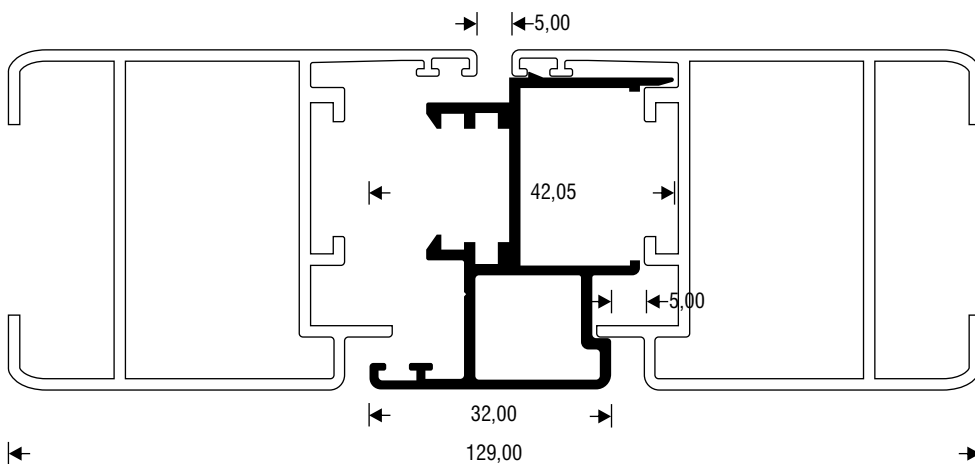

M 9393

W=1303 gr/m

ΧΩΡΙΣΜΑ
MULLION

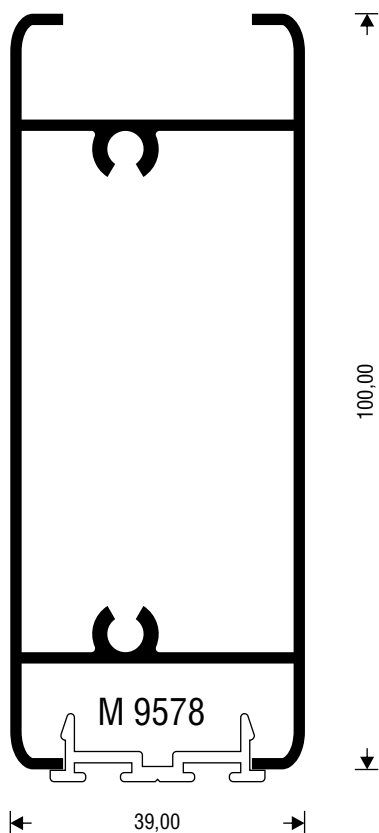

M 9394

W=1384 gr/m

ΤΑΜΠΛΑΣ
ΠΑΝΤΖΟΥΡΙΟΥ
KICKPLATE
FOR SHUTTERS

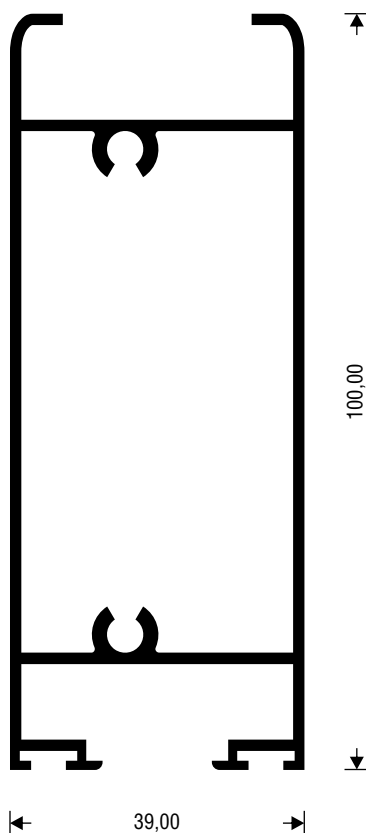

M 9399

W=1240 gr/m

ΧΩΡΙΣΜΑ ΓΙΑ
M9372, M9395
MULLION

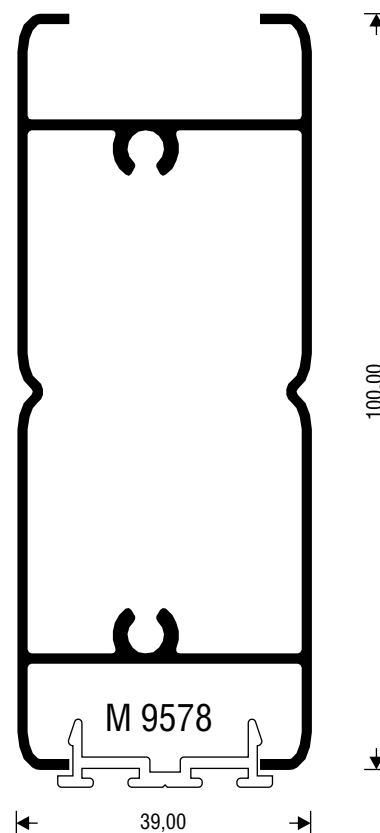

M 9564

W=604 gr/m

ΠΡΟΣΘΕΤΟ ΠΡΟΦΙΛ
SUPPLEMENTARY PROFILE

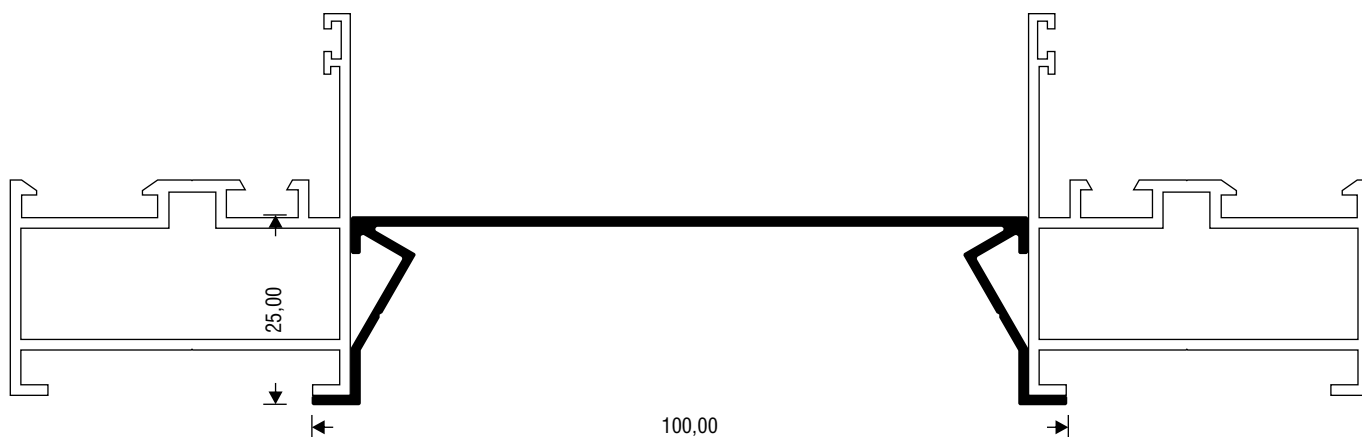

ΟΛΑ ΤΑ "ΓΑΛΟΝΑΚΙΑ" ΔΙΑΤΙΘΕΝΤΑΙ ΔΙΑΤΡΗΤΑ
 ALL SHUTTER BLIND PROFILES ARE PRE-PUNCHED TO ALLOW VENTILATION

M 9338 ΓΑΛΟΝΑΚΙ
 W=470 gr/m SHUTTER BLINDS

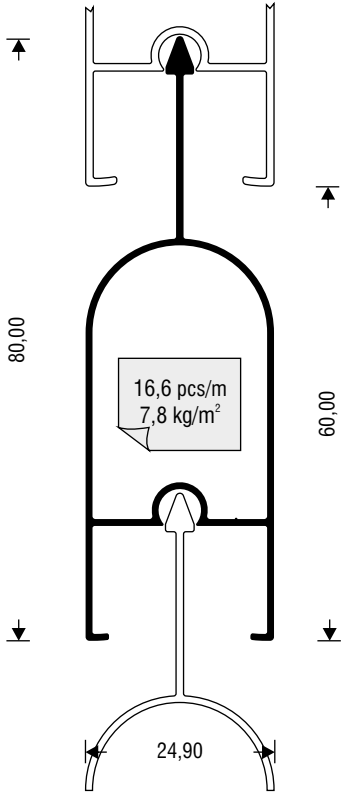

M 9338A ΓΑΛΟΝΑΚΙ
 W=526 gr/m SHUTTER BLINDS

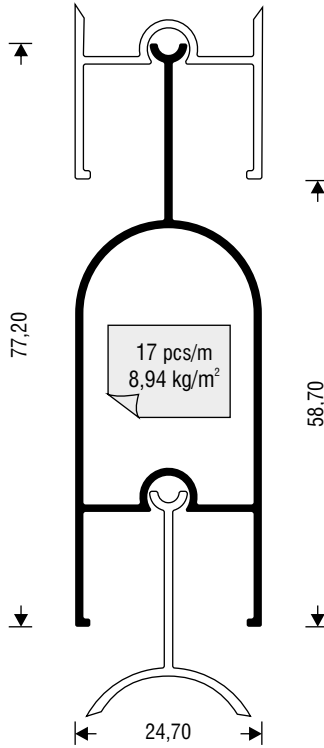

M 9353 ΓΑΛΟΝΑΚΙ
 W=511 gr/m SHUTTER BLINDS

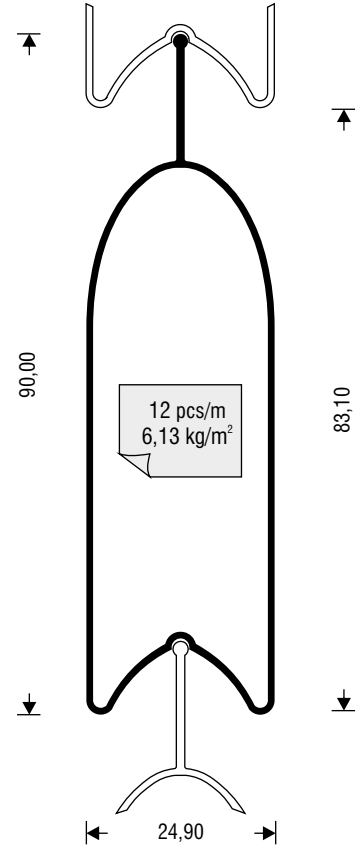

M 9538 ΓΑΛΟΝΑΚΙ
 W=520 gr/m SHUTTER BLINDS

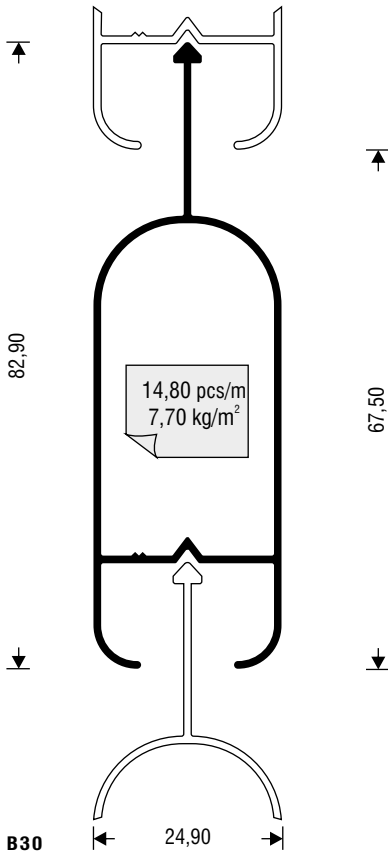

M 9558 ΓΑΛΟΝΑΚΙ
 W=483 gr/m SHUTTER BLINDS

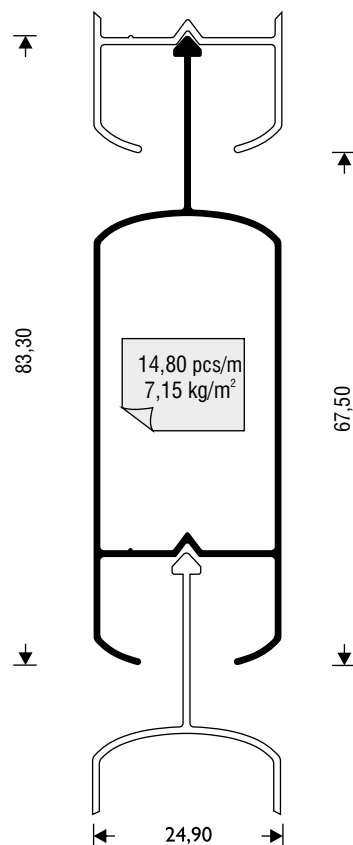

M 9553 ΓΑΛΟΝΑΚΙ
 W=582 gr/m SHUTTER BLINDS

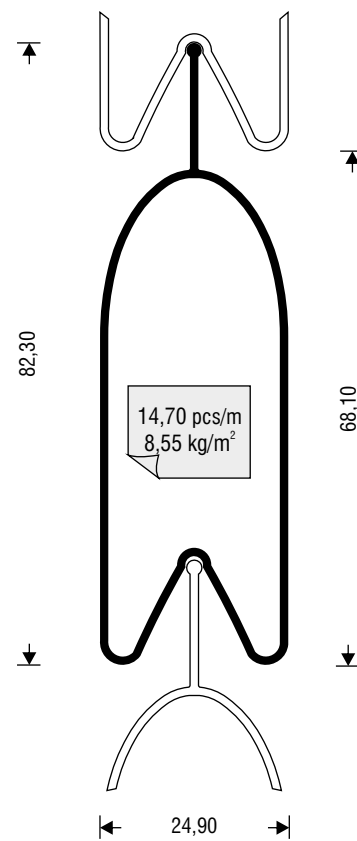

ΟΛΑ ΤΑ "ΓΑΛΟΝΑΚΙΑ" ΔΙΑΤΙΘΕΝΤΑΙ ΔΙΑΤΡΗΤΑ
ALL SHUTTER BLIND PROFILES ARE PRE-PUNCHED TO ALLOW VENTILATION

M 9368 ΓΑΛΟΝΑΚΙ
W=592 gr/m SHUTTER BLINDS

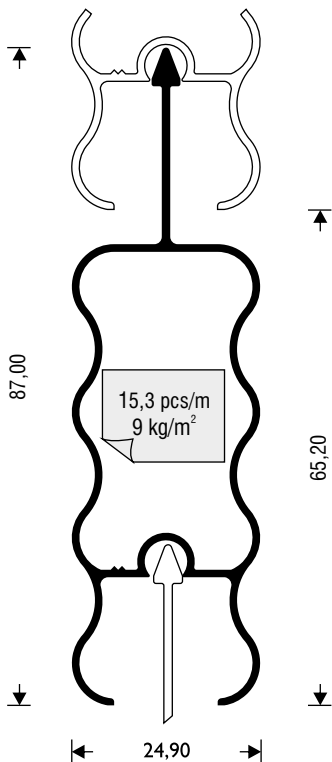

M 9357 ΓΑΛΟΝΑΚΙ
W=385 gr/m SHUTTER BLINDS

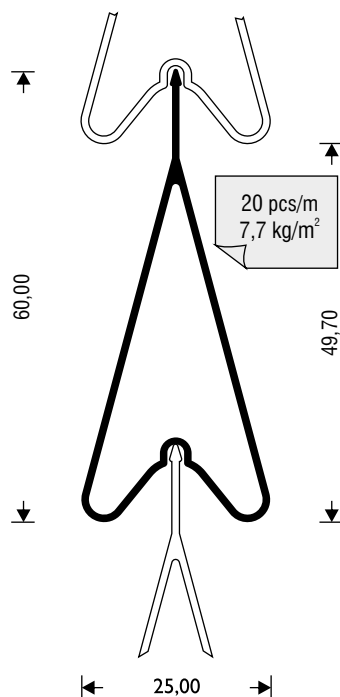

M 9559 ΓΑΛΟΝΑΚΙ
W=608 gr/m SHUTTER BLINDS

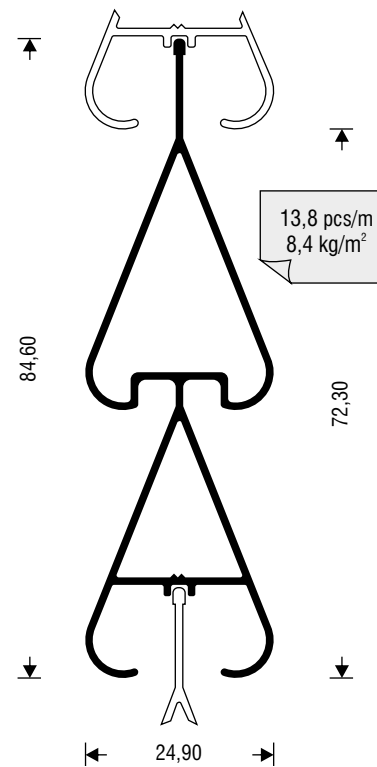

M 9342 ΓΑΛΟΝΑΚΙ
W=466 gr/m SHUTTER BLINDS

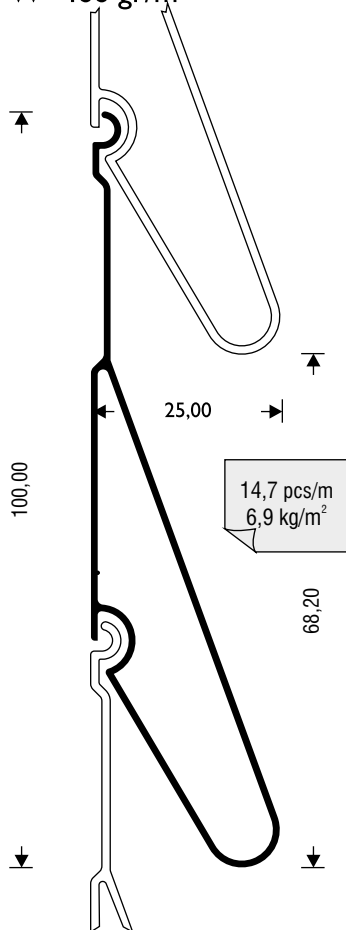

M 9356 ΓΑΛΟΝΑΚΙ
W=670 gr/m SHUTTER BLINDS

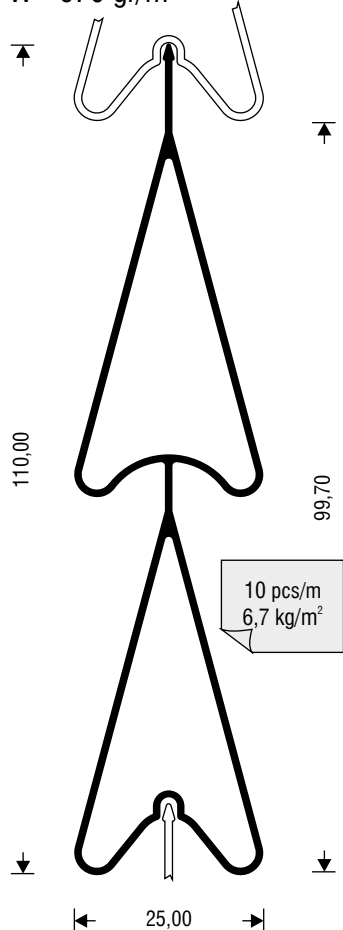

M 9534 ΓΑΛΟΝΑΚΙ
W=713 gr/m SHUTTER BLINDS

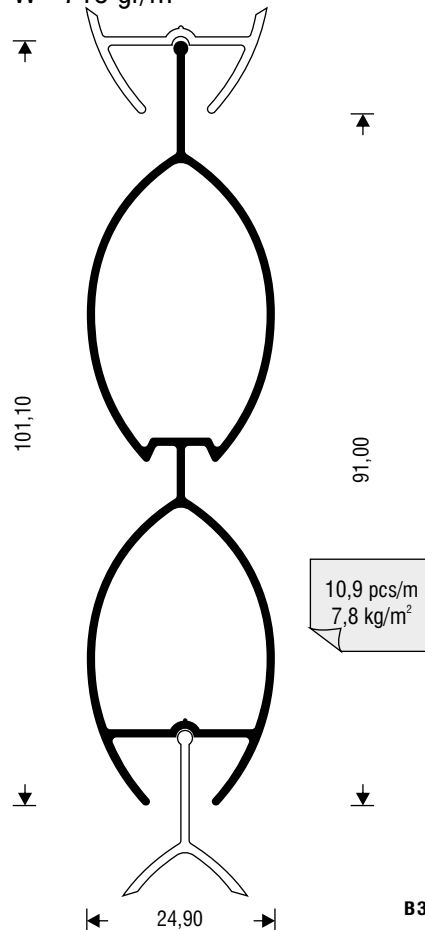

M 9348

W=280 gr/m

ΓΑΛΟΝΑΚΙ
SHUTTER BLINDS

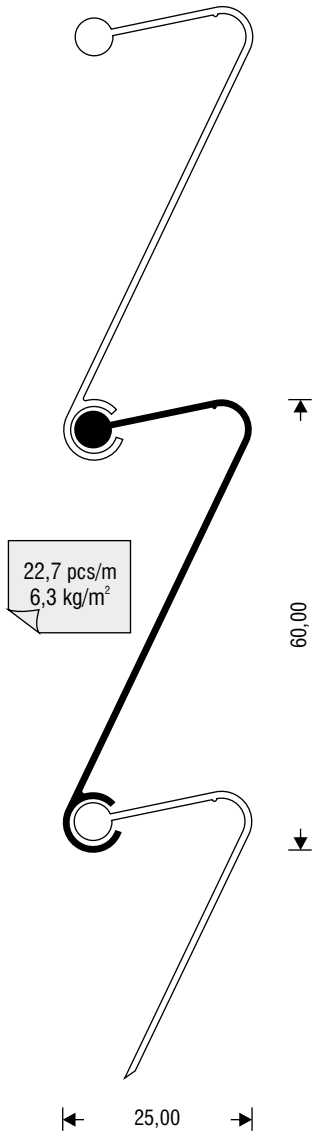

ΠΕΡΙΣΤΡΕΦΟΜΕΝΟ PIVOTING WINDOW

M 15128

W=1179 gr/m

ΦΥΛΛΟ ΠΕΡΙΣΤΡΕΦΟΜΕΝΟΥ
SASH FOR PIVOTING WINDOW

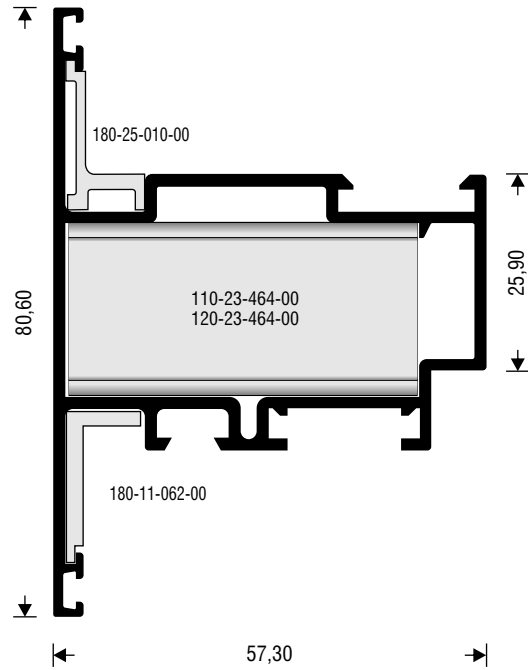

M 9578

W=209 gr/m

ΠΡΟΣΘΗΚΗ ΤΑΜΠΛΑ
SUPPLEMENTARY SEALING PROFILE
FOR KICKPLATES

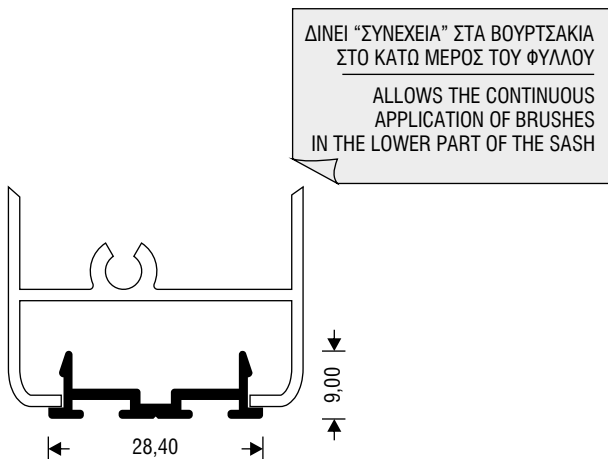

M 15132

W=1040 gr/m

ΜΠΙΝΙ ΠΕΡΙΣΤΡΕΦΟΜΕΝΟΥ
MEETING STILE FOR
PIVOTING WINDOW

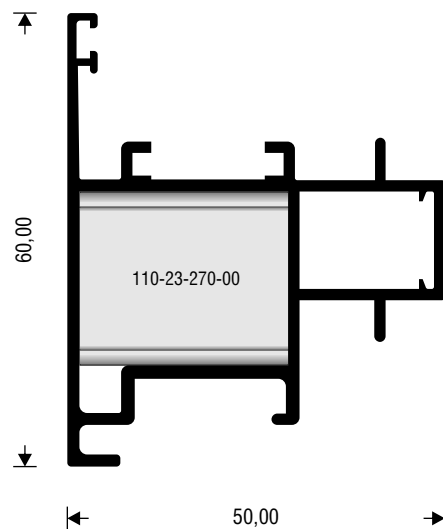

ΓΩΝΙΑΚΕΣ ΚΑΤΑΣΚΕΥΕΣ - CONSTRUCTION IN ANGLES

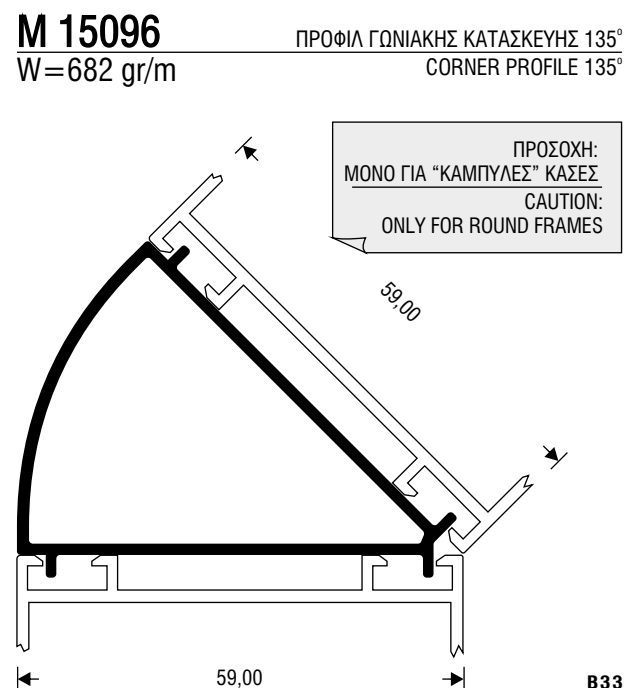
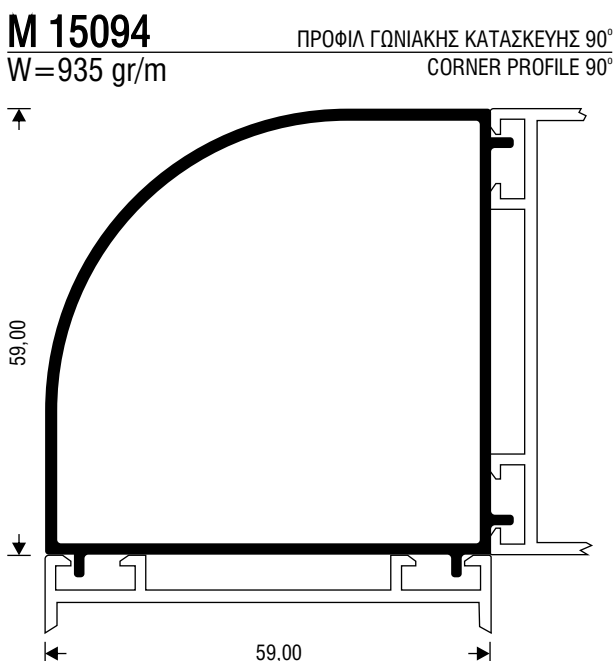
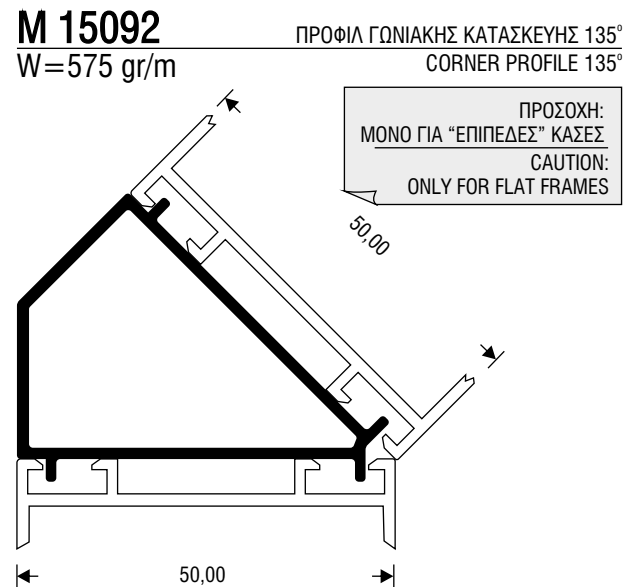
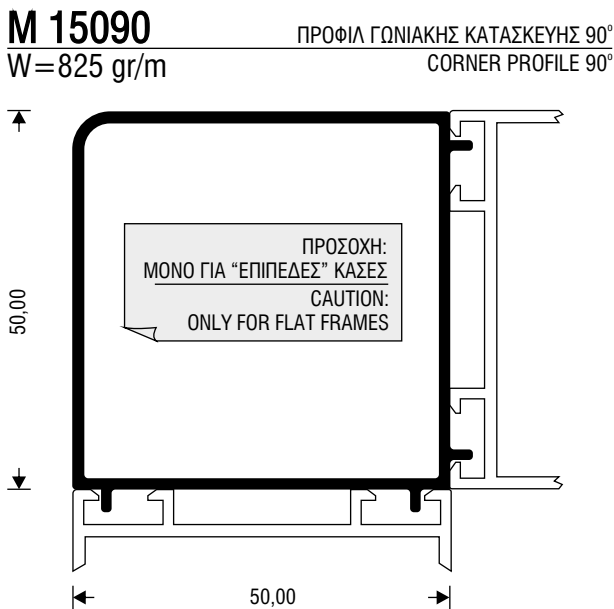
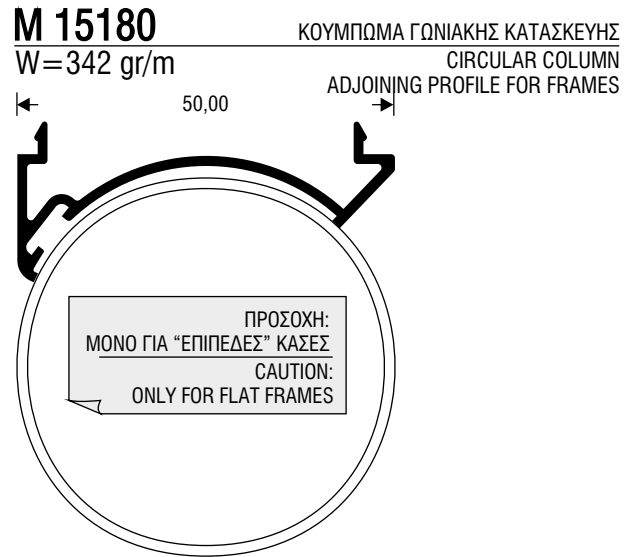
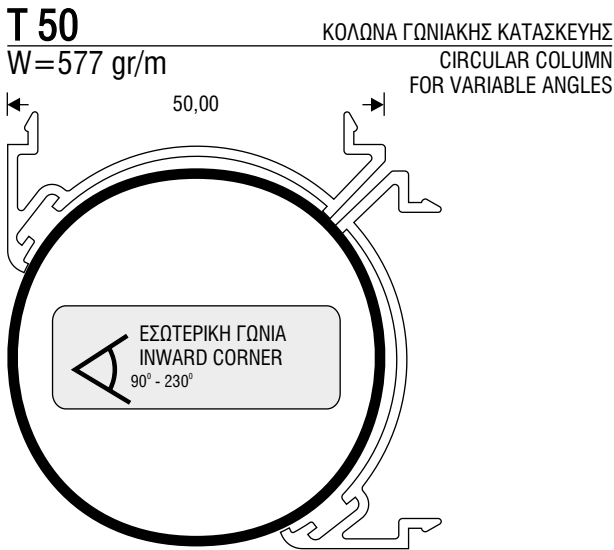

M 15100

W=691 gr/m

ΠΡΟΦΙΛ ΓΩΝΙΑΚΗΣ ΚΑΤΑΣΚΕΥΗΣ 135°
CORNER PROFILE 135°

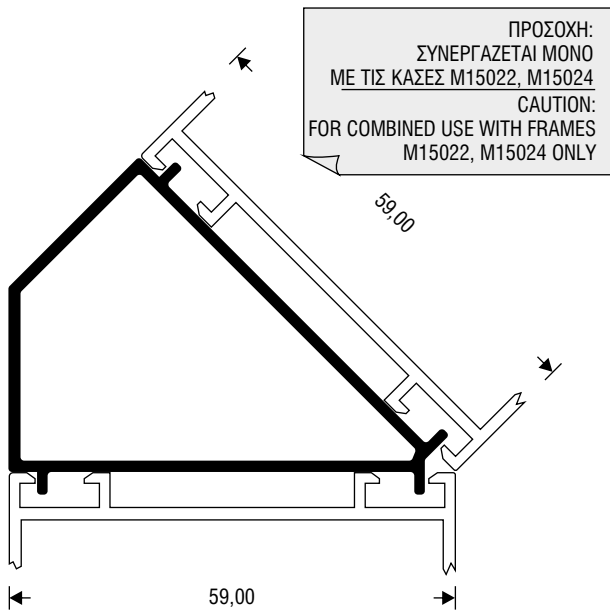

M 15098

W=895 gr/m

ΠΡΟΦΙΛ ΓΩΝΙΑΚΗΣ ΚΑΤΑΣΚΕΥΗΣ 90°
CORNER PROFILE 90°

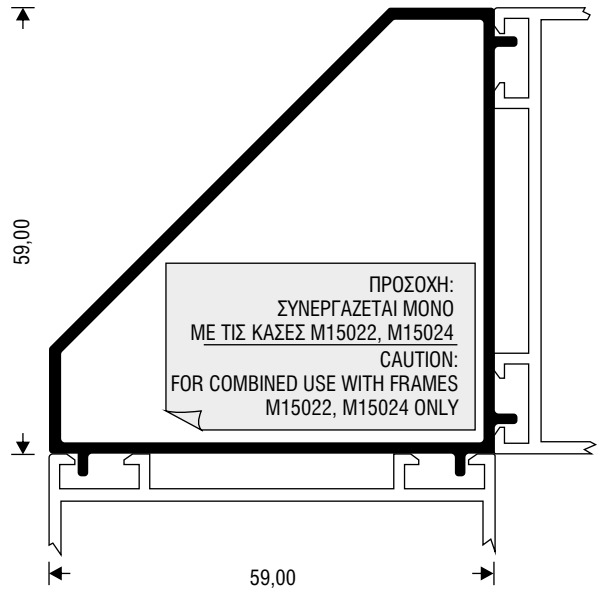

M 15474

W=837 gr/m

ΛΕΚΑΝΗ ΑΠΟΡΡΟΗΣ
WATER EVACUATION PROFILE

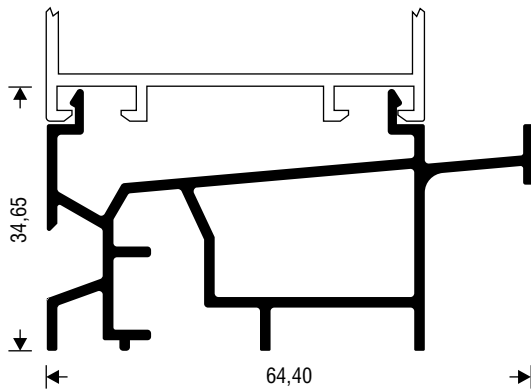

M 15173

W=466 gr/m

ΚΑΤΩΚΑΣΙ
THRESHOLD

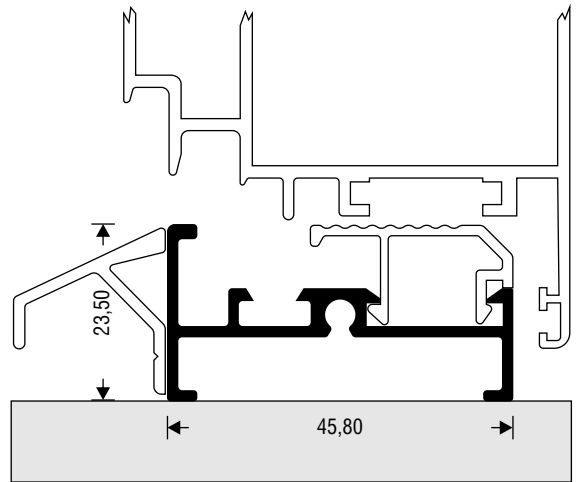

M 15172

W=281 gr/m

ΚΑΤΩΚΑΣΙ
THRESHOLD

ΚΩΔ. ΣΥΝΔΕΣΜΟΥ / THRESHOLD CONNECTOR CODE: 310-15-172-00

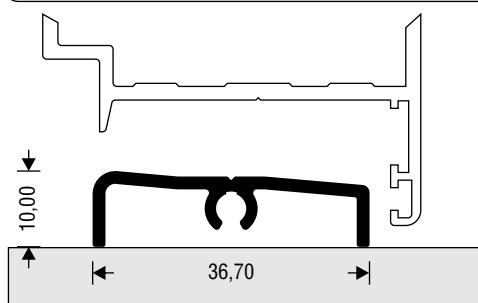

M 15577

W=291 gr/m

ΚΑΤΩΚΑΣΙ
THRESHOLD

ΚΩΔ. ΣΥΝΔΕΣΜΟΥ / THRESHOLD CONNECTOR CODE: 310-15-577-00

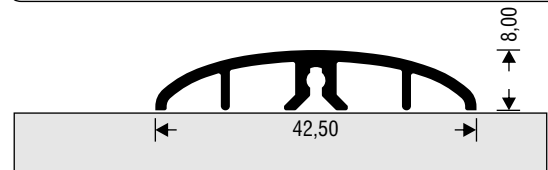

M 15195

W=568 gr/m

ΚΑΤΩΚΑΣΙ
THRESHOLD

ΚΩΔ. ΣΥΝΔΕΣΜΟΥ / THRESHOLD CONNECTOR CODE: 310-15-195-00

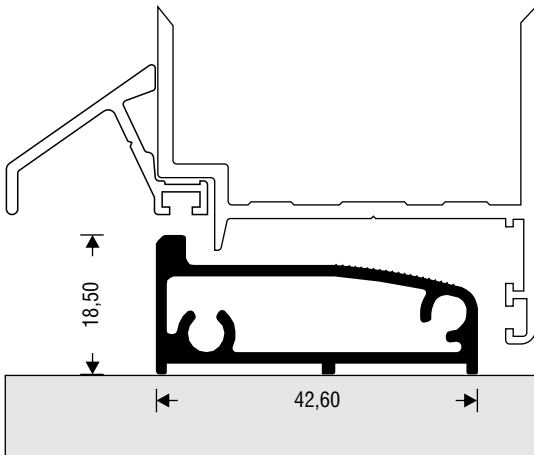

M 9316

W=136 gr/m

ΝΤΙΖΑ ΜΗΧΑΝΙΣΜΟΥ
ROD

ΚΑΛΥΠΤΕΙ ΤΟ "ΚΑΝΑΛΙ"
15 X 20 ΤΩΝ ΦΥΛΛΩΝ
CONCEALS THE 15 X 20
ROD GUIDE IN SASHES

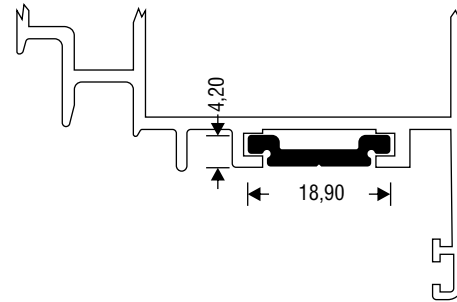

M 9351

W=70 gr/m

ΚΑΠΑΚΙ
COVER

ΚΑΛΥΠΤΕΙ ΤΟ "ΚΑΝΑΛΙ"
14 X 18 ΣΕ ΚΑΣΕΣ ΚΑΙ ΤΑΦ
CONCEALS THE 14 X 18
GLAZING BEAD SOCKET
IN FRAMES AND "T" PROFILES

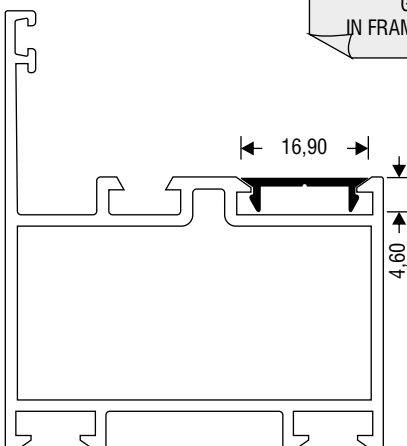

ΑΡΜΟΚΑΛΥΠΤΡΑ - DECORATIVE ARMATURES

M 15120

W=432 gr/m

ΑΡΜΟΚΑΛΥΠΤΡΟ
DECORATIVE TRIMMING

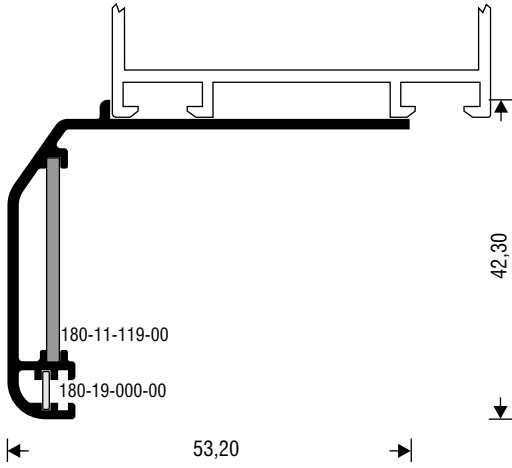

M 15119

W=481 gr/m

ΑΡΜΟΚΑΛΥΠΤΡΟ
DECORATIVE TRIMMING

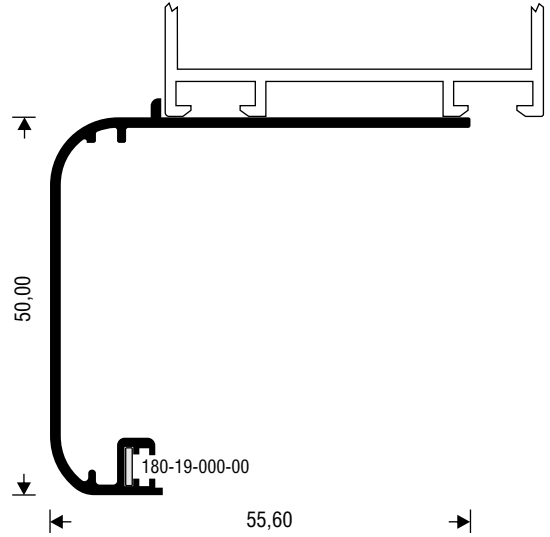

M 15118

W=465 gr/m

ΑΡΜΟΚΑΛΥΠΤΡΟ
DECORATIVE TRIMMING

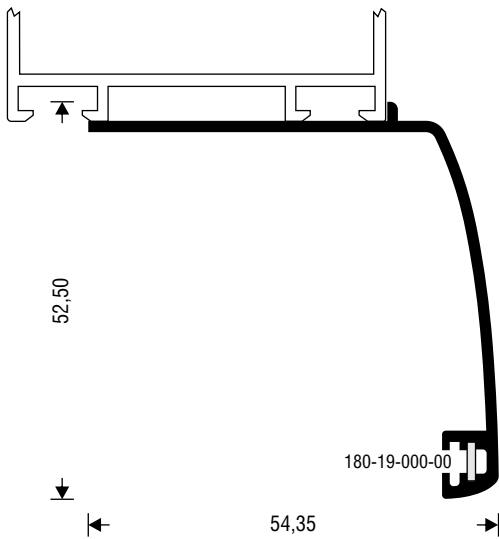

M 6000

W=503 gr/m

ΑΡΜΟΚΑΛΥΠΤΡΟ
DECORATIVE TRIMMING

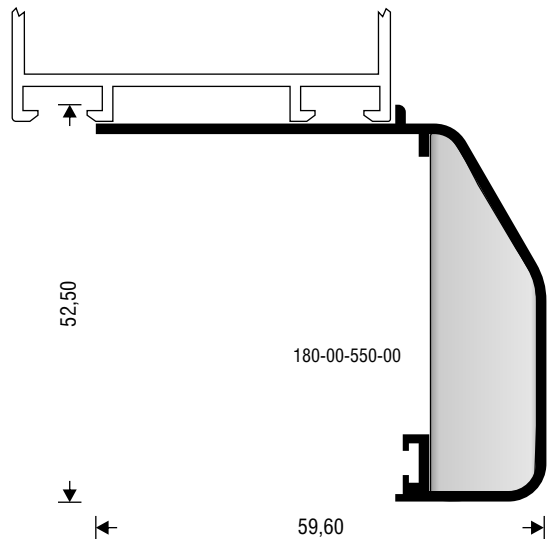

M 11118

W=324 gr/m

ΑΡΜΟΚΑΛΥΠΤΡΟ
DECORATIVE TRIMMING

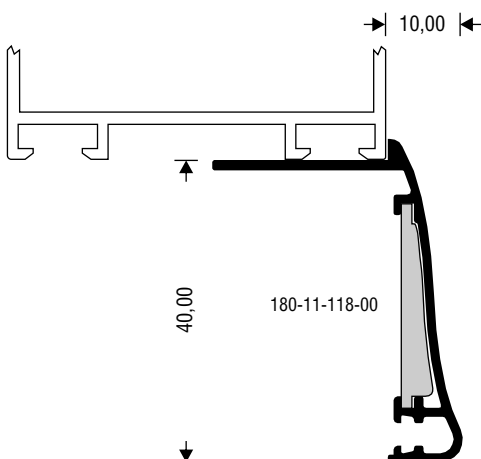

M 11119

W=379 gr/m

ΑΡΜΟΚΑΛΥΠΤΡΟ
DECORATIVE TRIMMING

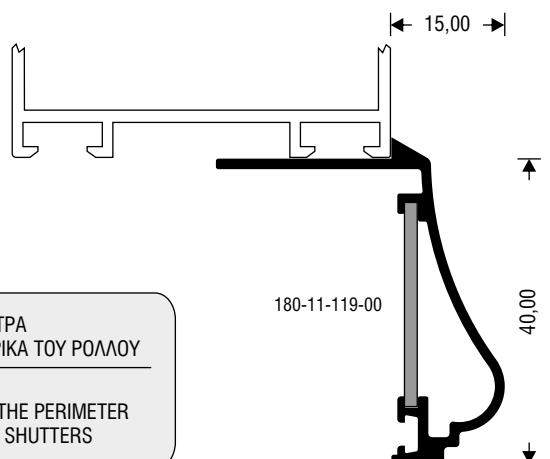

ΤΑ ΠΑΡΑΠΑΝΩ ΑΡΜΟΚΑΛΥΠΤΡΑ
"ΣΥΝΕΧΙΖΟΥΝ" ΚΑΙ ΠΕΡΙΜΕΤΡΙΚΑ ΤΟΥ ΡΟΛΛΟΥ

ILLUSTRATED ARMATURES
CAN BE ALSO INSTALLED IN THE PERIMETER
OF WINDOWS WITH ROLLING SHUTTERS

M 6039

W=197 gr/m

ΑΡΜΟΚΑΛΥΠΤΡΟ
DECORATIVE TRIMMING

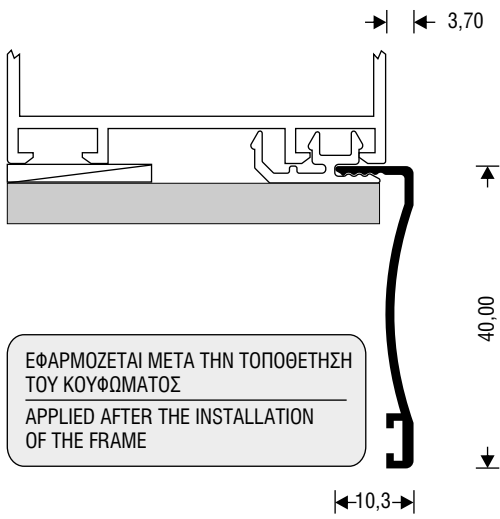

M 6040

W=115 gr/m

ΚΟΥΜΠΩΜΑ ΑΡΜΟΚΑΛΥΠΤΡΟΥ
COUPLING PROFILE

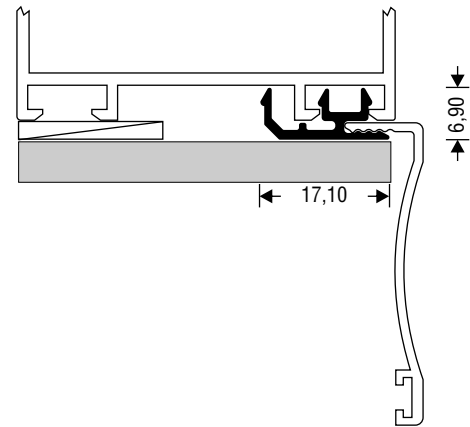

ΠΗΧΑΚΙΑ - GLAZING BEADS

M 946

W=232 gr/m

ΠΗΧΑΚΙ ΙΣΙΟ
GLAZING BEAD

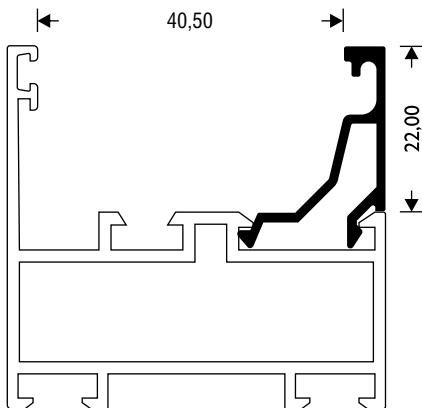

M 9313

W=175 gr/m

ΠΗΧΑΚΙ ΙΣΙΟ
GLAZING BEAD

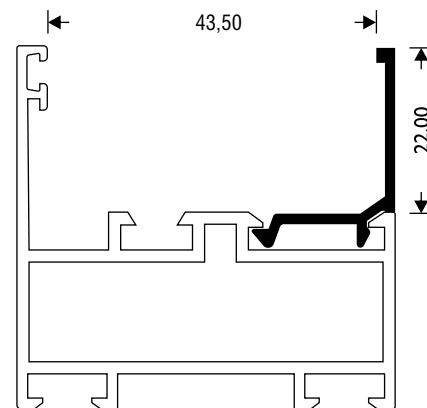

M 11451

W=307 gr/m

ΠΗΧΑΚΙ ΙΣΙΟ
GLAZING BEAD

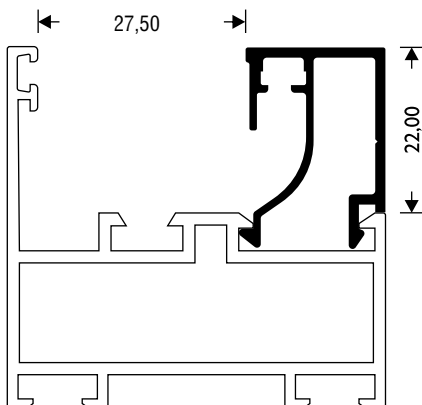

M 9312

W=242 gr/m

ΠΗΧΑΚΙ ΙΣΙΟ
GLAZING BEAD

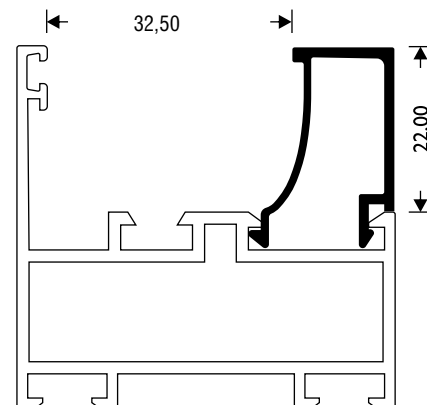

M 11452
W=314 gr/m

ΠΗΧΑΚΙ ΙΣΙΟ
GLAZING BEAD

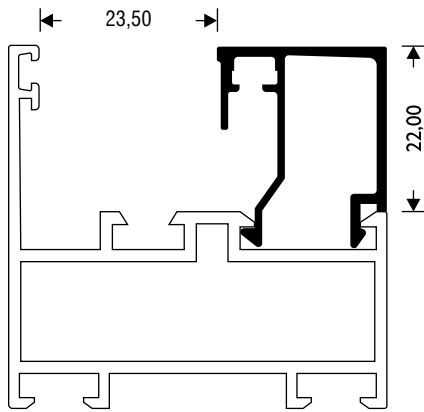

M 11453
W=325 gr/m

ΠΗΧΑΚΙ ΙΣΙΟ
GLAZING BEAD

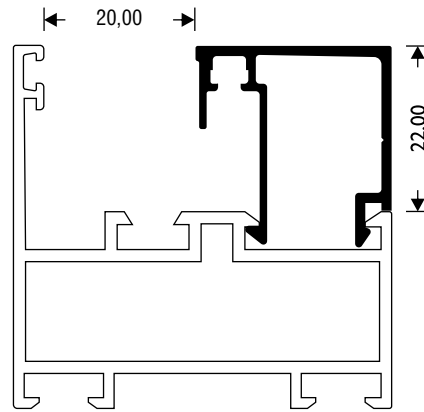

M 11454
W=351 gr/m

ΠΗΧΑΚΙ ΙΣΙΟ
GLAZING BEAD

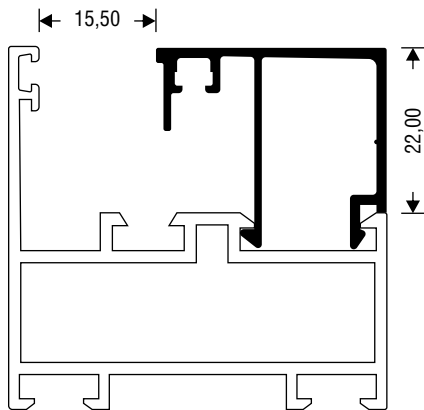

M 15110
W=364 gr/m

ΠΗΧΑΚΙ ΙΣΙΟ
GLAZING BEAD

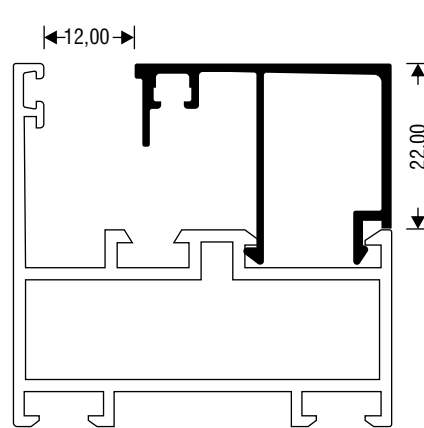

M 11462
W=298 gr/m

ΠΗΧΑΚΙ ΚΑΜΠΥΛΟ
GLAZING BEAD

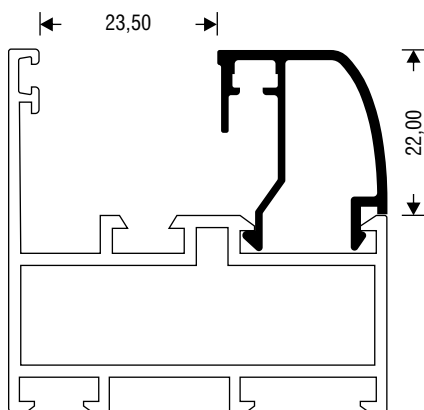

M 11463
W=313 gr/m

ΠΗΧΑΚΙ ΚΑΜΠΥΛΟ
GLAZING BEAD

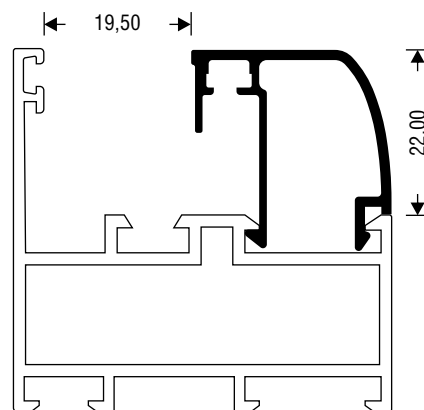

M 11464
W=332 gr/m

ΠΗΧΑΚΙ ΚΑΜΠΥΛΟ
GLAZING BEAD

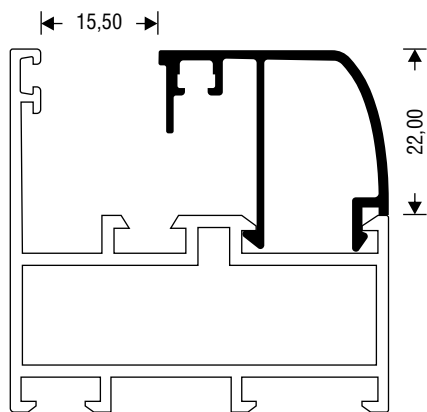

M 15174
W=188 gr/m

ΚΑΤΩΚΑΣΙ
THRESHOLD

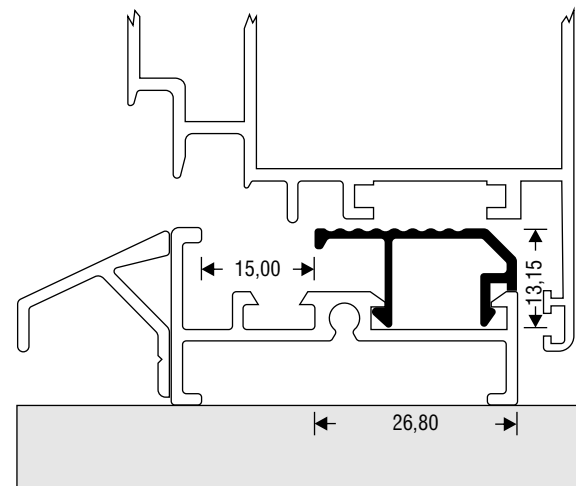

M 11226
W=228 gr/m

ΝΕΡΟΧΥΤΗΣ
DRIP PROFILE

ΚΩΔ. ΤΑΠΑΣ / PLASTIC ENDCAP CODE: 250-11-226-00

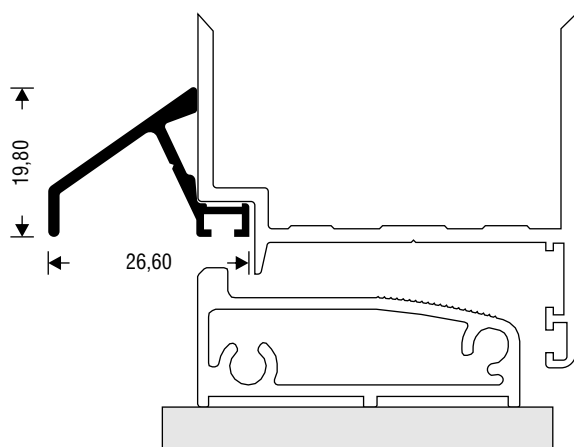

M 9317
W=181 gr/m

ΝΕΡΟΧΥΤΗΣ
DRIP PROFILE

ΚΩΔ. ΤΑΠΑΣ / PLASTIC ENDCAP CODE: 310-09-317-00

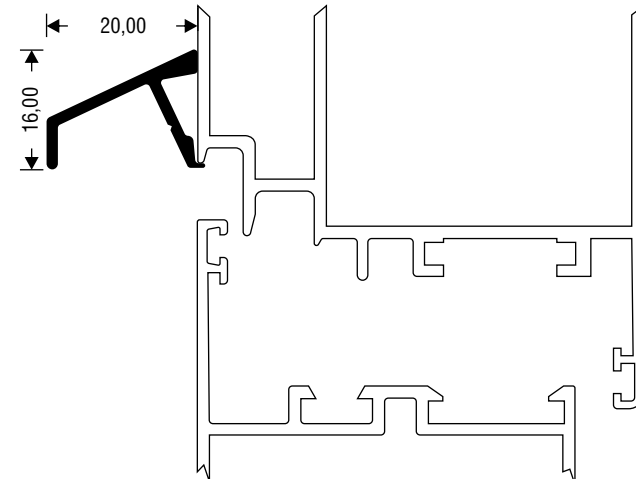

M 11116

W=184 gr/m

ΝΕΡΟΧΥΤΗΣ
DRIP PROFILE

ΚΩΔ. ΤΑΠΑΣ / PLASTIC ENDCAP CODE: 310-11-116-00

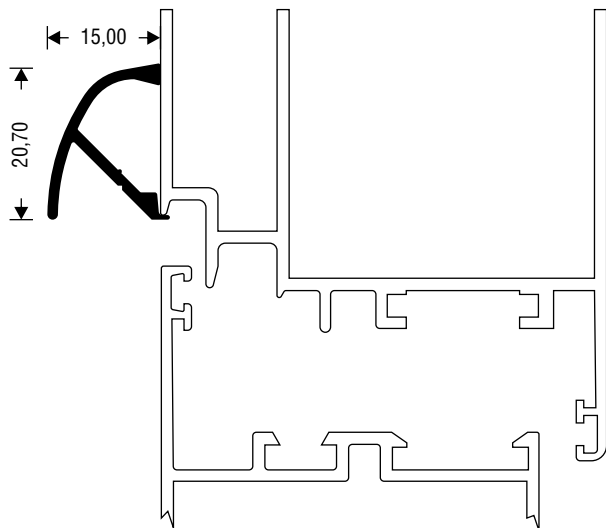

M 15117

W=205 gr/m

ΝΕΡΟΧΥΤΗΣ
DRIP PROFILE

ΚΩΔ. ΤΑΠΑΣ / PLASTIC ENDCAP CODE: 310-09-317-00

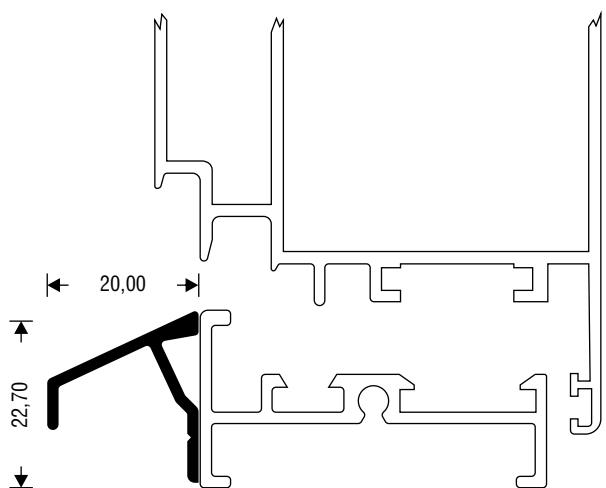

**Τυπολογία
Typology**

ΠΑΡΑΘΥΡΑ - WINDOWS

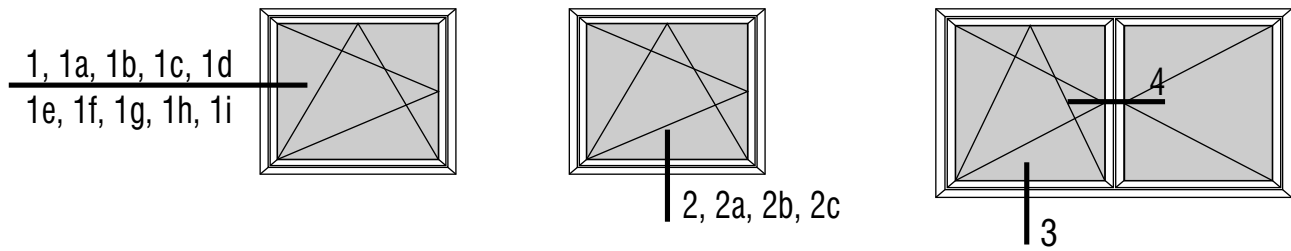

ΠΑΡΑΘΥΡΑ ΜΕ “ΚΡΥΦΟ” ΦΥΛΛΟ CONCEALED SASH WINDOWS

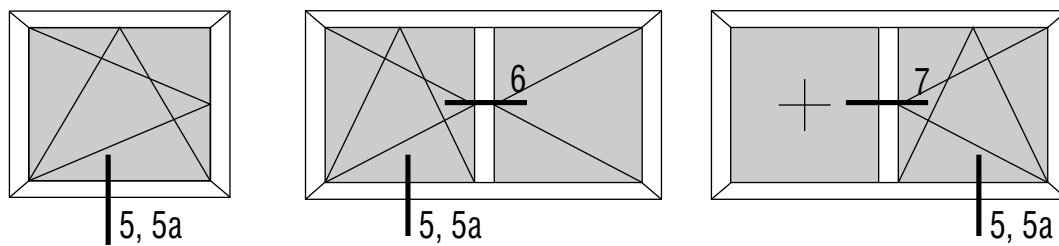

ΠΕΡΙΣΤΡΕΦΟΜΕΝΟ ΠΑΡΑΘΥΡΟ - PIVOTING WINDOW

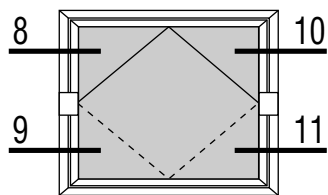

ΜΠΑΛΚΟΝΟΠΟΡΤΕΣ - BALCONY DOORS

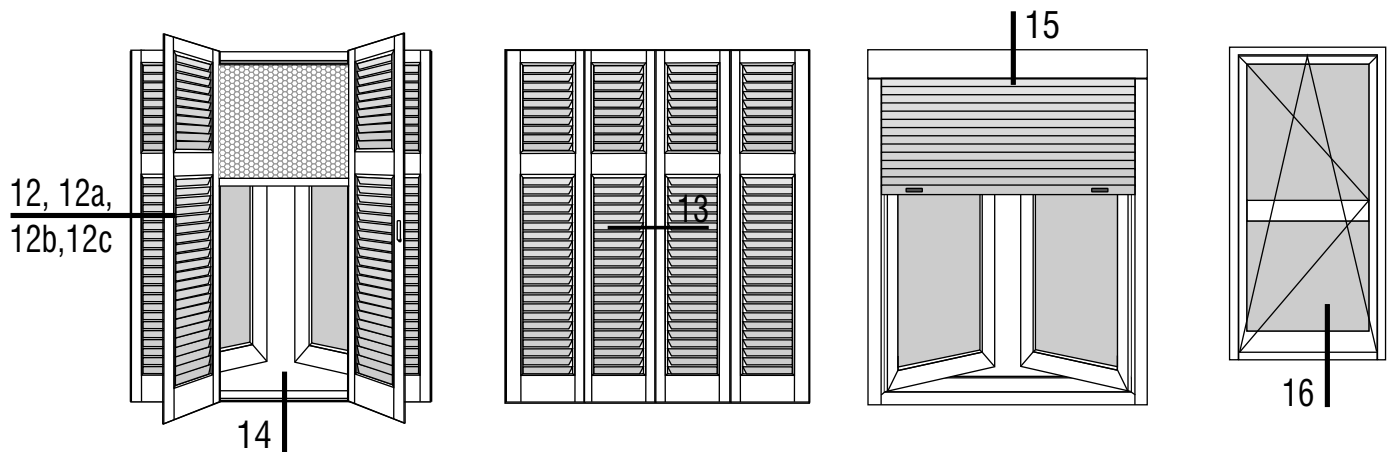

ΕΙΣΟΔΟΙ - ENTRANCE DOORS

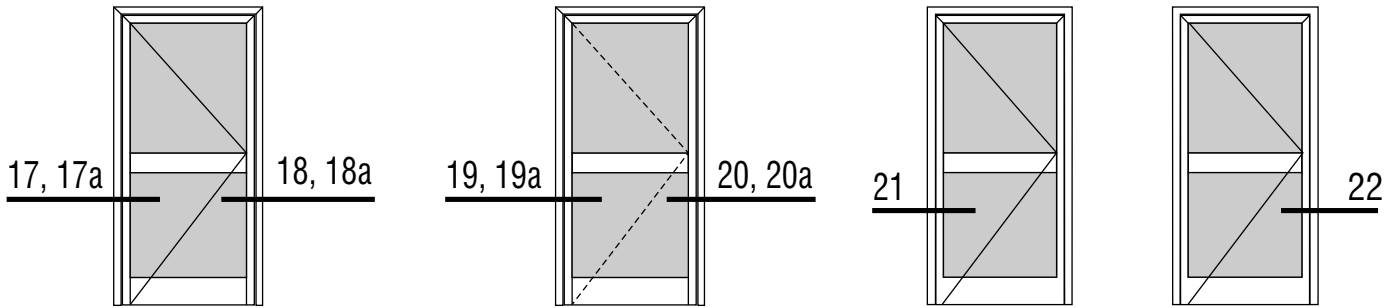

ΕΙΣΟΔΟΙ "ΑΛΕ - ΡΕΤΟΥΡ" / ENTRANCE FOR DOUBLE SWINGING DOORS

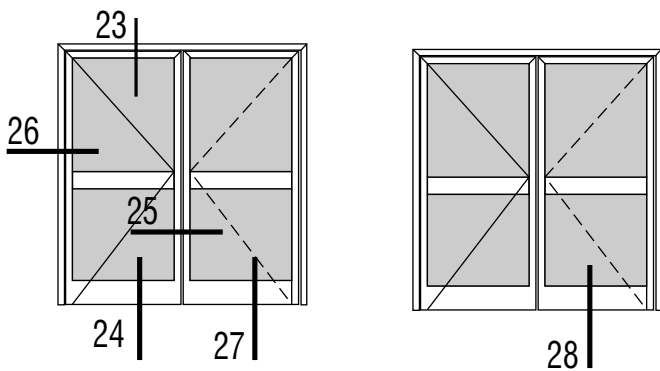

ΕΙΣΟΔΟΙ ΜΕ ΒΙΤΡΙΝΕΣ / ENTRANCE FOR STORE FRONTS

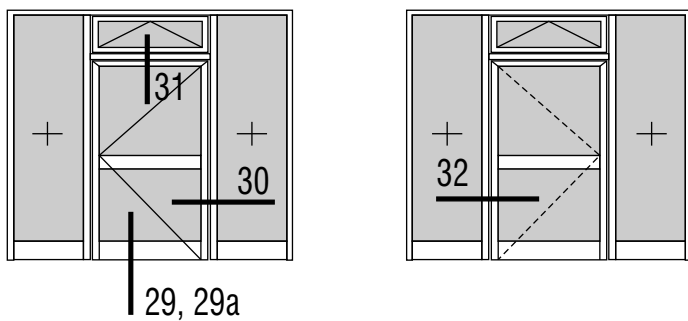

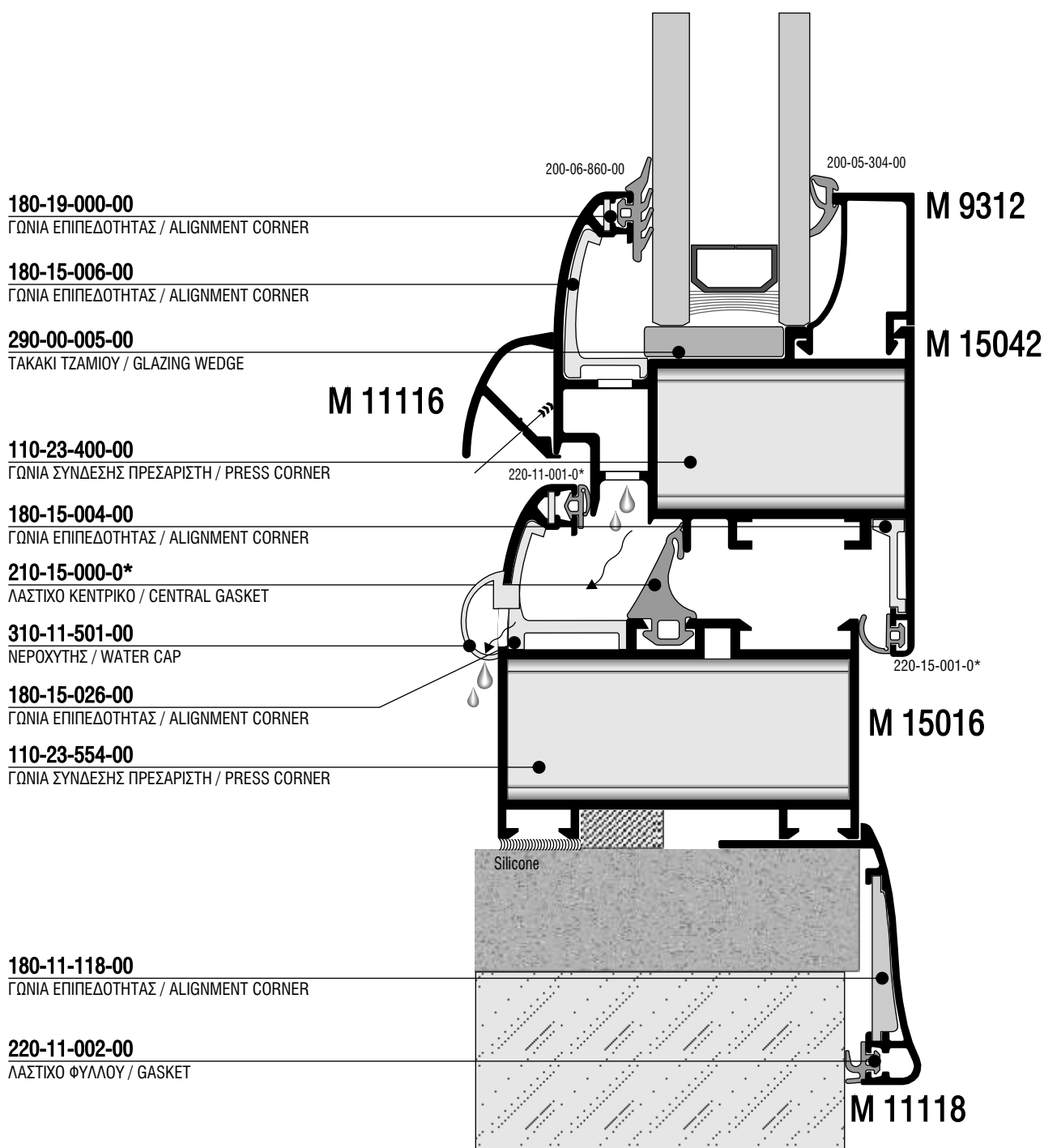
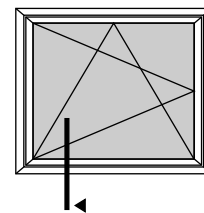

ΠΑΡΑΘΥΡΑ - WINDOWS

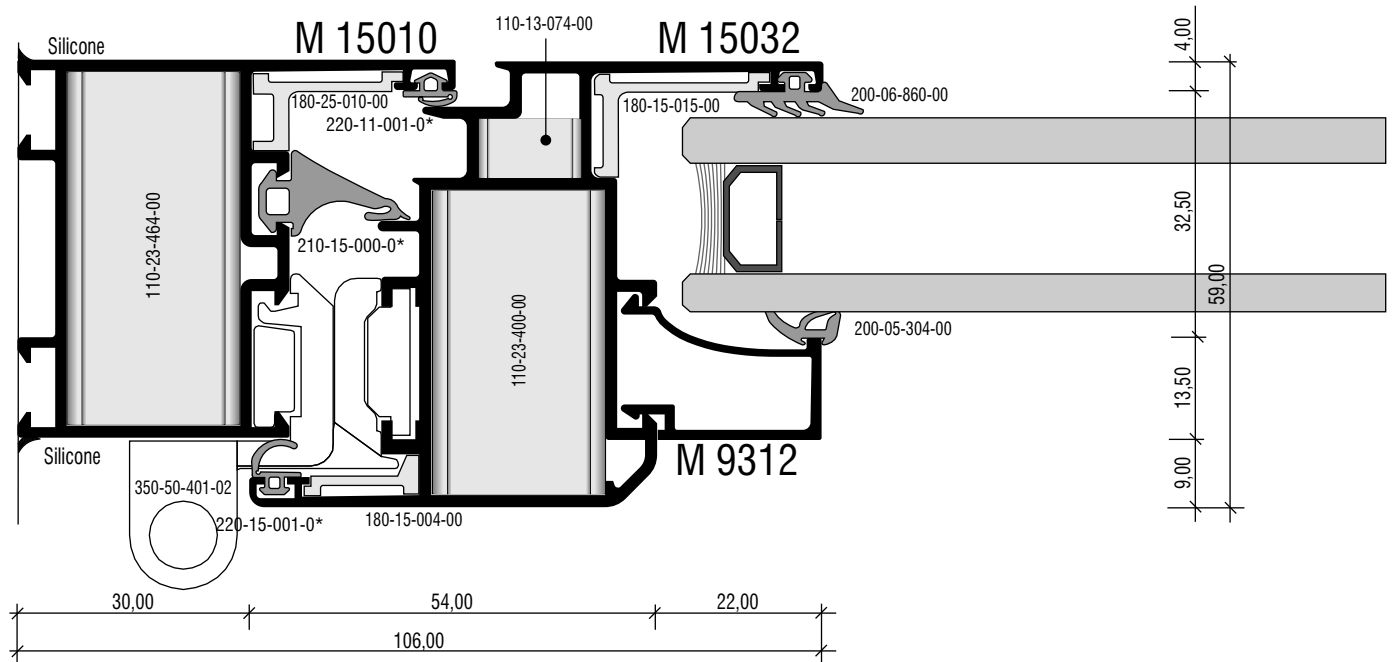
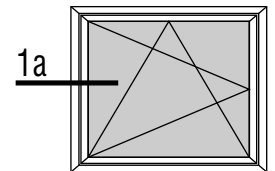
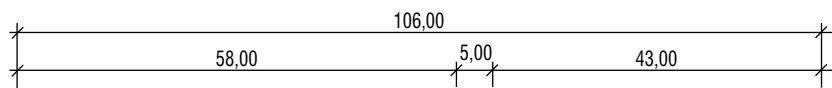
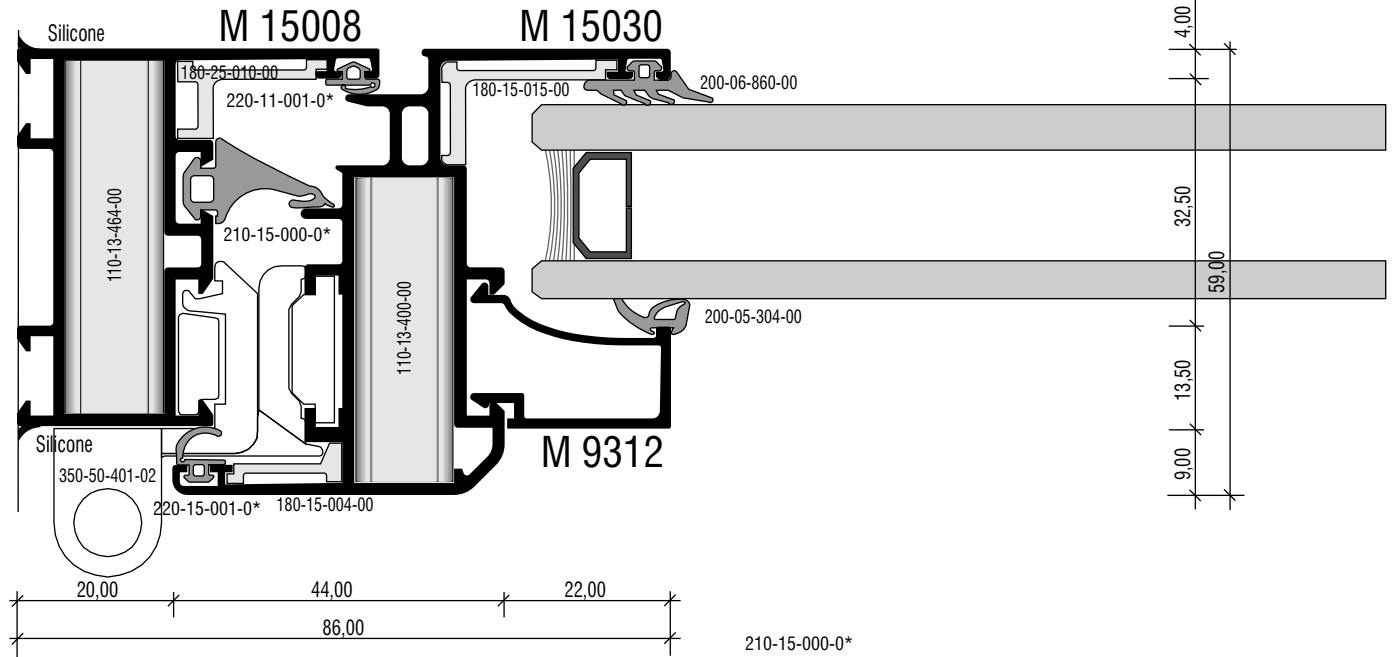
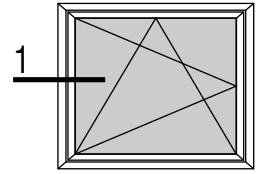
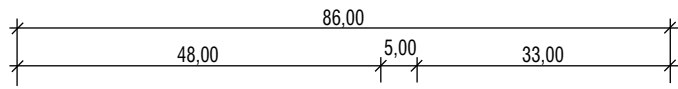

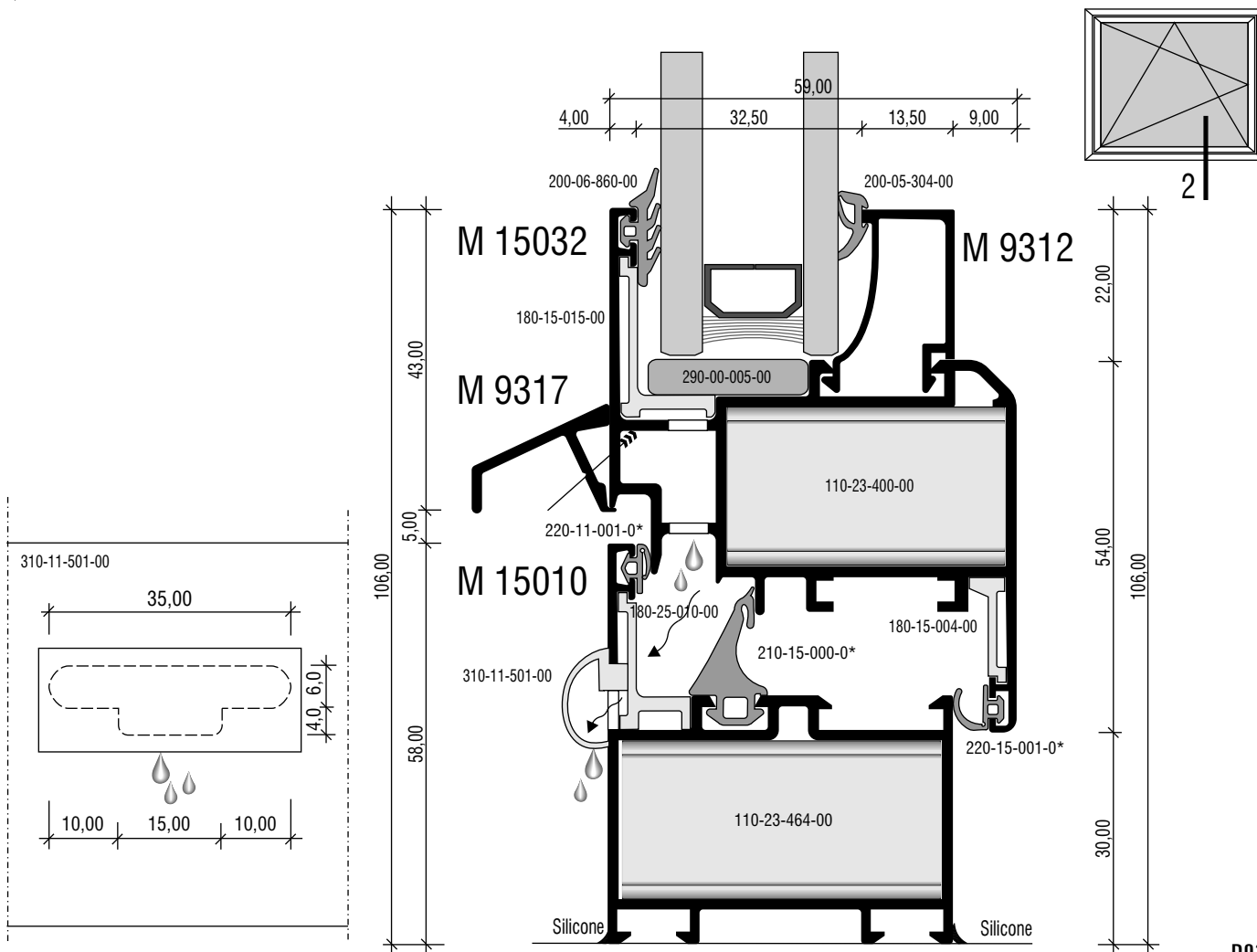
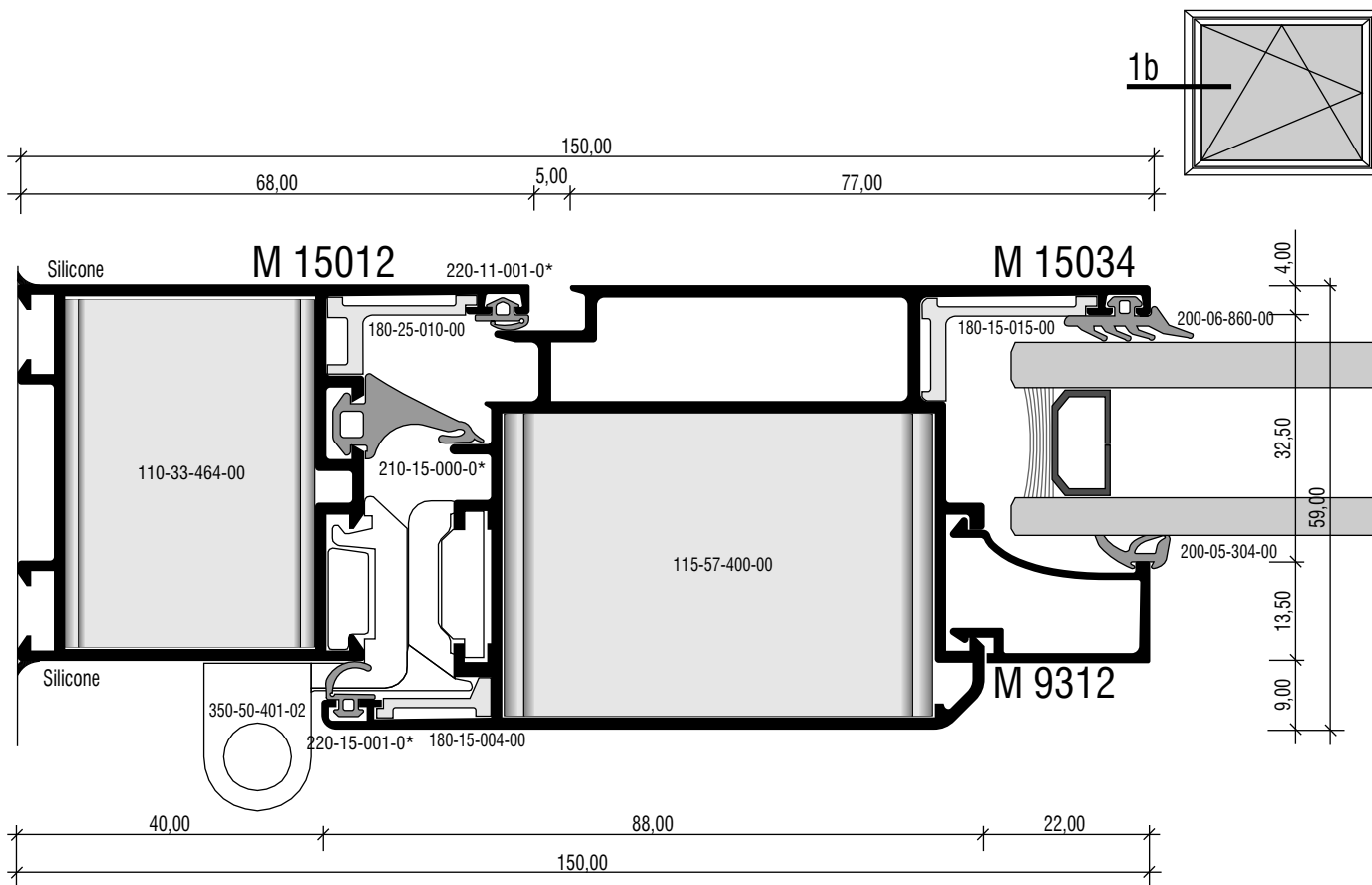

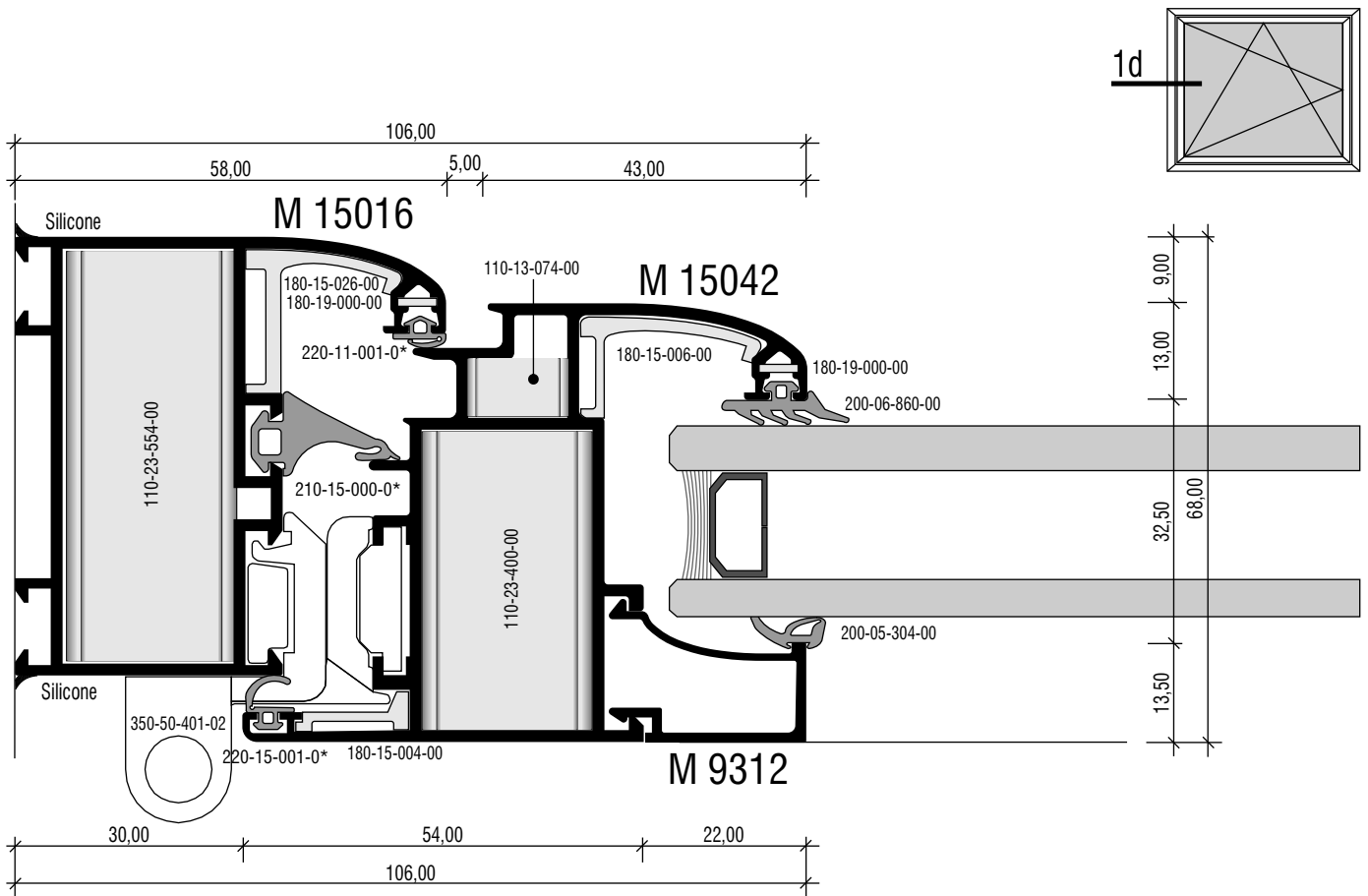
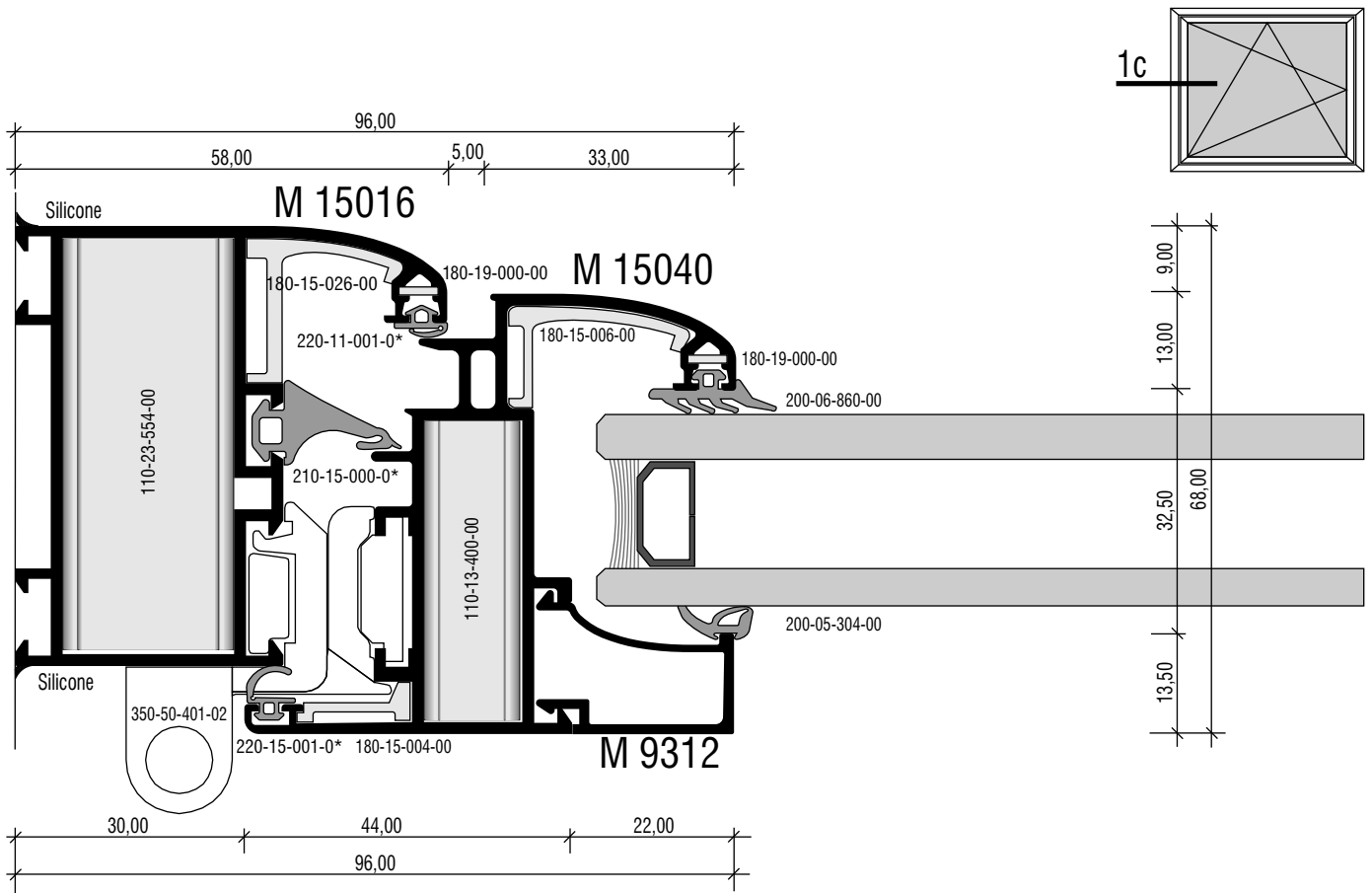

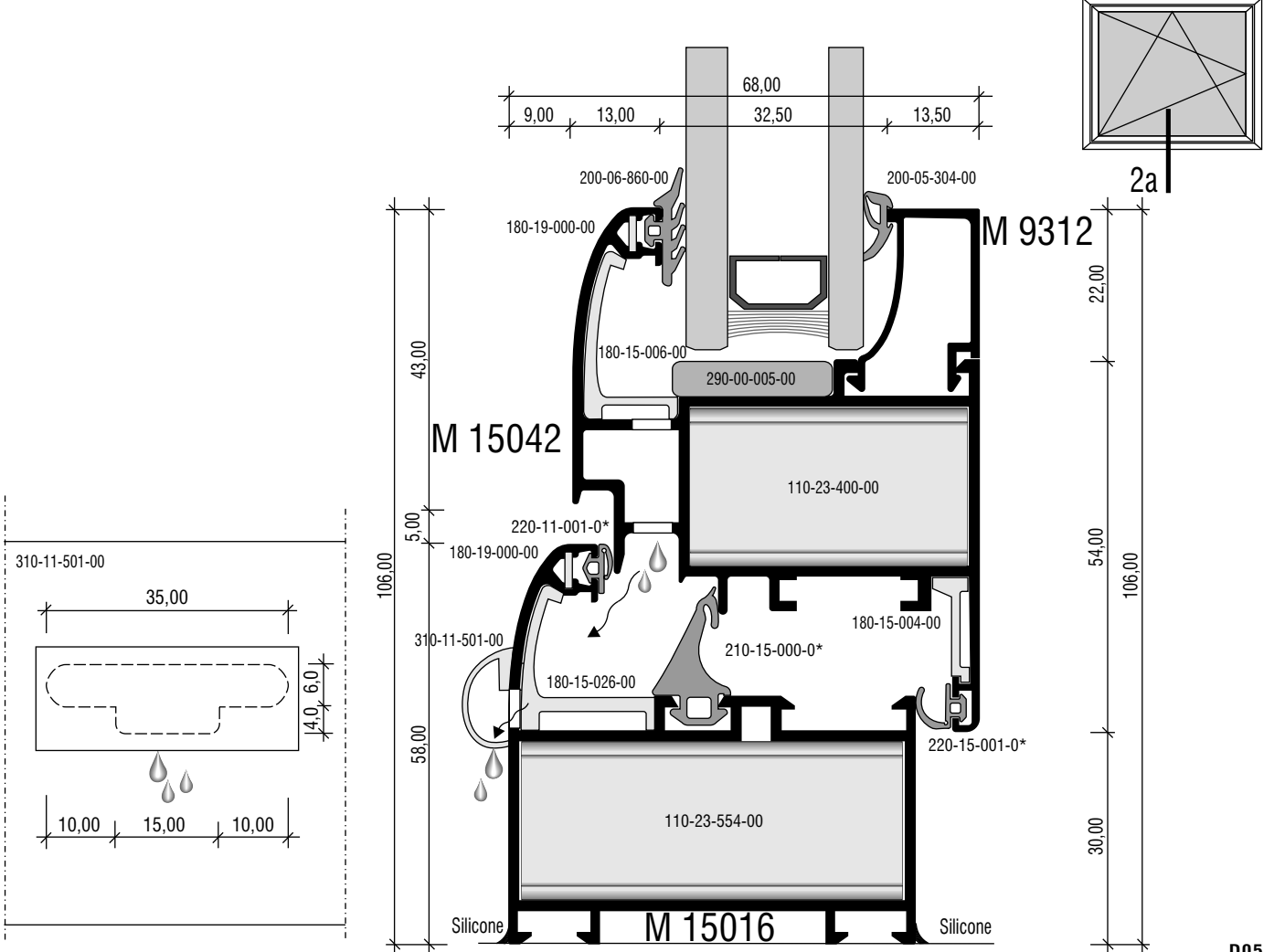
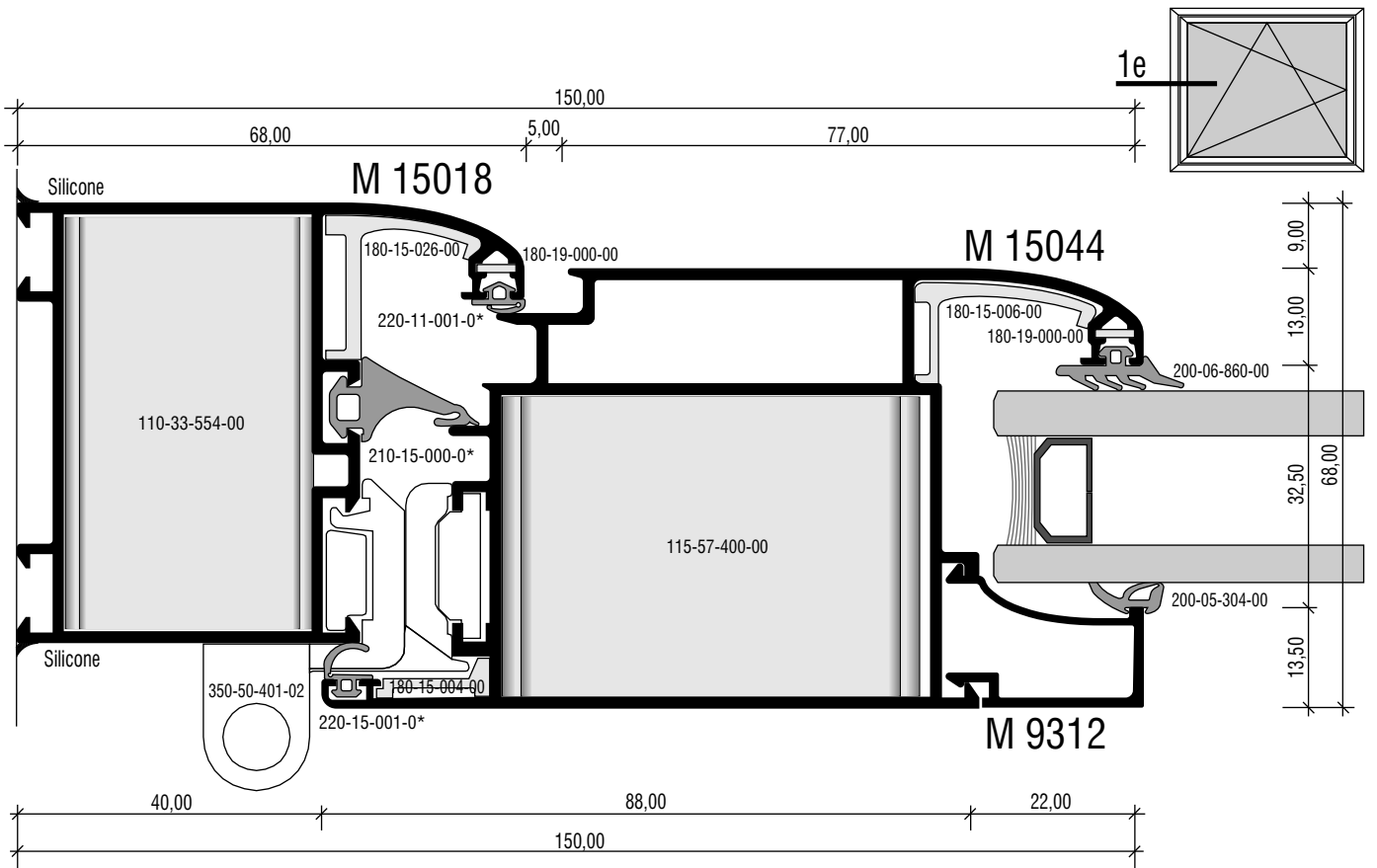

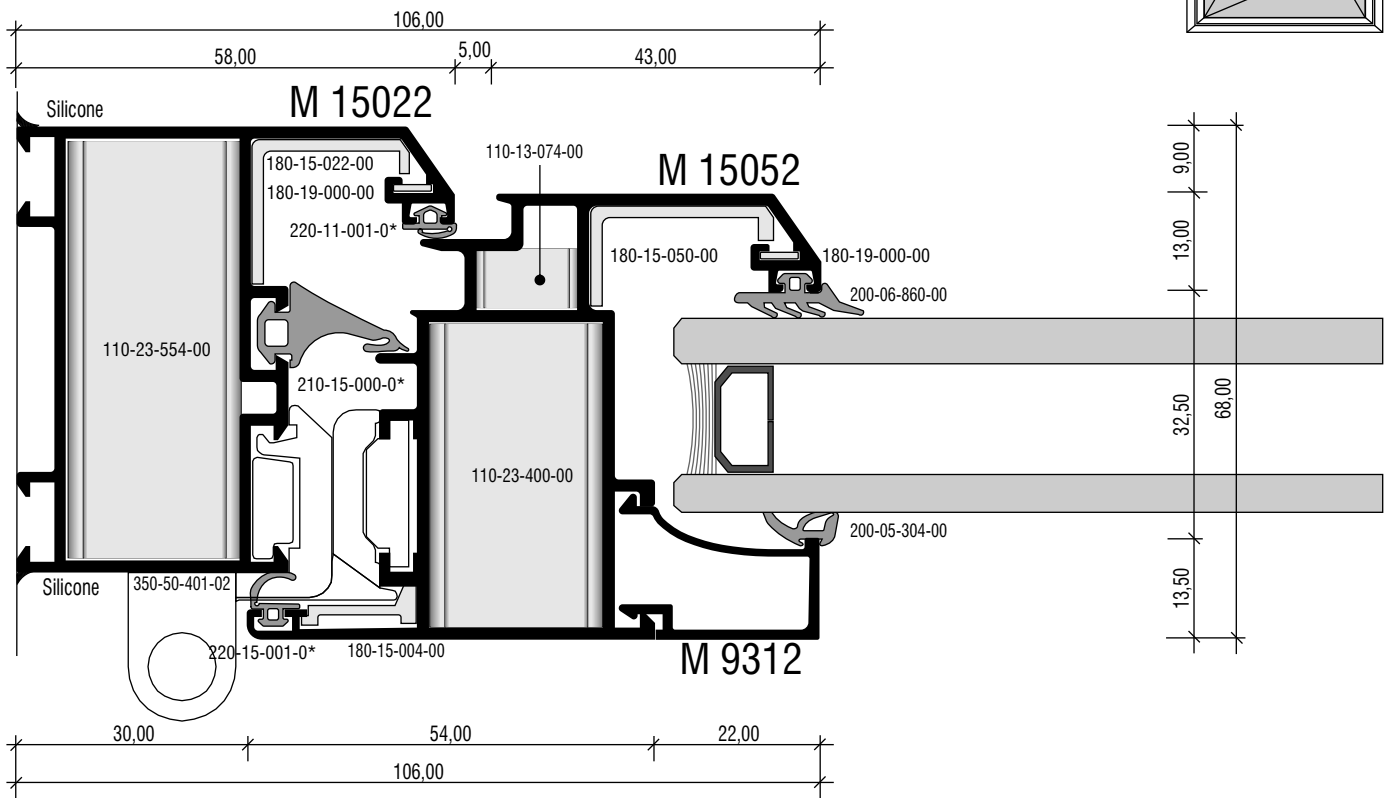
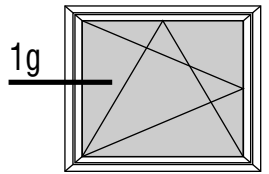
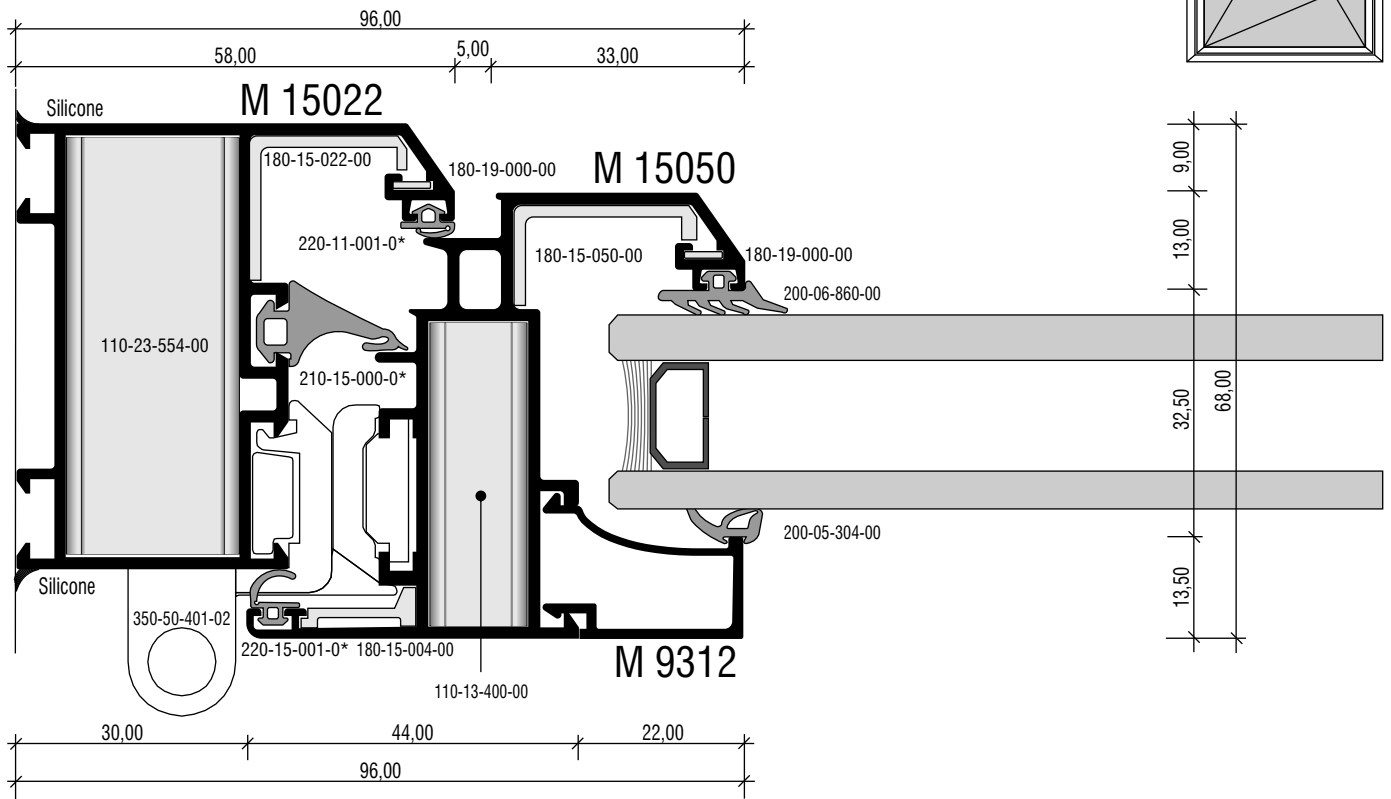
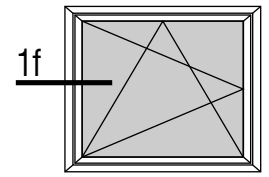

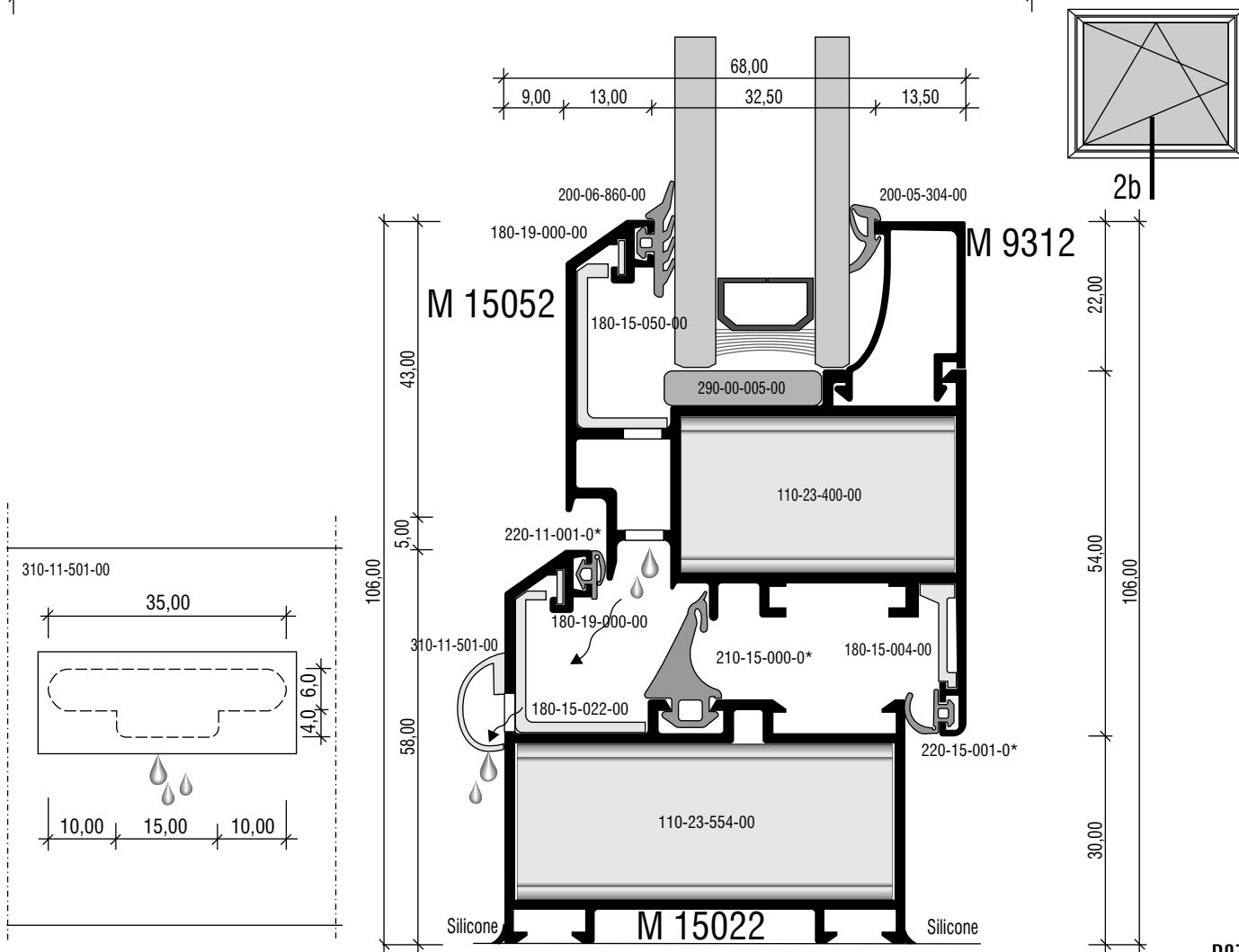
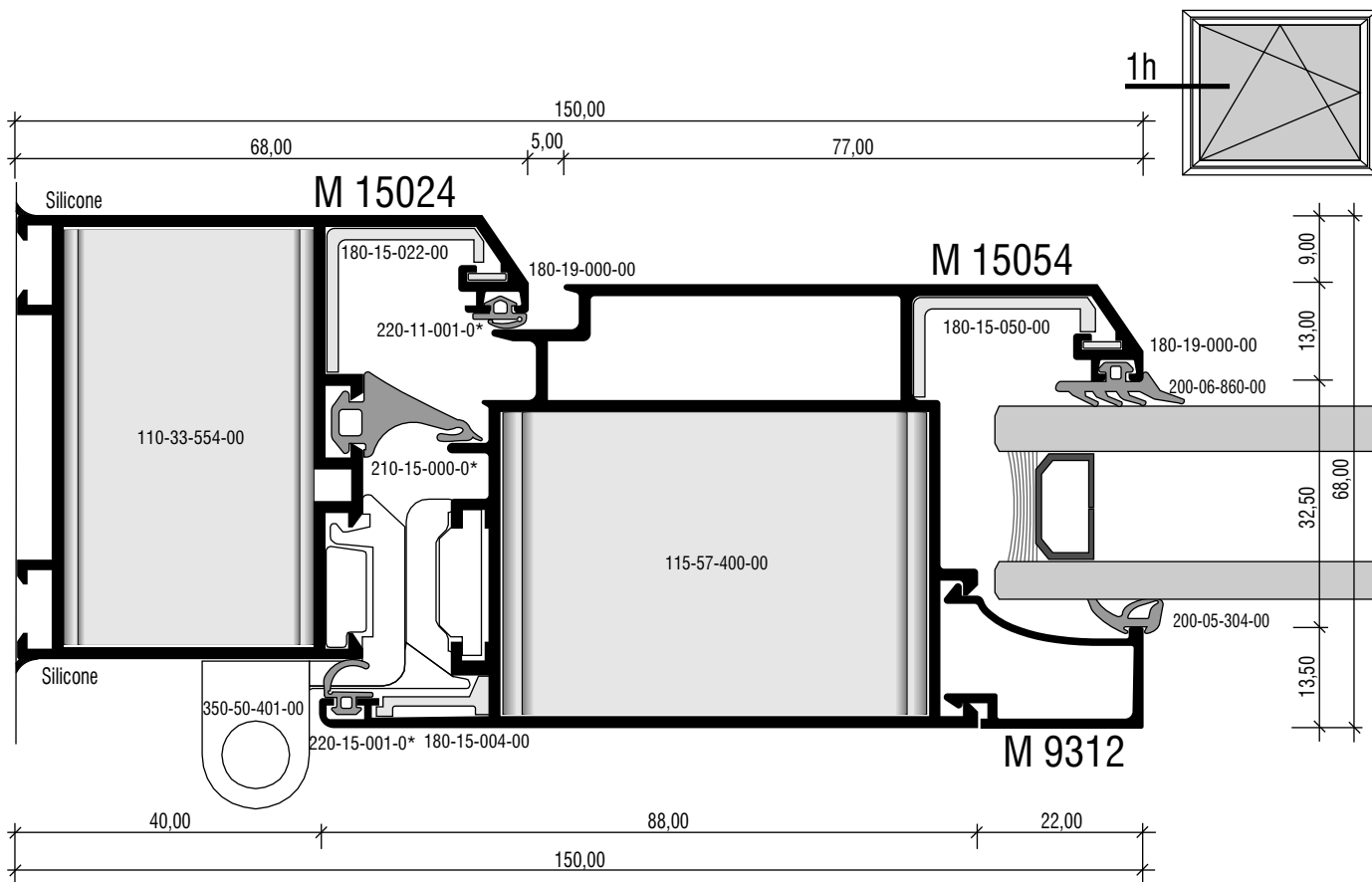

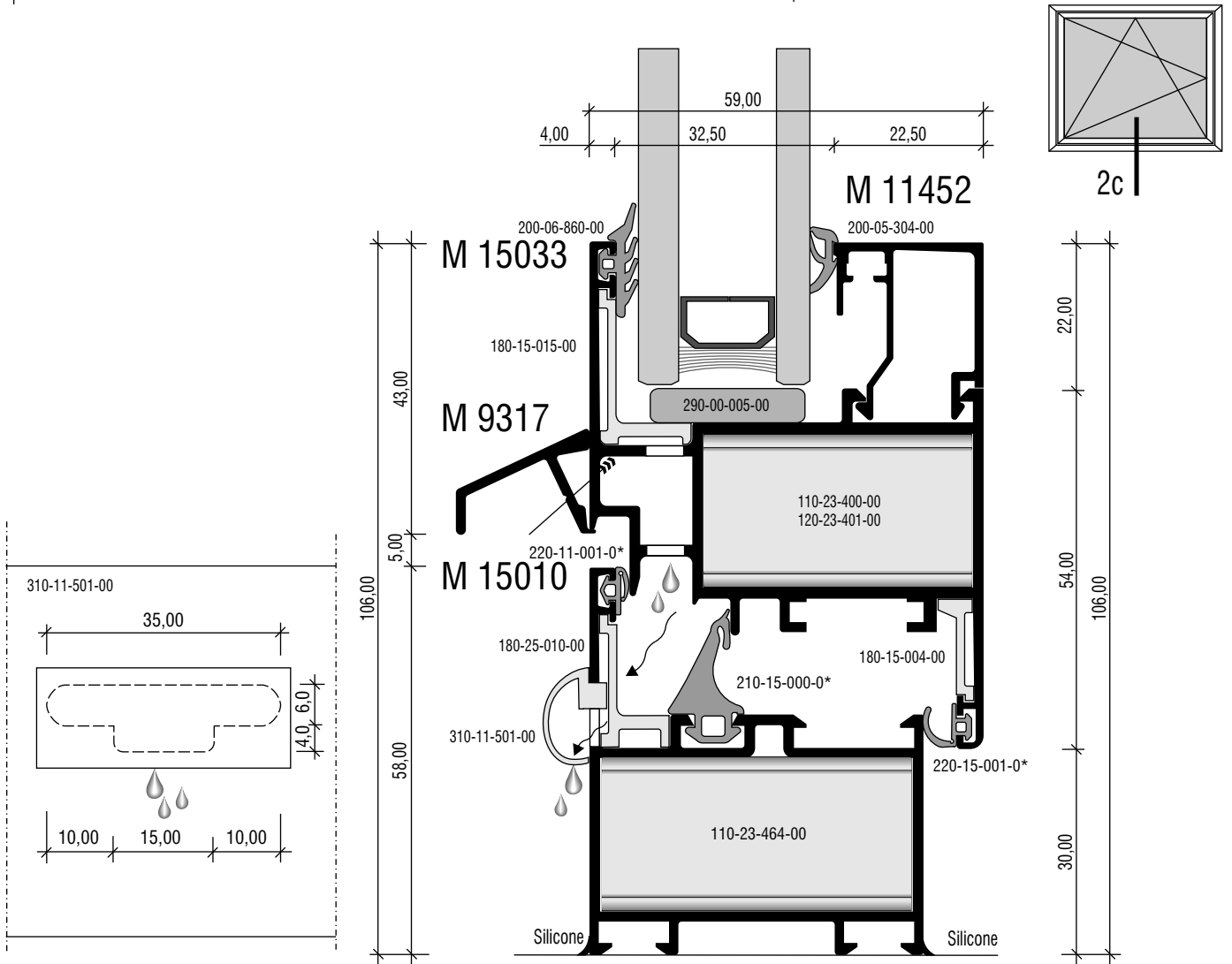
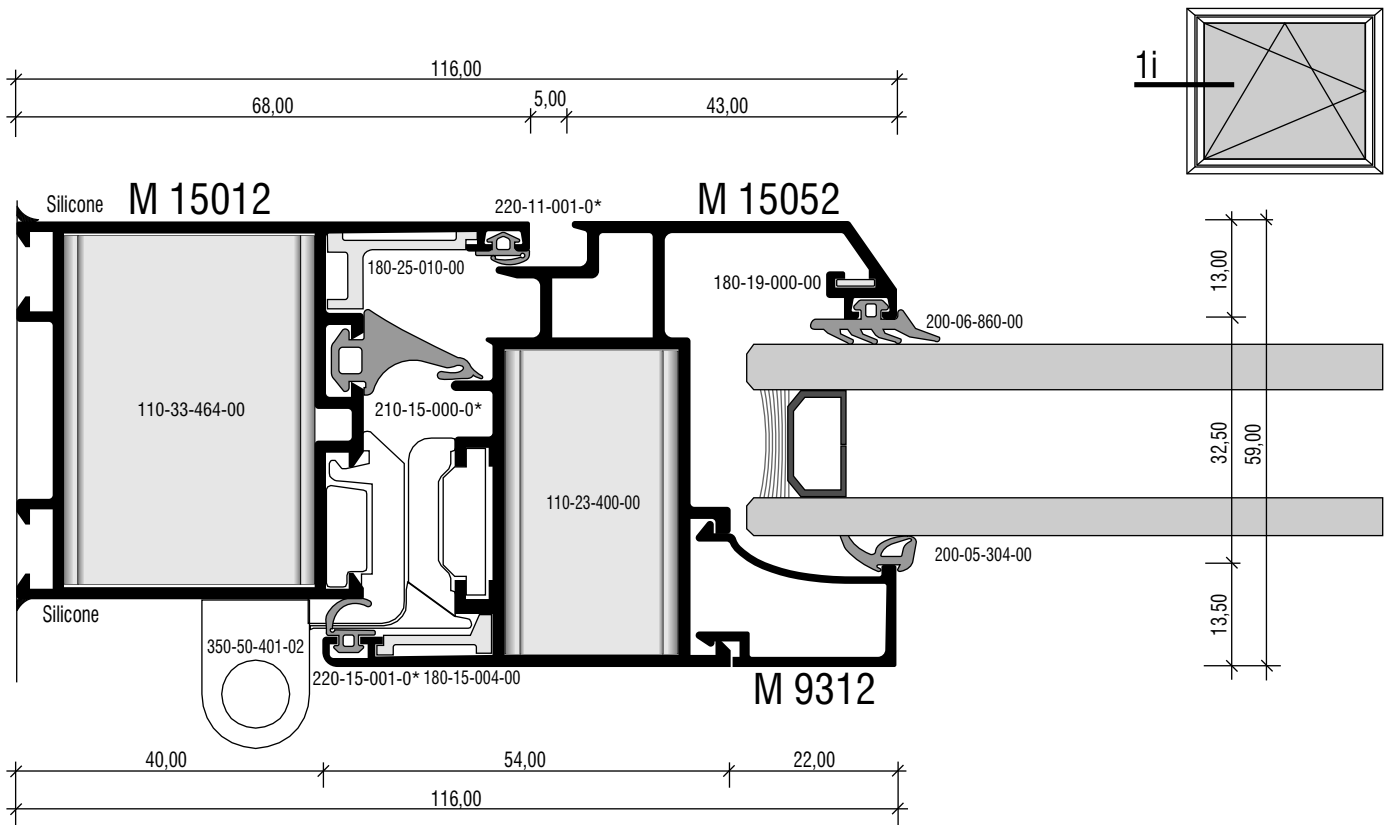

ΠΑΡΑΘΥΡΑ ΜΕ ΠΕΡΙΜΕΤΡΙΚΟΥΣ ΜΗΧΑΝΙΣΜΟΥΣ WINDOWS WITH "SCREW - ON" MECHANISMS G.U. / ROTO

ΠΡΟΣΟΧΗ: "ΓΩΝΙΑΚΗ" ΠΛΕΥΡΑ ΓΙΑ ΜΕΝΤΕΣΕ G.U.
"ΟΒΑΛ" ΠΛΕΥΡΑ ΓΙΑ ΜΕΝΤΕΣΕ ROTO

CAUTION: CORNER ENDING SUPPORTS G.U. HINGES
CIRCULAR ENDING SUPPORTS ROTO HINGES

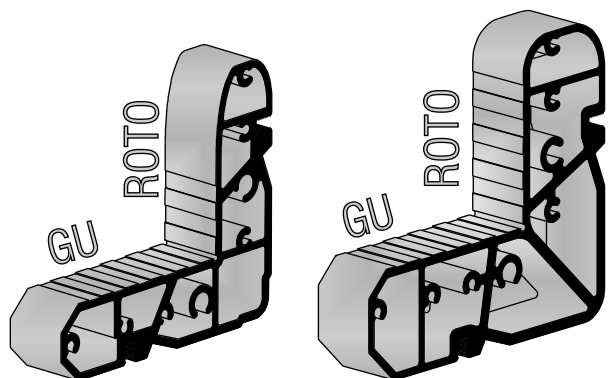
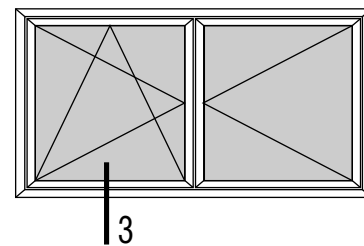

111-23-464-00
112-23-554-00

111-33-464-00
112-33-554-00

ΠΡΟΣΟΧΗ:
ΓΙΑ ΠΑΡΑΘΥΡΑ ΜΕ ΠΕΡΙΜΕΤΡΙΚΟ ΜΗΧΑΝΙΣΜΟ
ΧΡΗΣΙΜΟΠΟΙΟΥΝΤΑΙ ΜΟΝΟ ΟΙ ΚΑΞΕΣ
ΜΕ ΣΥΝΟΛΙΚΟ ΥΨΟΣ 58 Ή 68 mm.

CAUTION:
FOR WINDOWS WITH "SCREW - ON"
MECHANISM, USE FRAMES WITH
A TOTAL HEIGHT OF 58 OR 68 mm

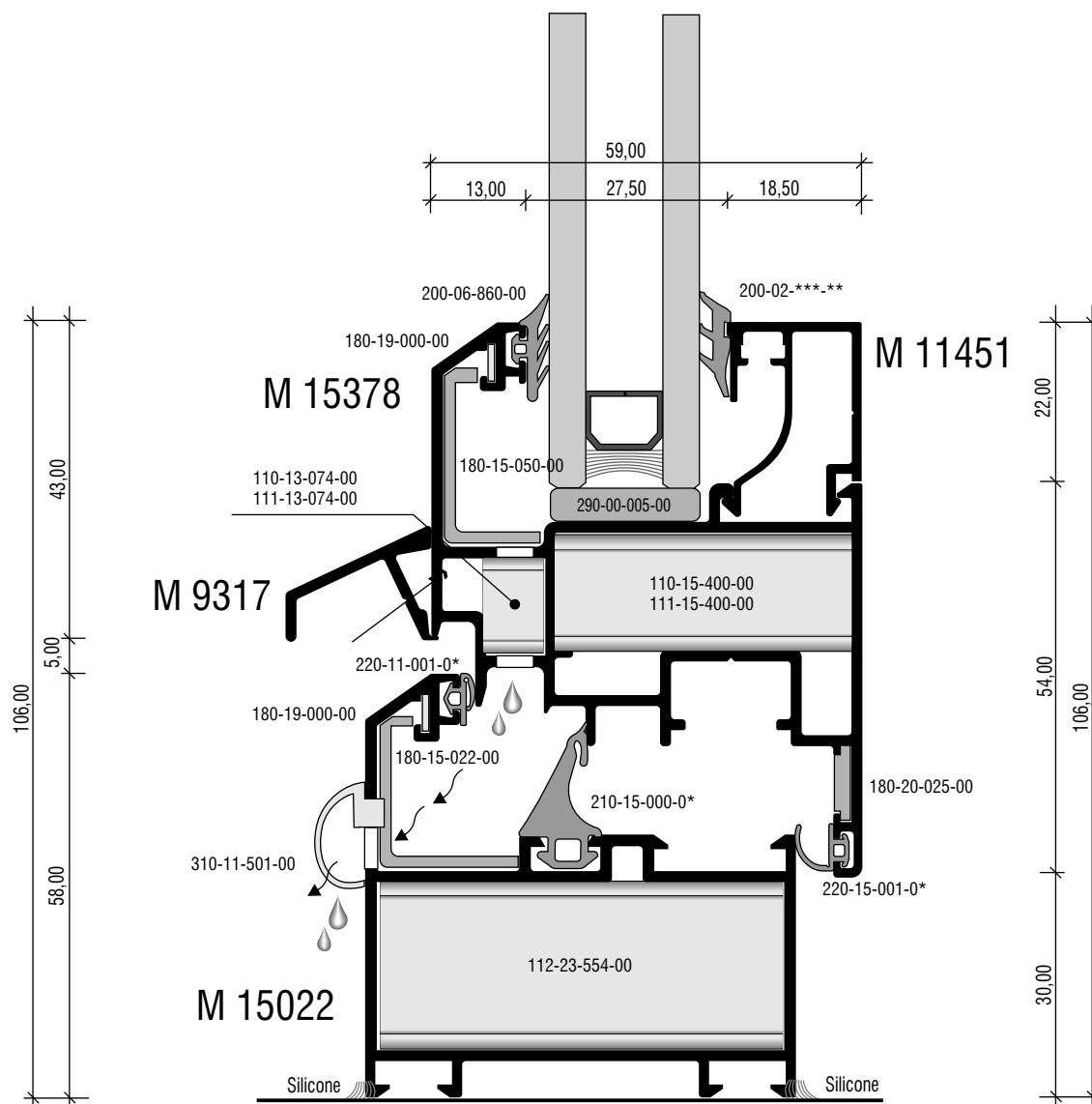

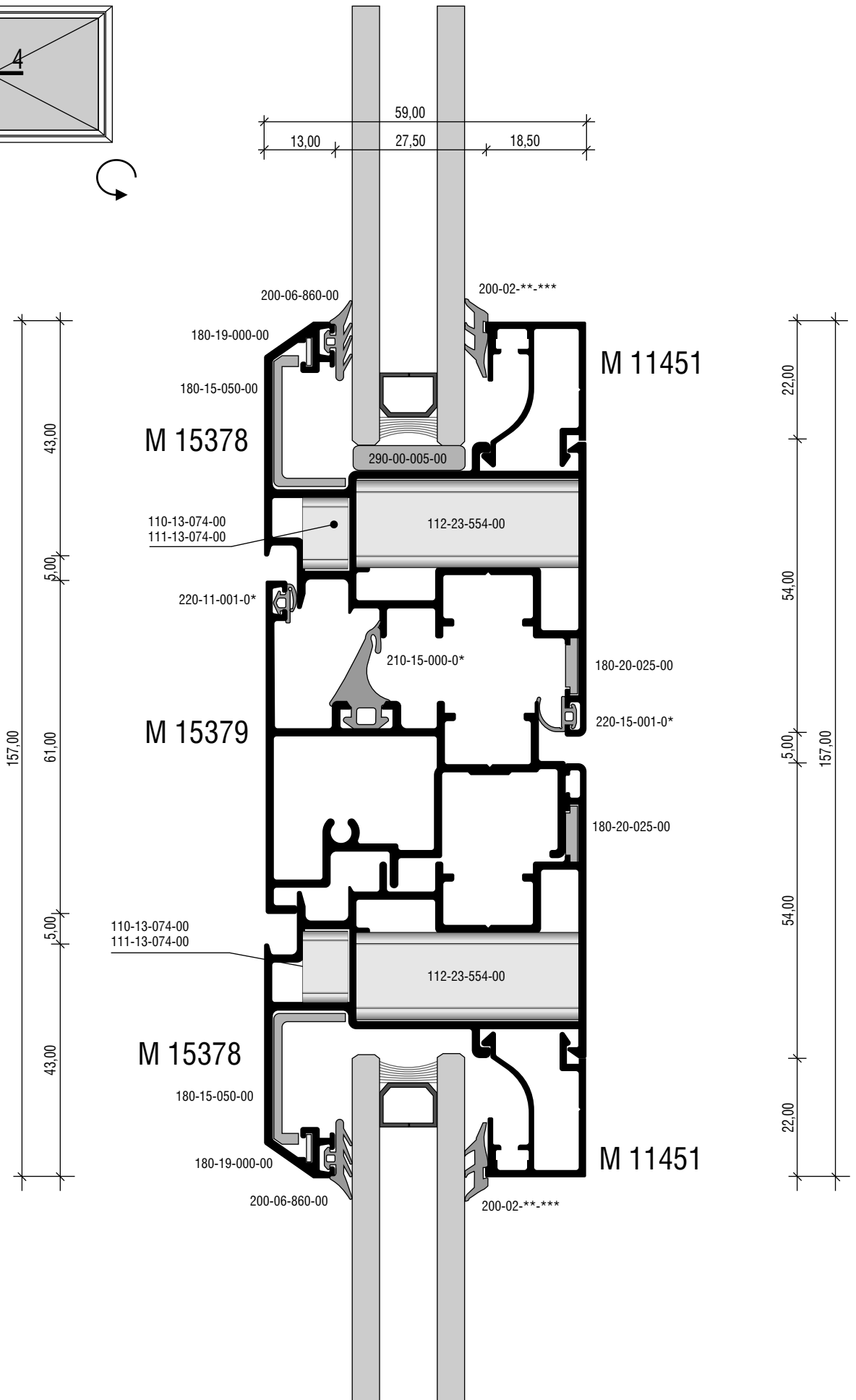
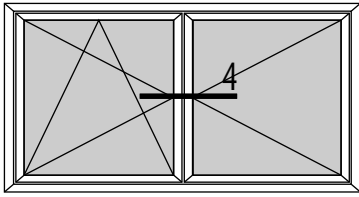

ΠΑΡΑΘΥΡΑ ΜΕ "ΚΡΥΦΟ" ΦΥΛΛΟ CONCEALED SASH WINDOWS

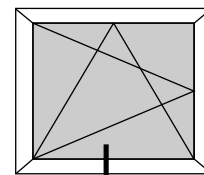

5

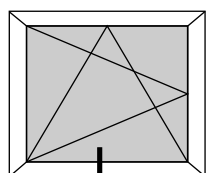

5a

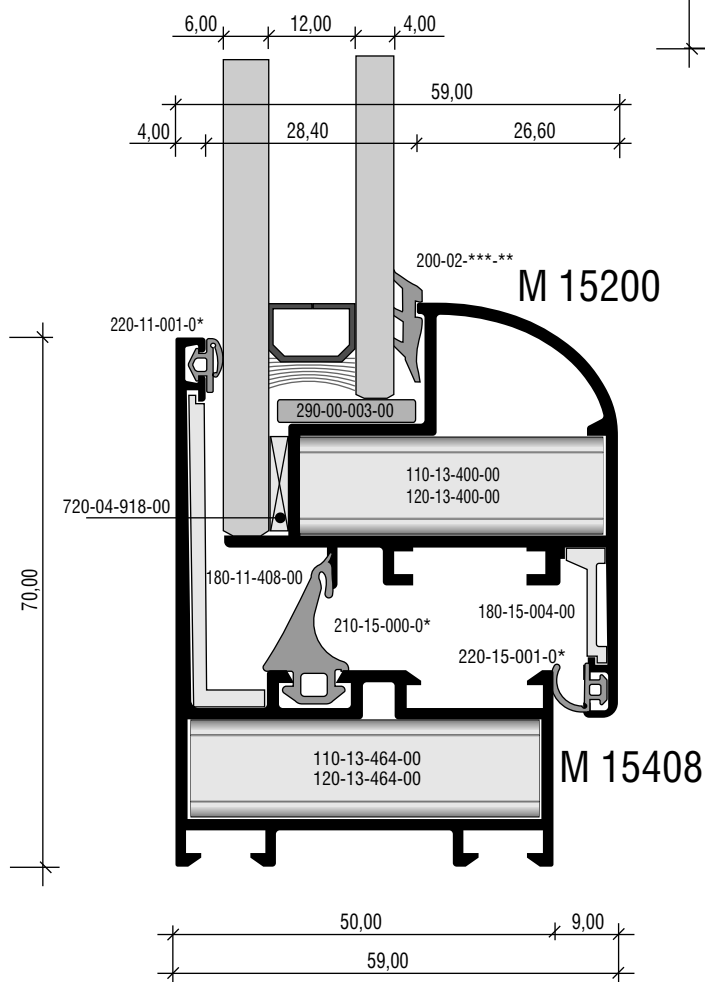
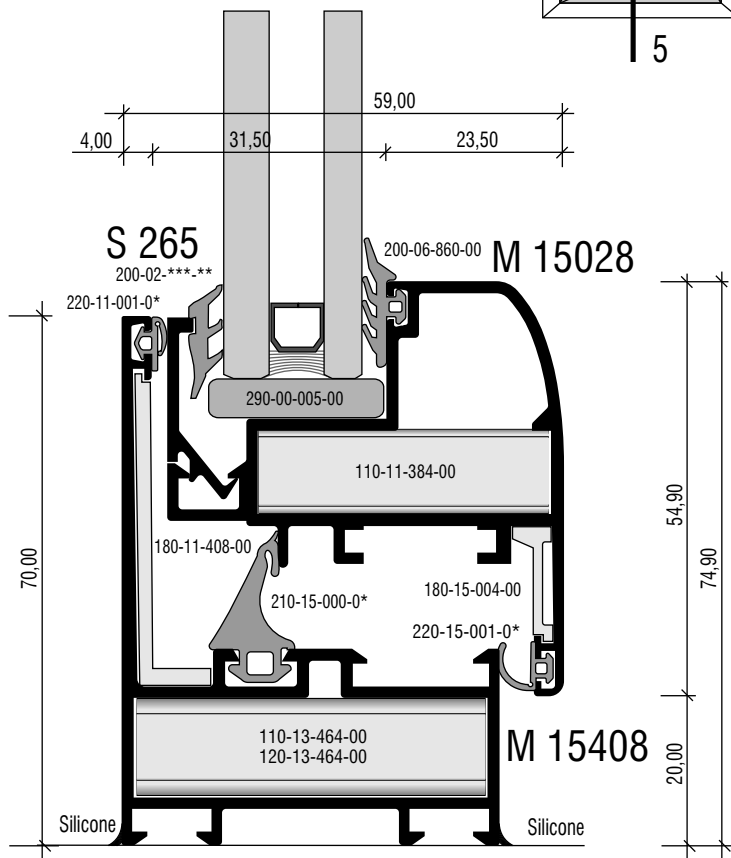

ΠΡΟΣΟΧΗ:
ΜΟΝΟ ΜΟΝΟΦΥΛΛΑ
ΚΑΙ ΓΙΑ ΕΞΩΤΕΡΙΚΟ ΤΖΑΜΙ 6mm
CAUTION:
ONLY SINGLE SASH WINDOWS

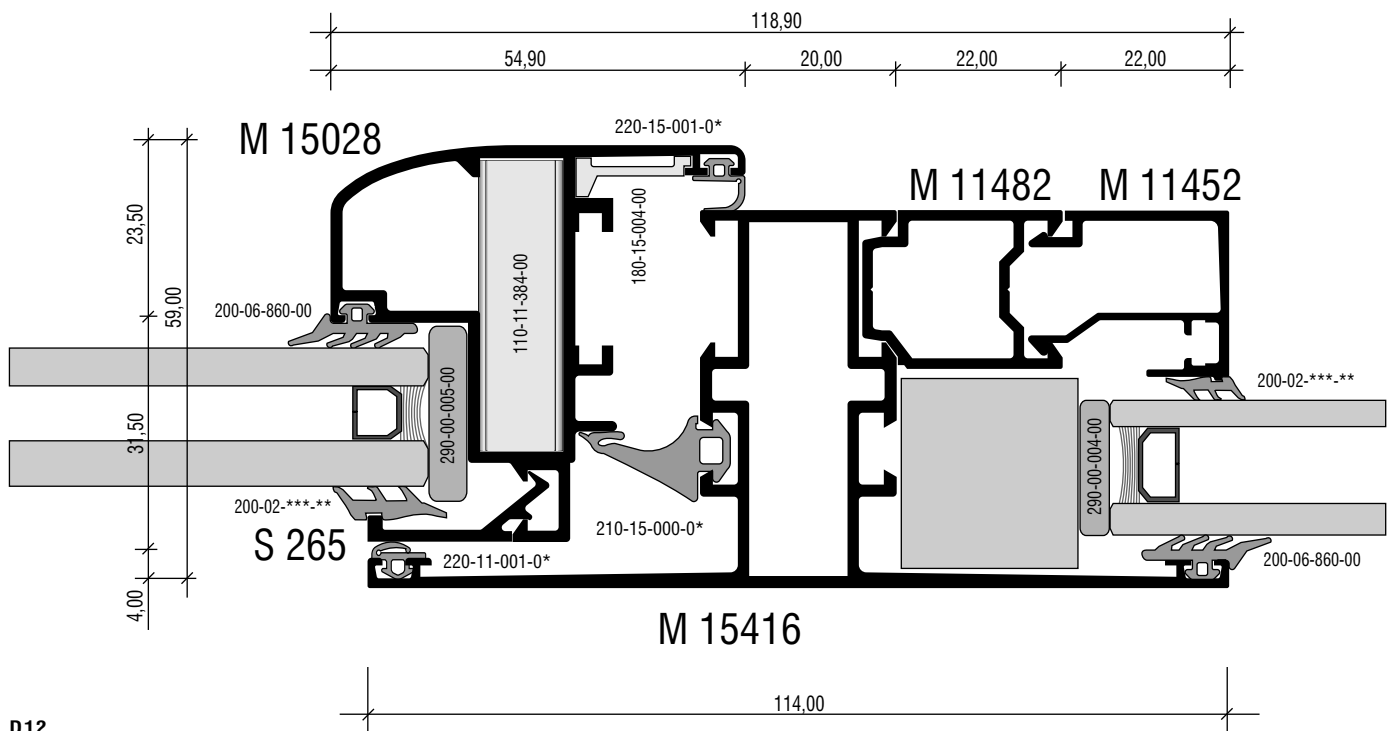
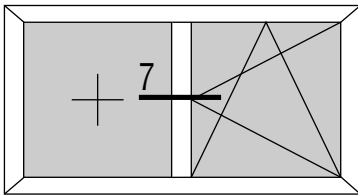
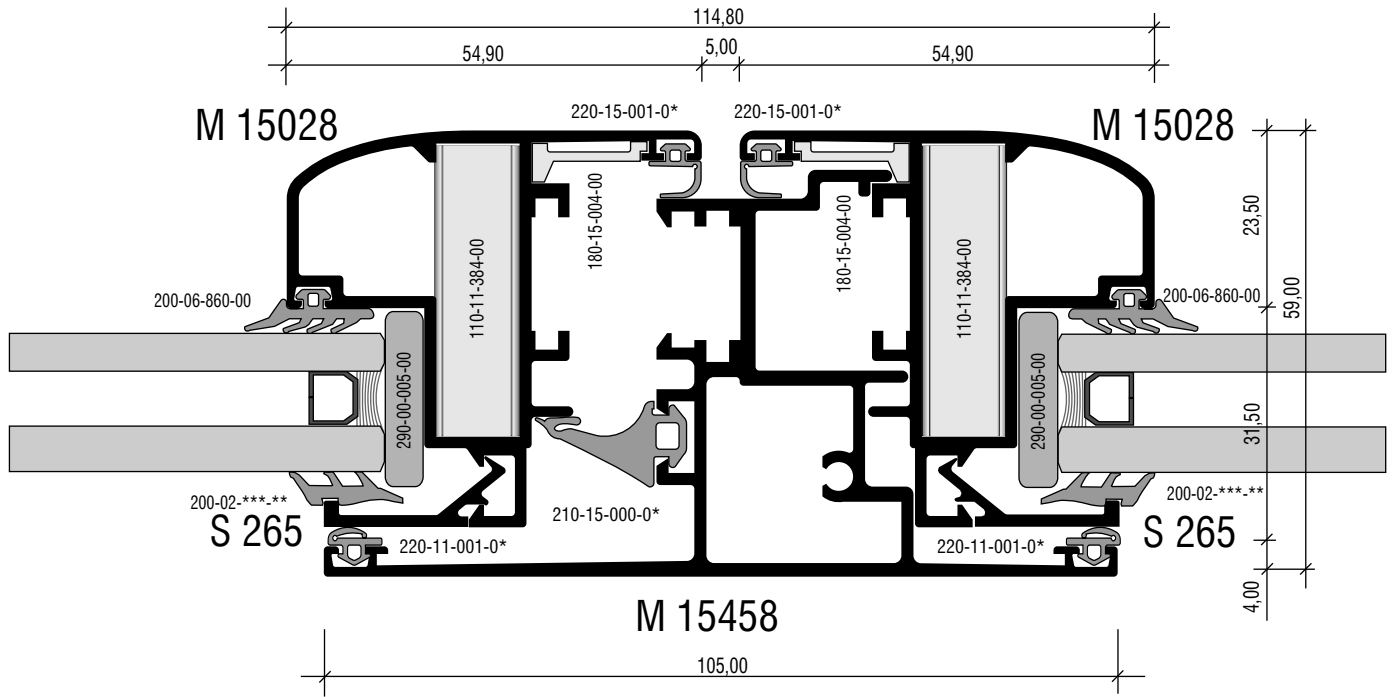
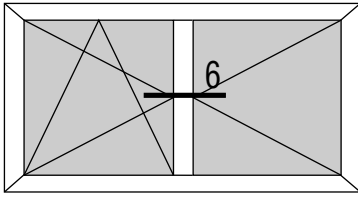

ΠΕΡΙΣΤΡΕΦΟΜΕΝΟ ΠΑΡΑΘΥΡΟ PIVOTING WINDOW

Οι μντεσέδες μπαίνουν οριζόντια ή κάθετα
Hinges could be placed horizontally and vertically

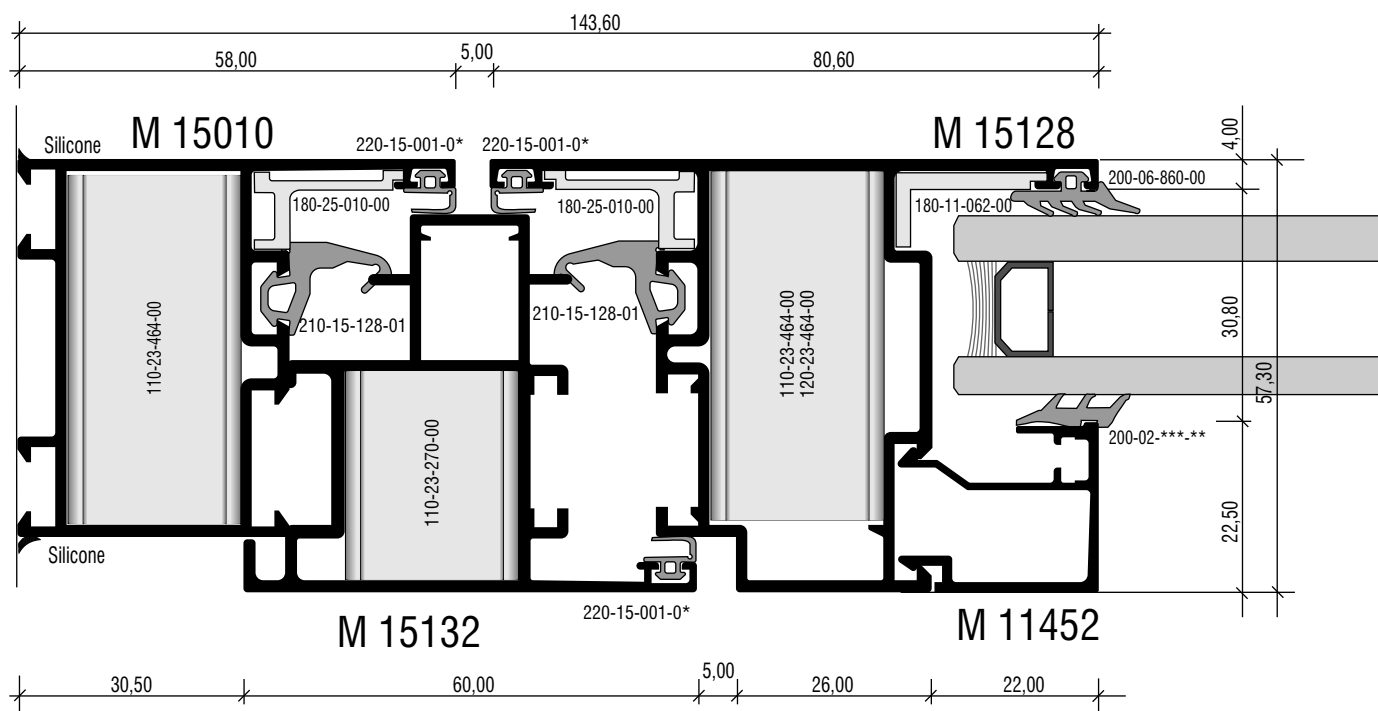
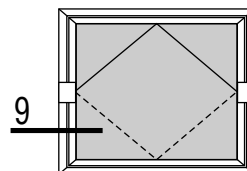
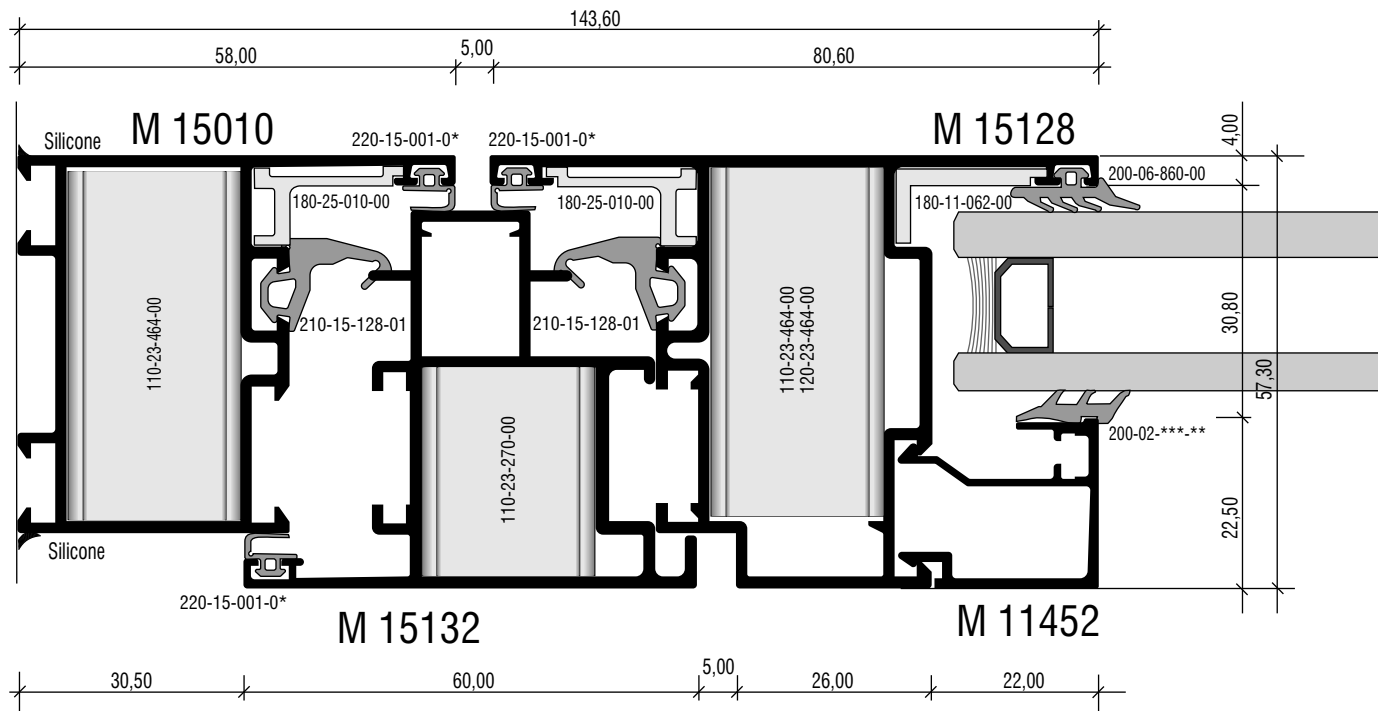
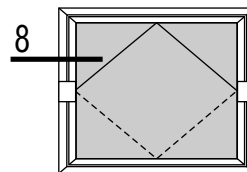

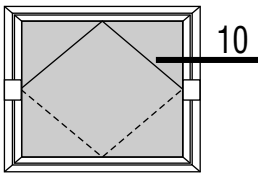

10

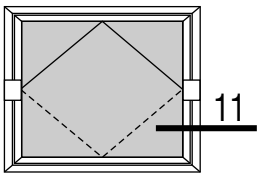
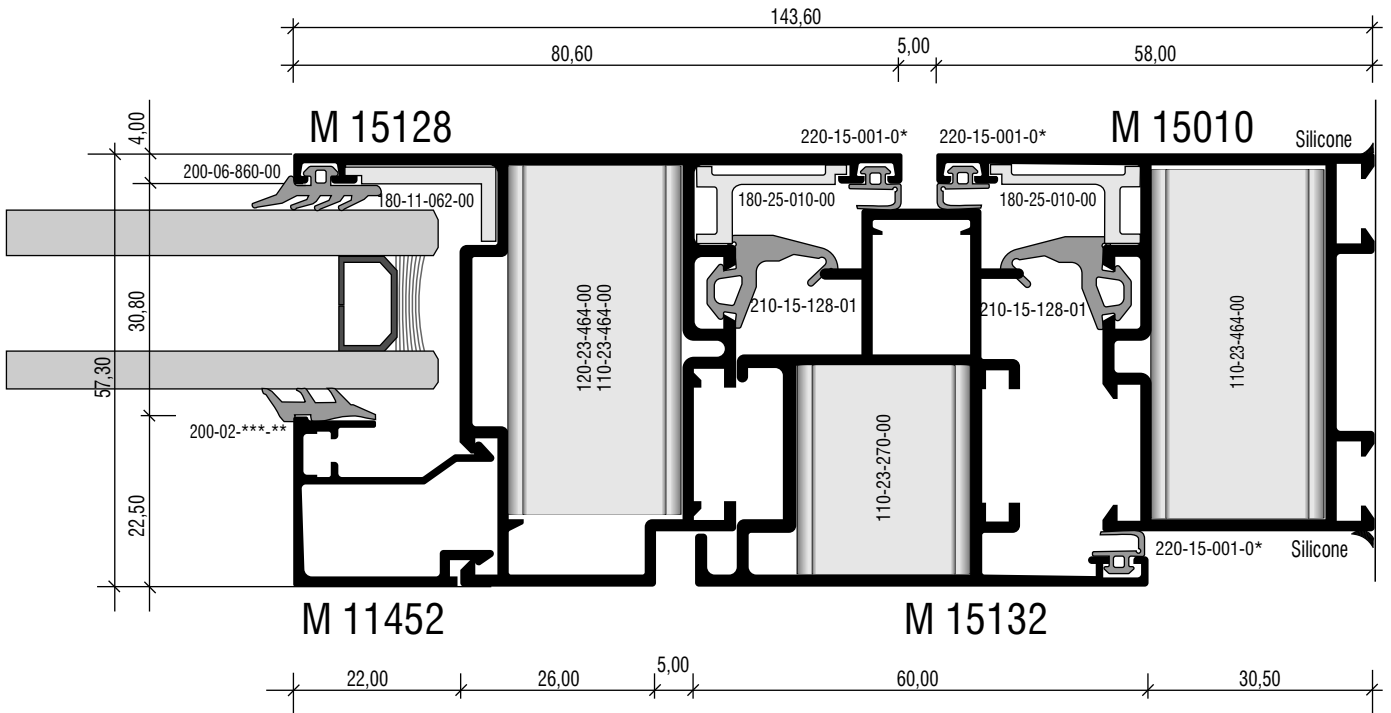

11

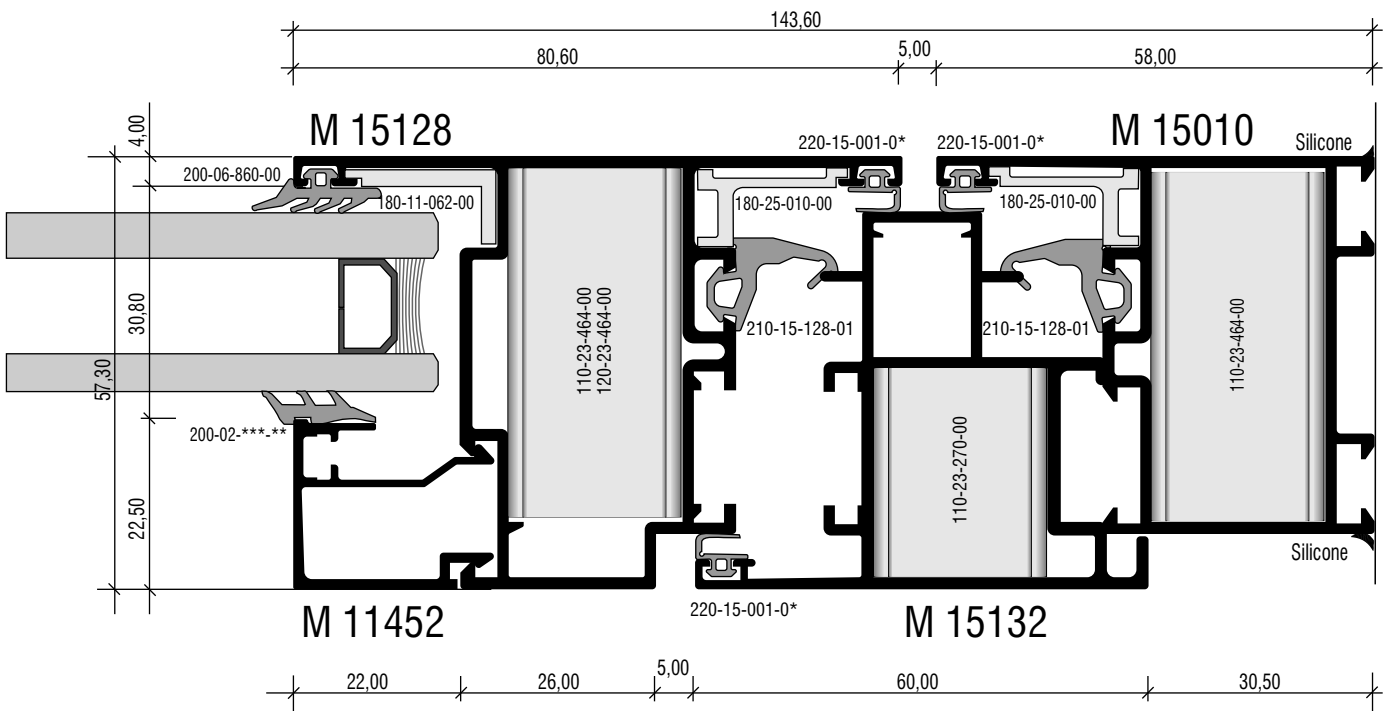

ΜΠΑΛΚΟΝΟΠΟΡΤΕΣ - BALCONY DOORS

ΛΥΣΗ ΓΙΑ ΤΖΑΜΙ - ΠΑΝΤΖΟΥΡΙ ΞΕΧΩΡΙΣΤΑ
SOLUTION FOR GLAZING AND SHUTTERS
ON TWO FRAMES

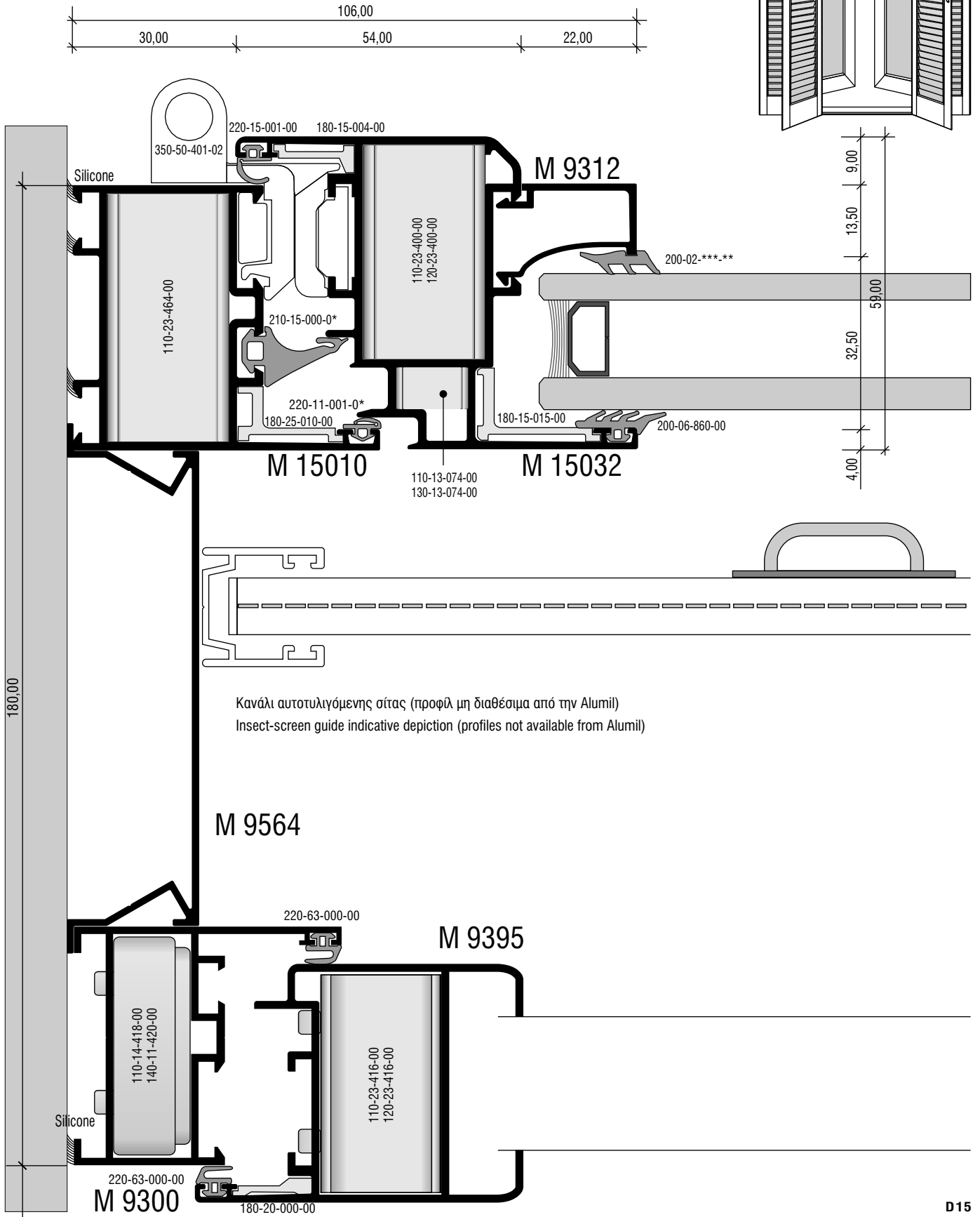

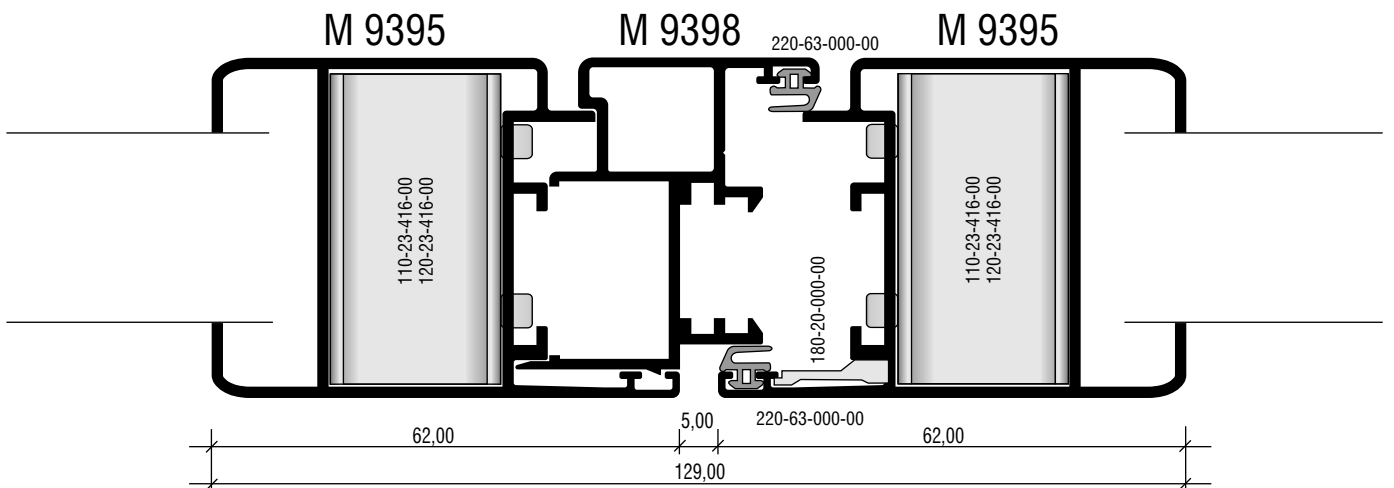
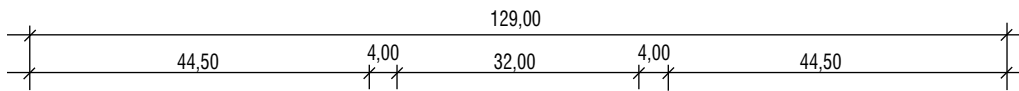
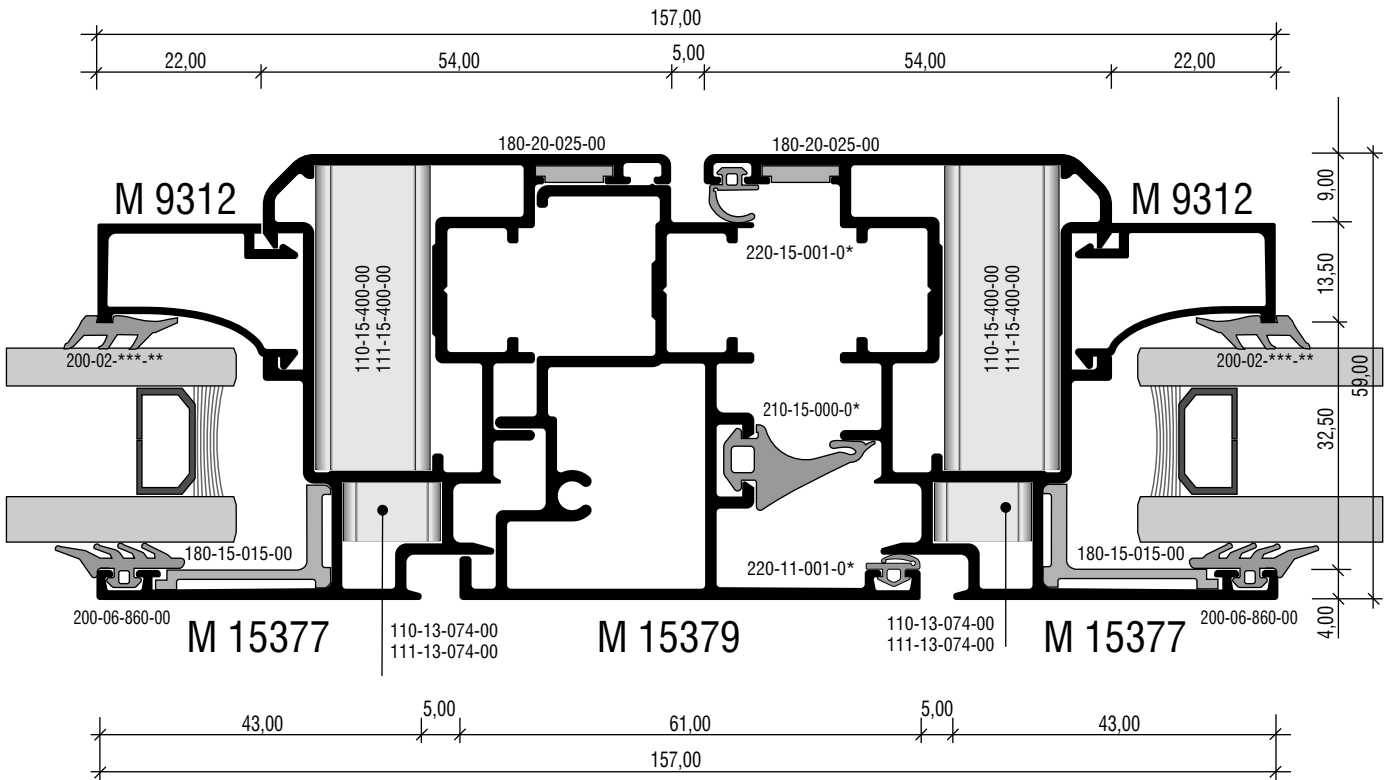
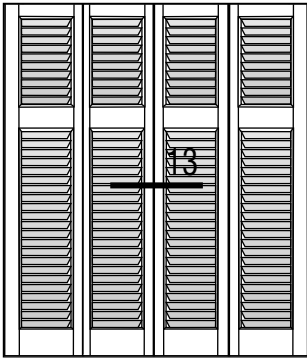

ΛΥΣΗ ΓΙΑ ΤΖΑΜΙ - ΠΑΝΤΖΟΥΡΙ ΜΕ ΔΙΑΙΡΟΥΜΕΝΗ ΚΑΣΑ
 SOLUTION FOR GLAZING AND SHUTTERS
 WITH A TWO - PIECE FRAME

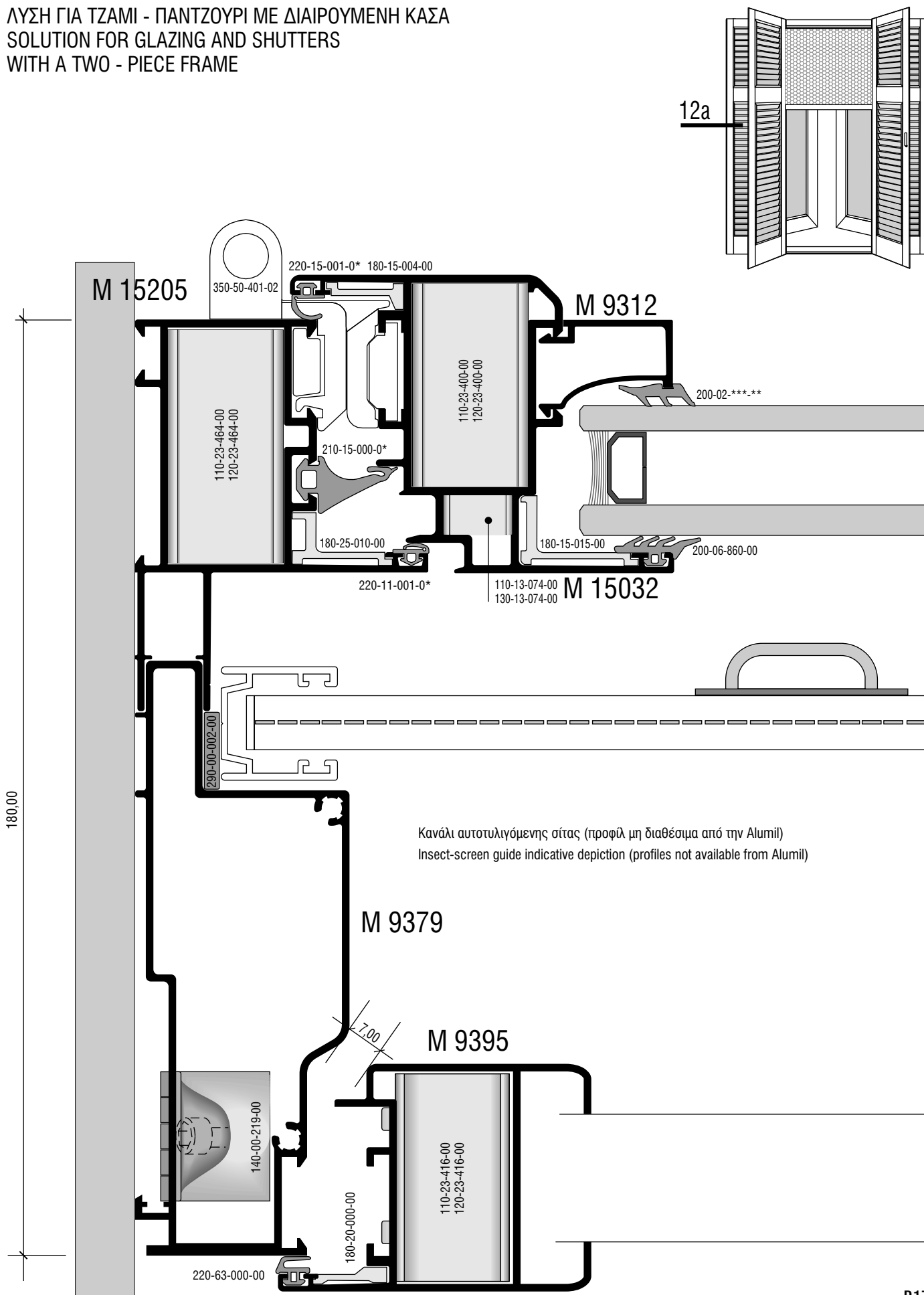

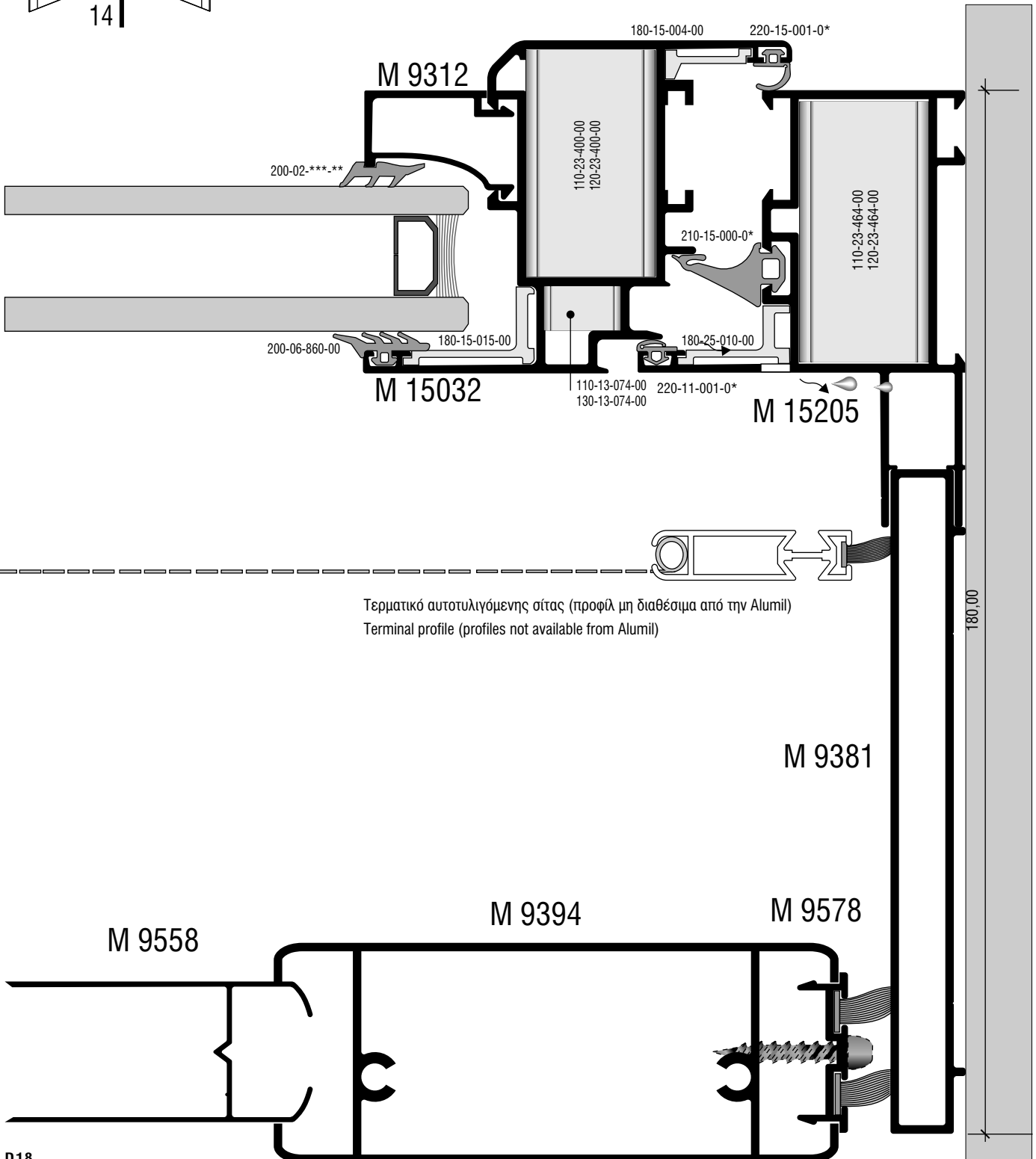
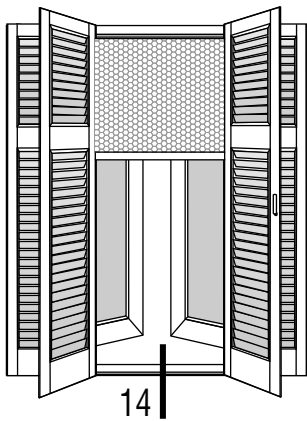

ΛΥΣΗ ΓΙΑ ΤΖΑΜΙ - ΠΑΝΤΖΟΥΡΙ ΜΕ ΕΝΙΑΙΑ ΚΑΣΑ
 SOLUTION FOR GLAZING AND SHUTTERS
 WITH A SINGLE FRAME

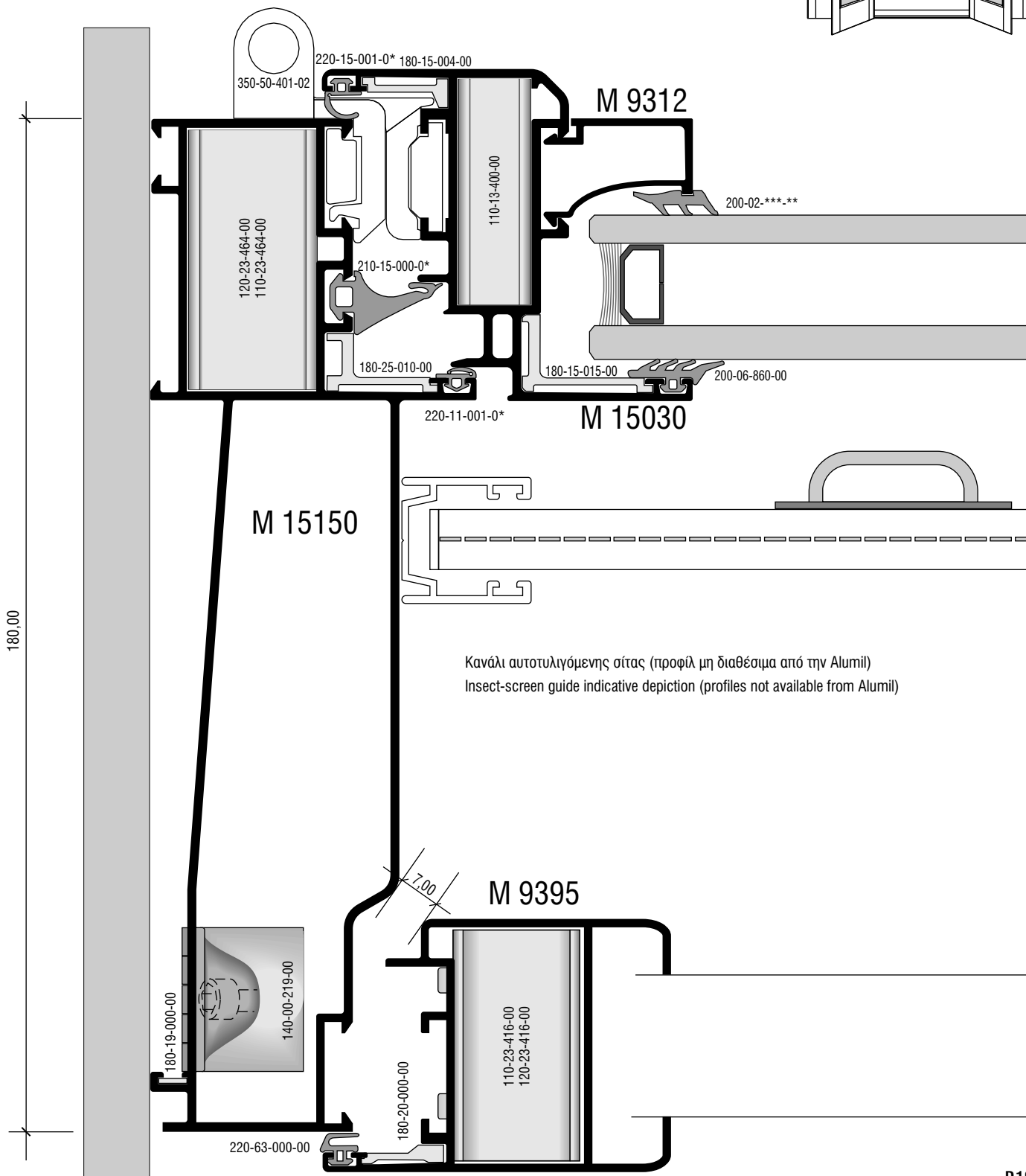
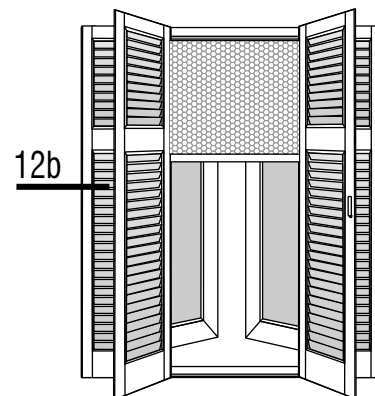

ΛΥΣΗ ΓΙΑ ΤΖΑΜΙ - ΠΑΝΤΖΟΥΡΙ ΜΕ ΚΑΣΑ ΓΙΑ ΔΙΧΡΩΜΙΕΣ
 SOLUTION FOR GLAZING AND SHUTTERS
 IN A TWO - COLOR WINDOW

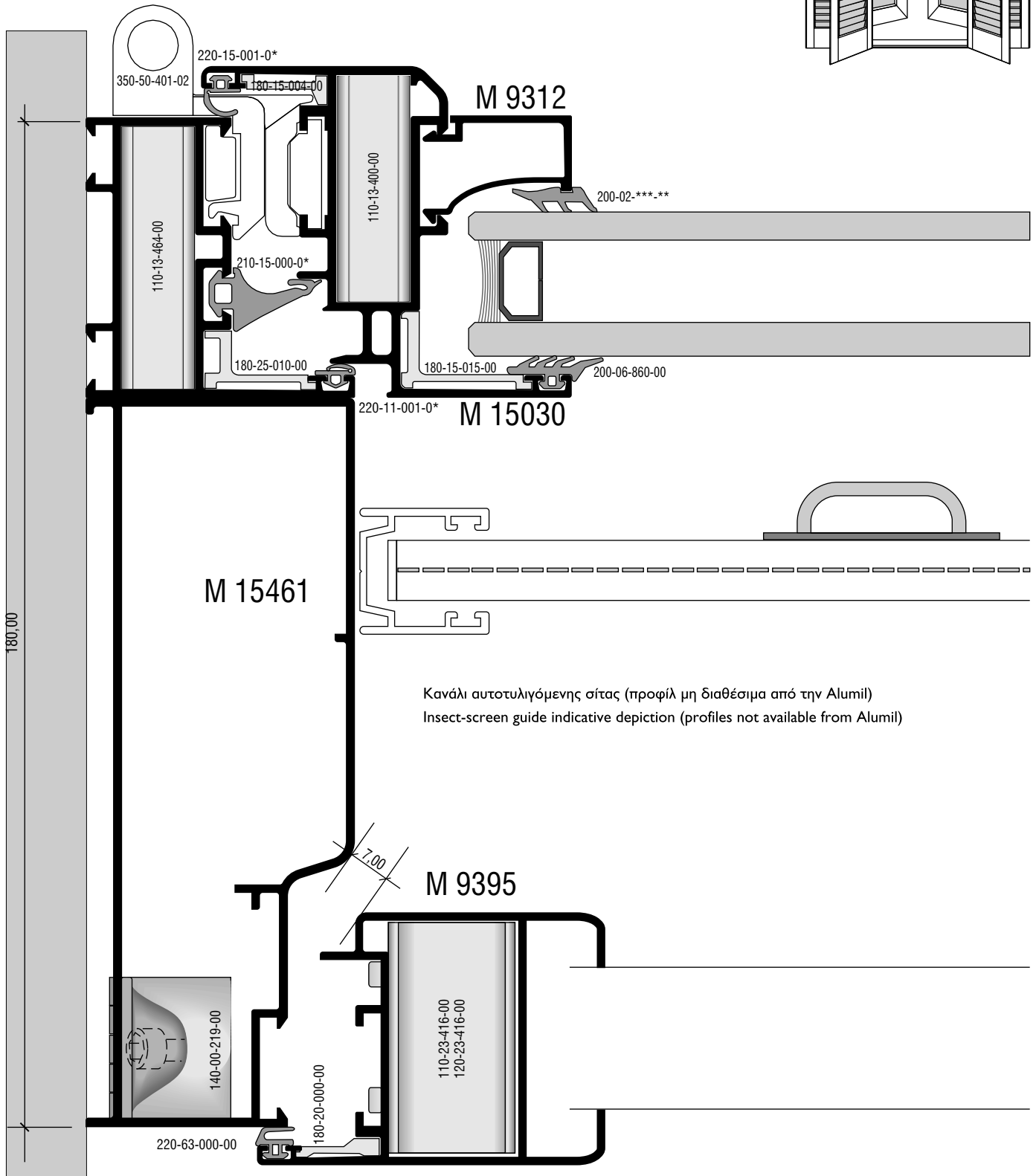
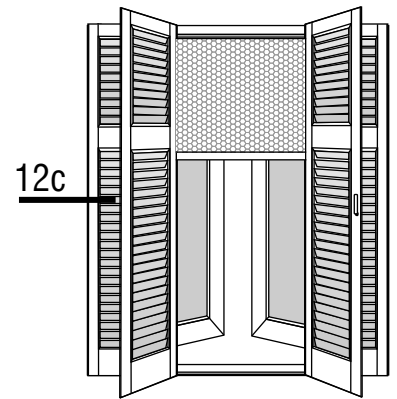

ΛΥΣΗ ΓΙΑ ΤΖΑΜΙ ΜΕ ΡΟΛΟ
SOLUTION WITH ROLLING SHUTTERS

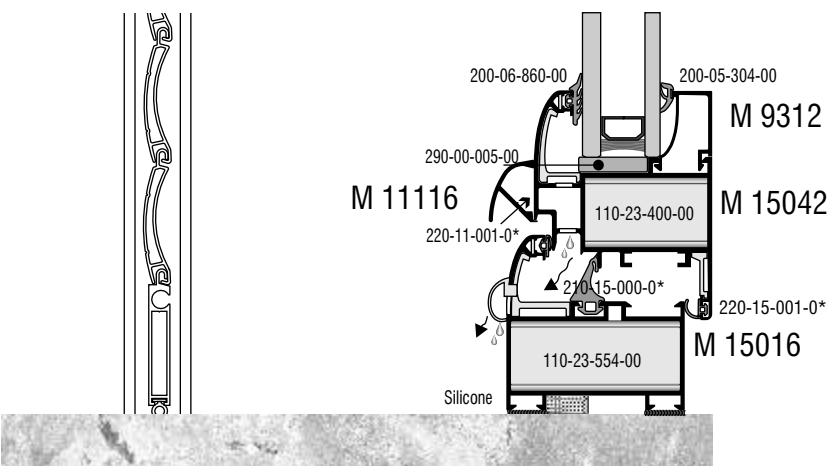
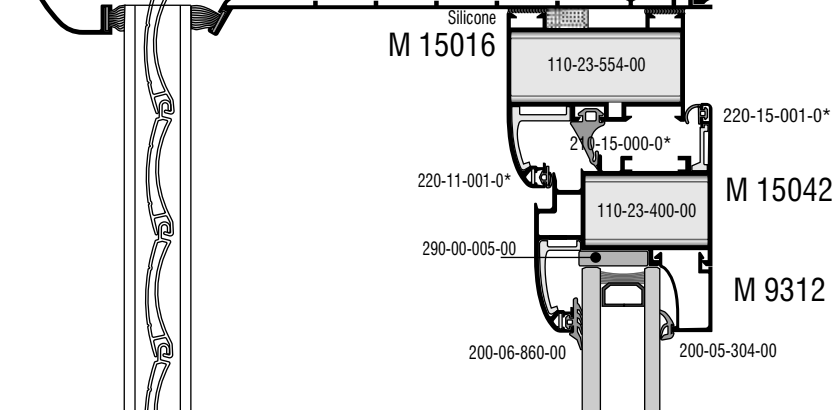
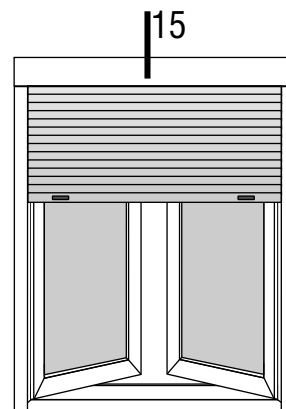
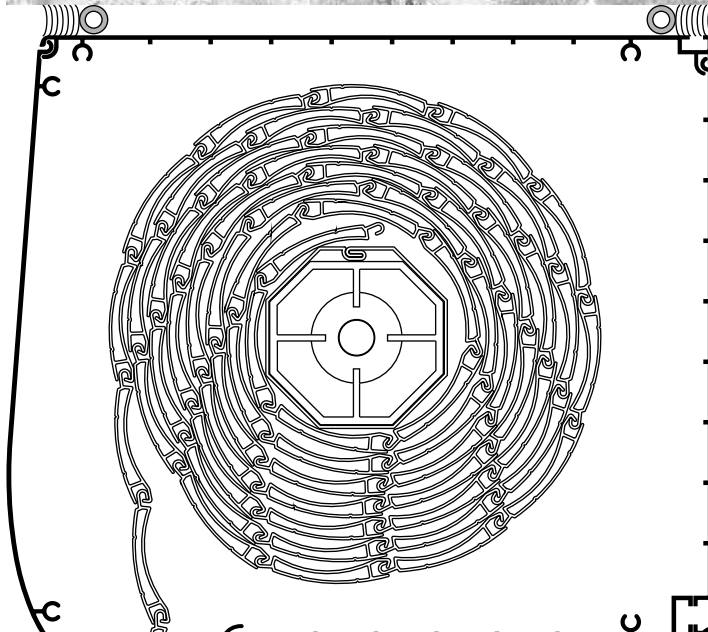
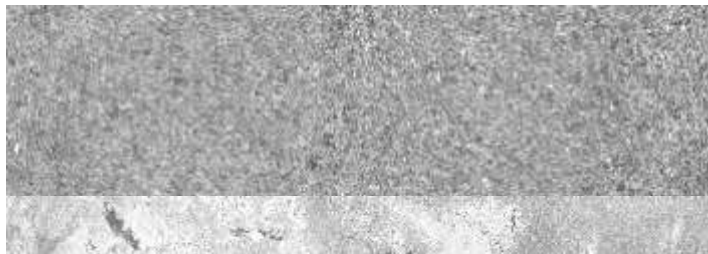

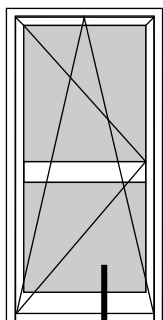

16 |

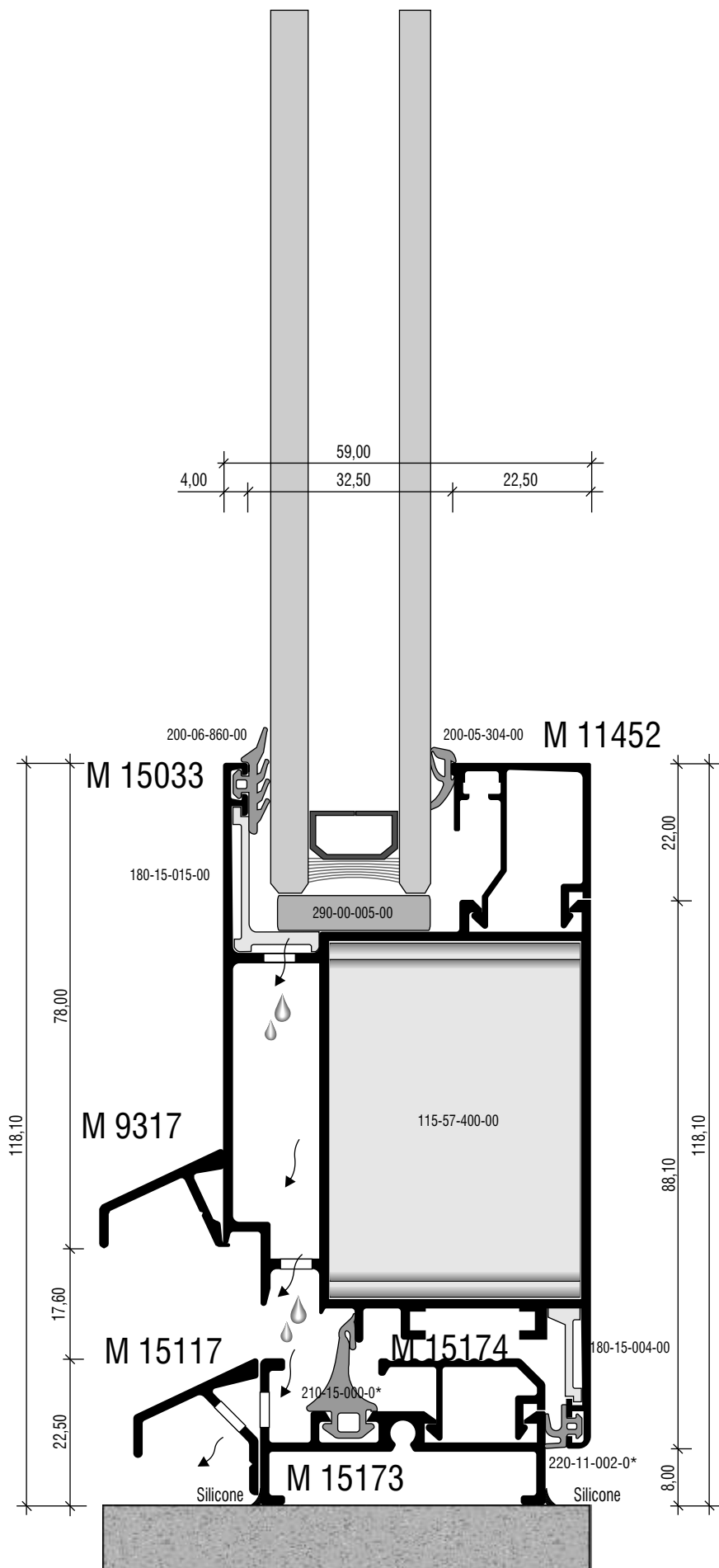

ΕΙΣΟΔΟΙ - ENTRANCE DOORS

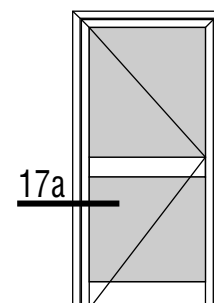
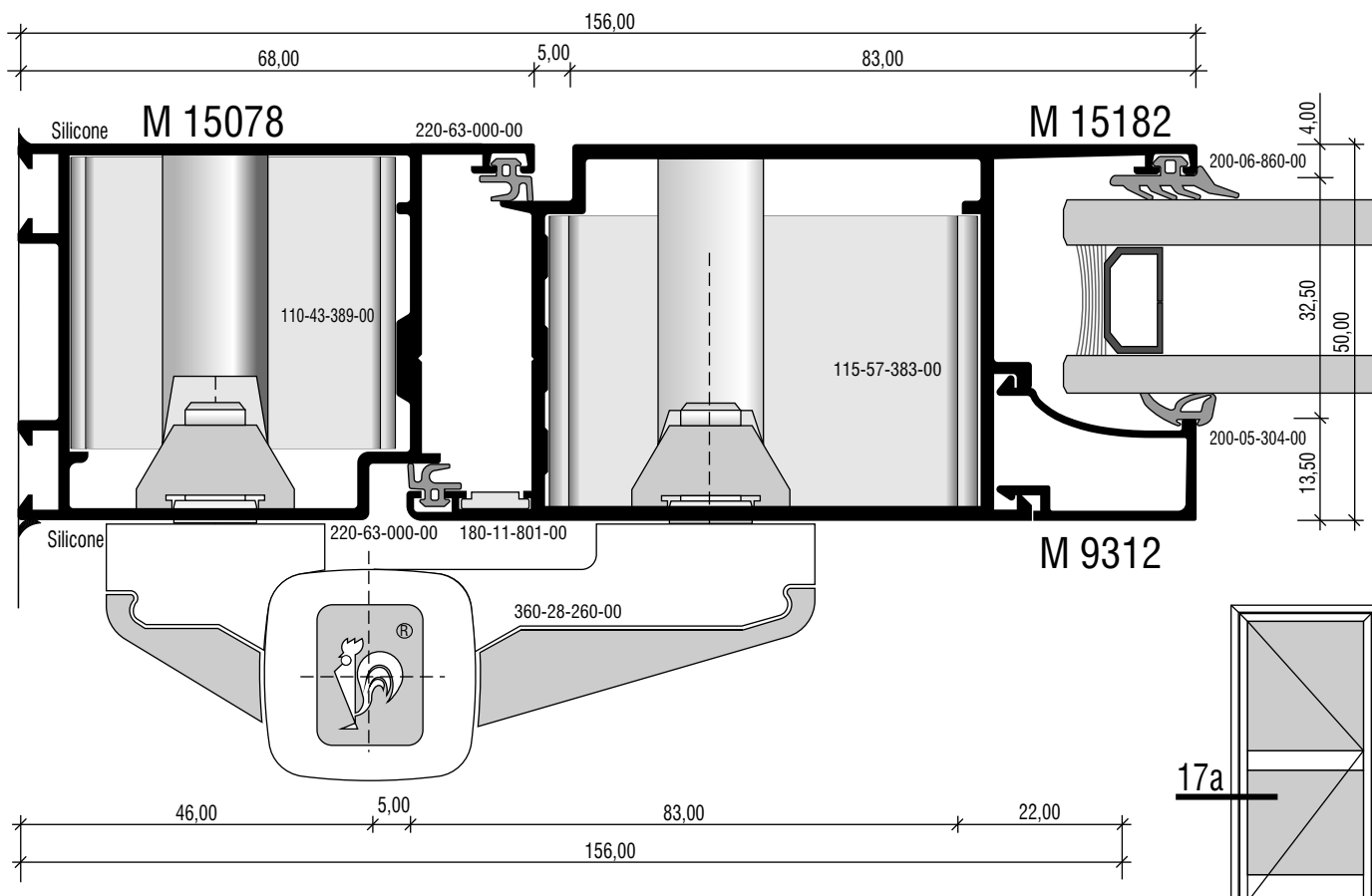
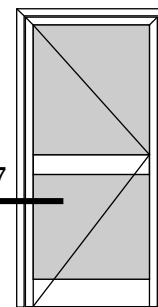
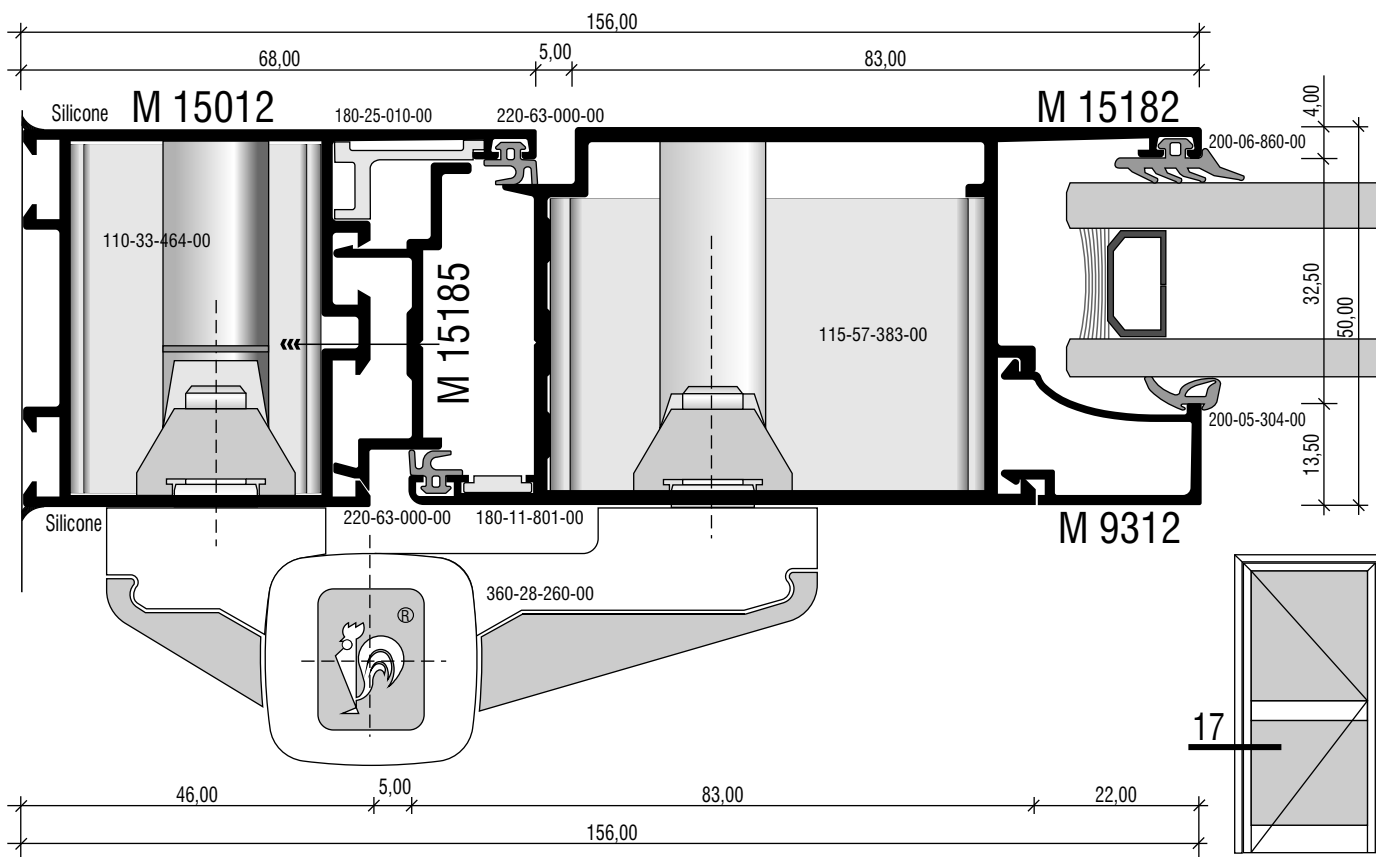

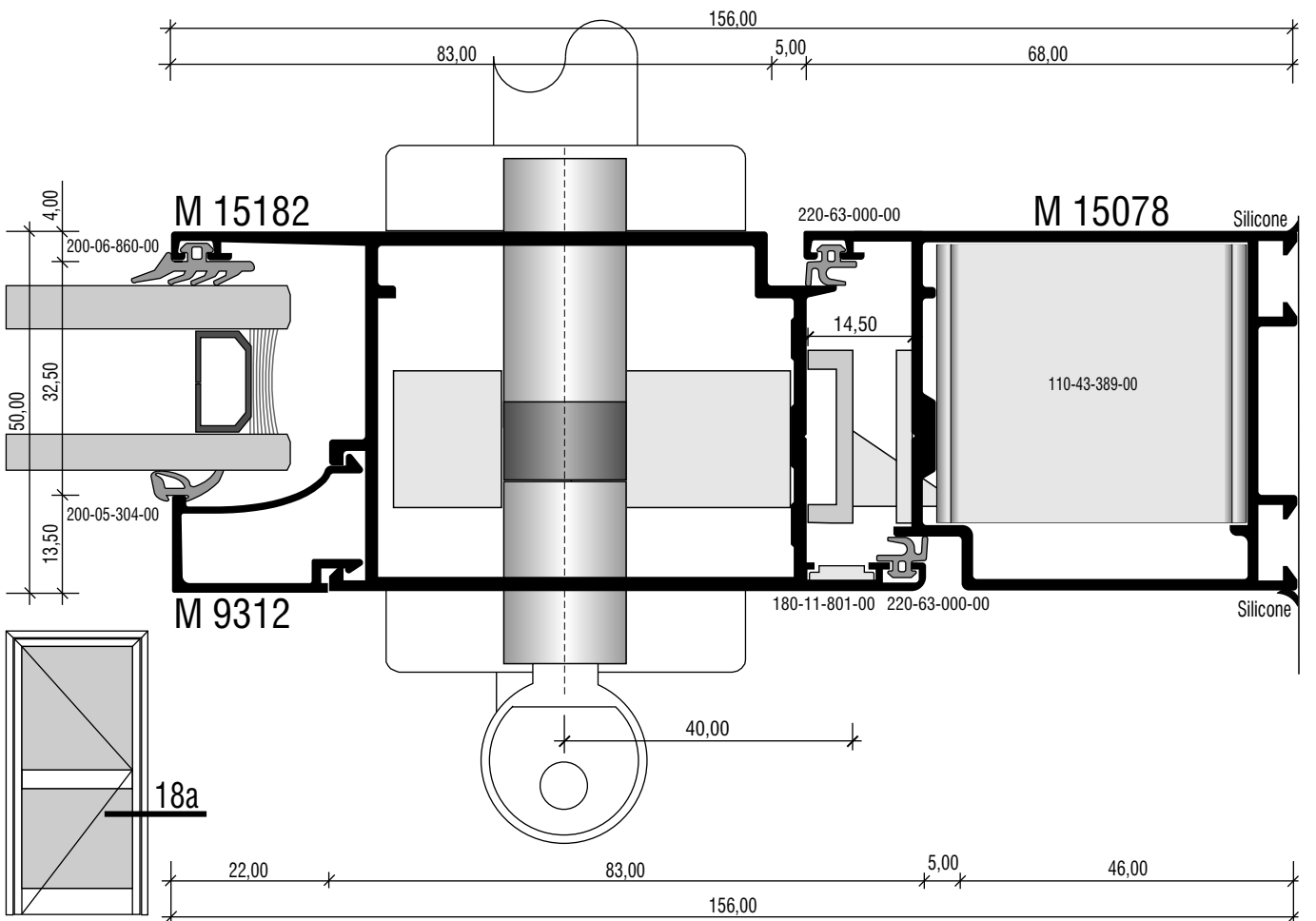
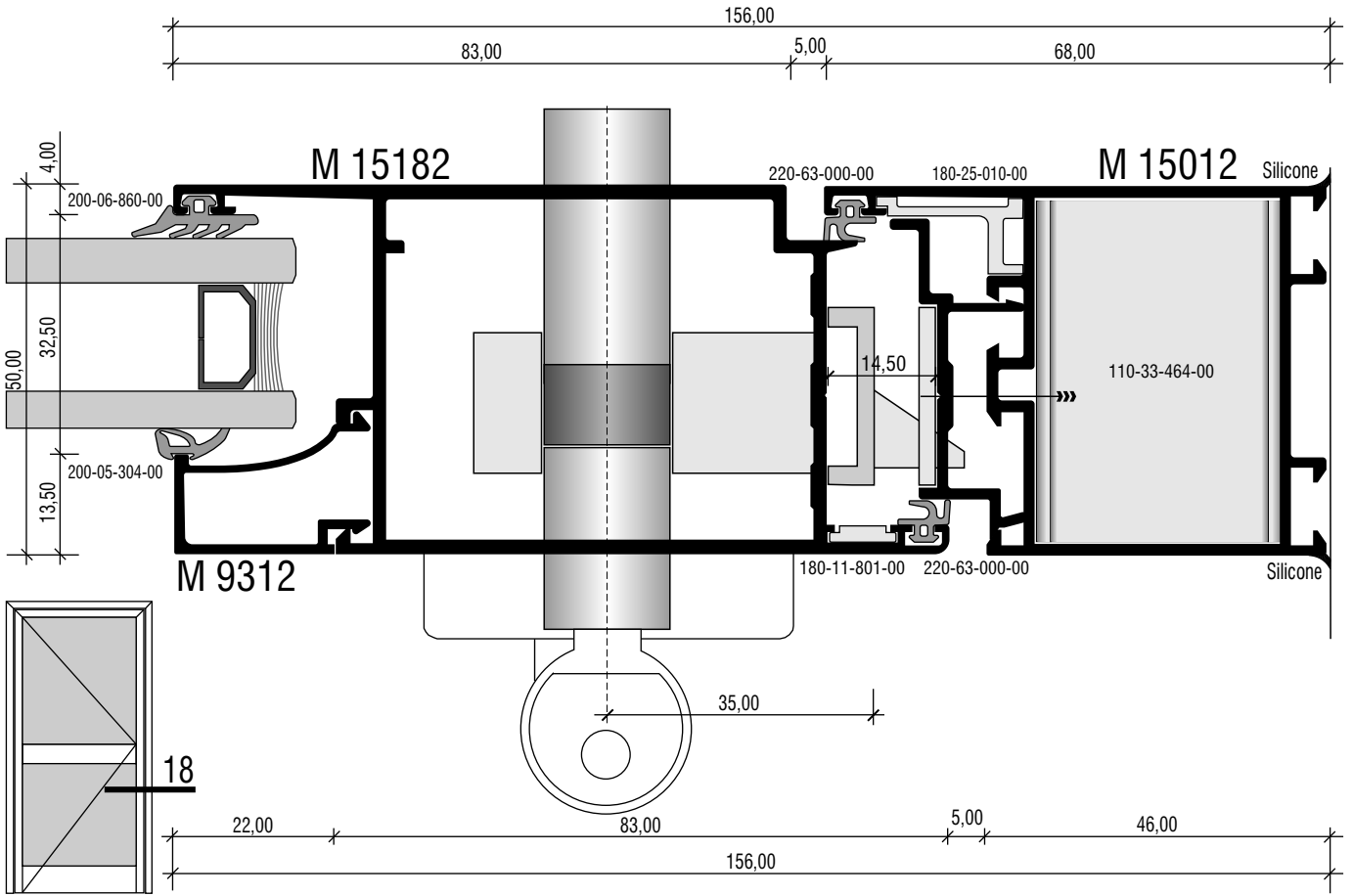

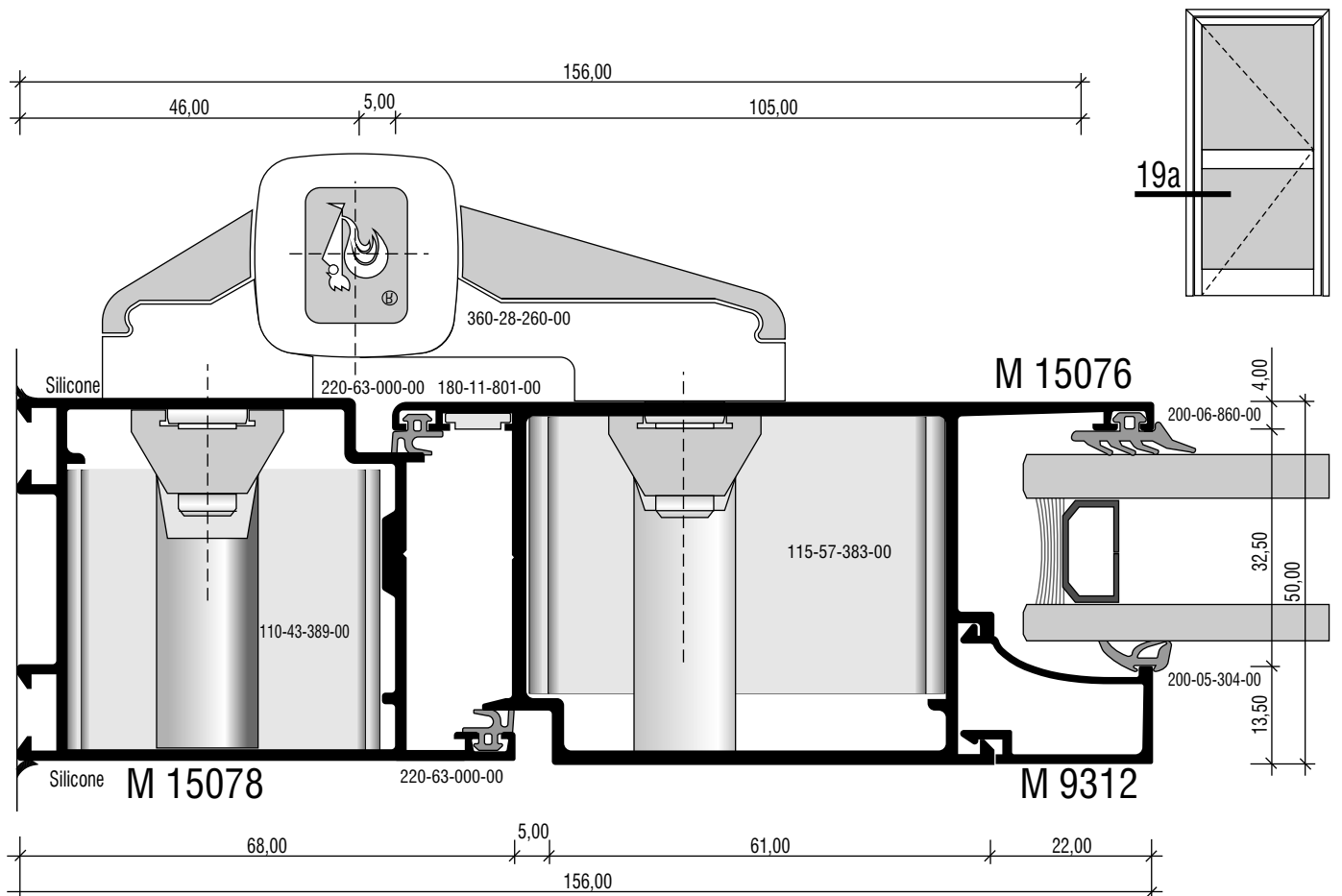
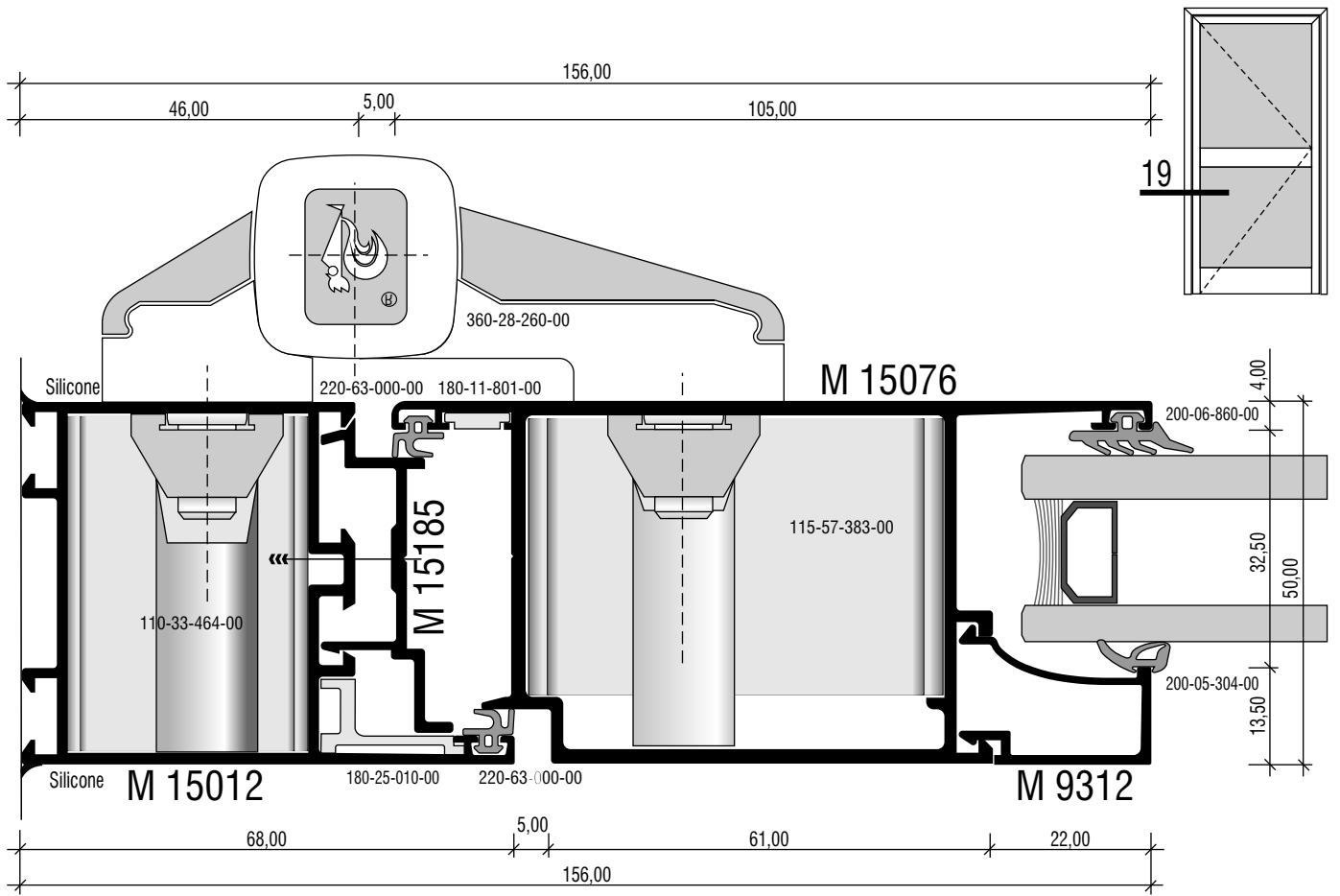

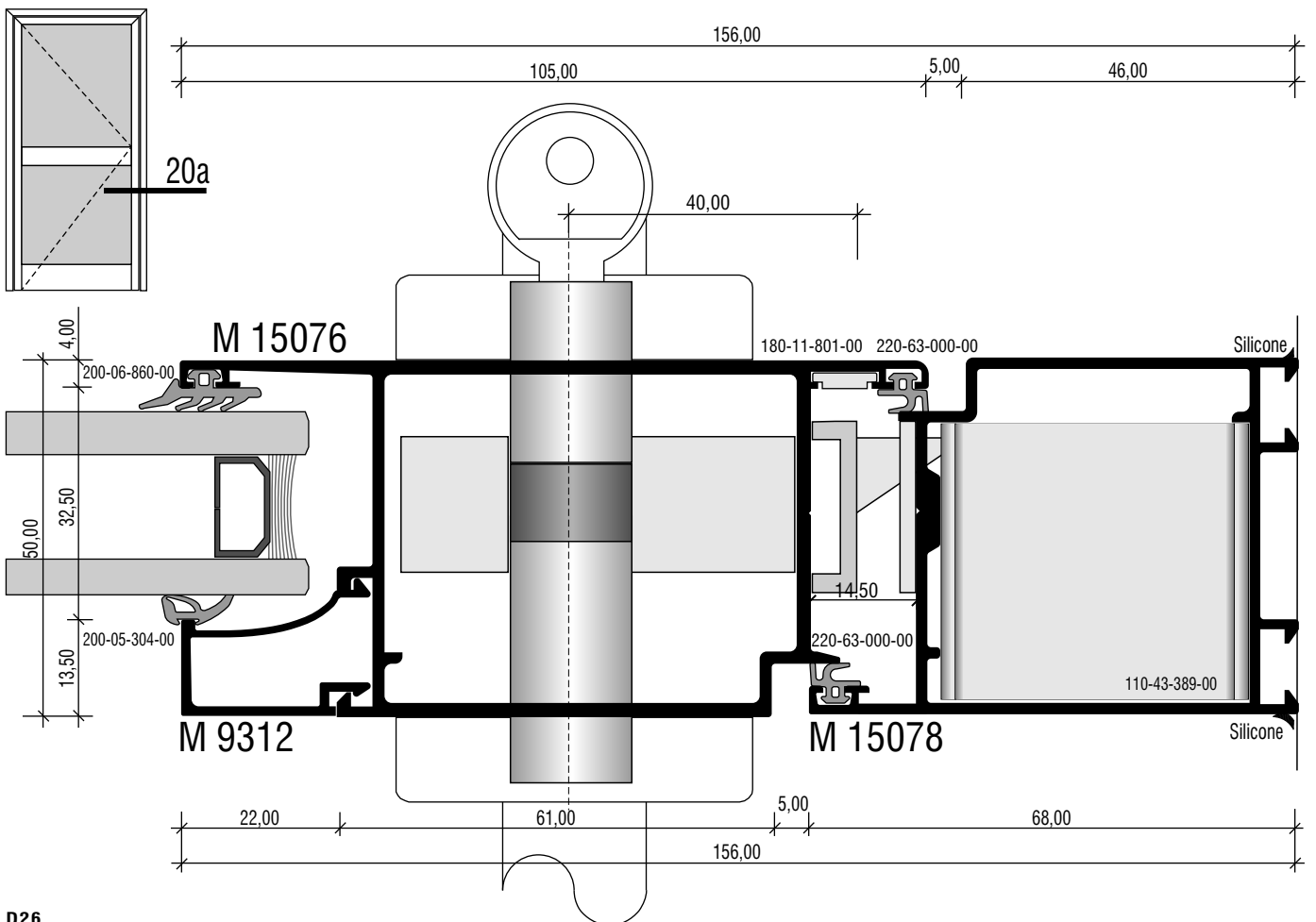
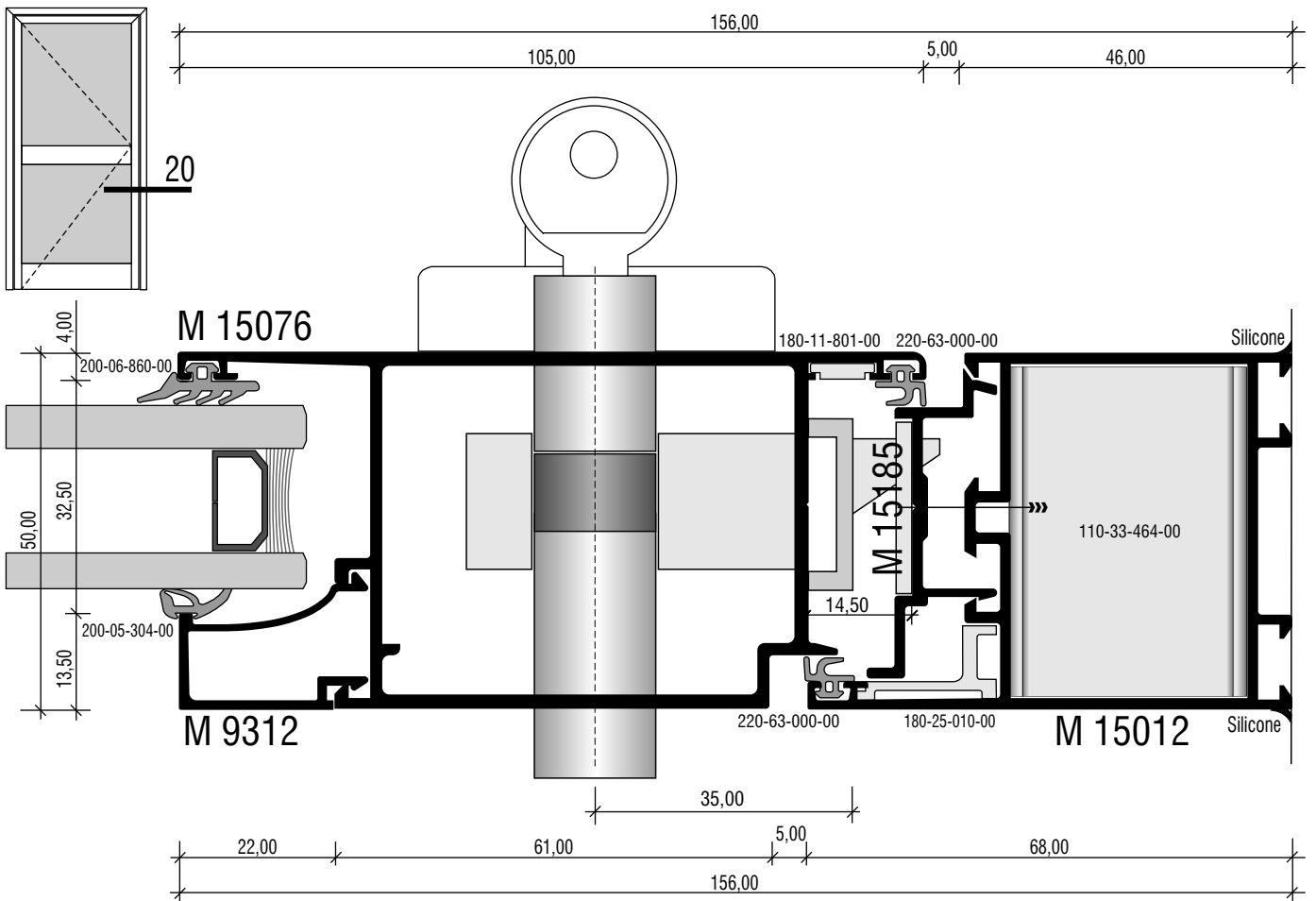

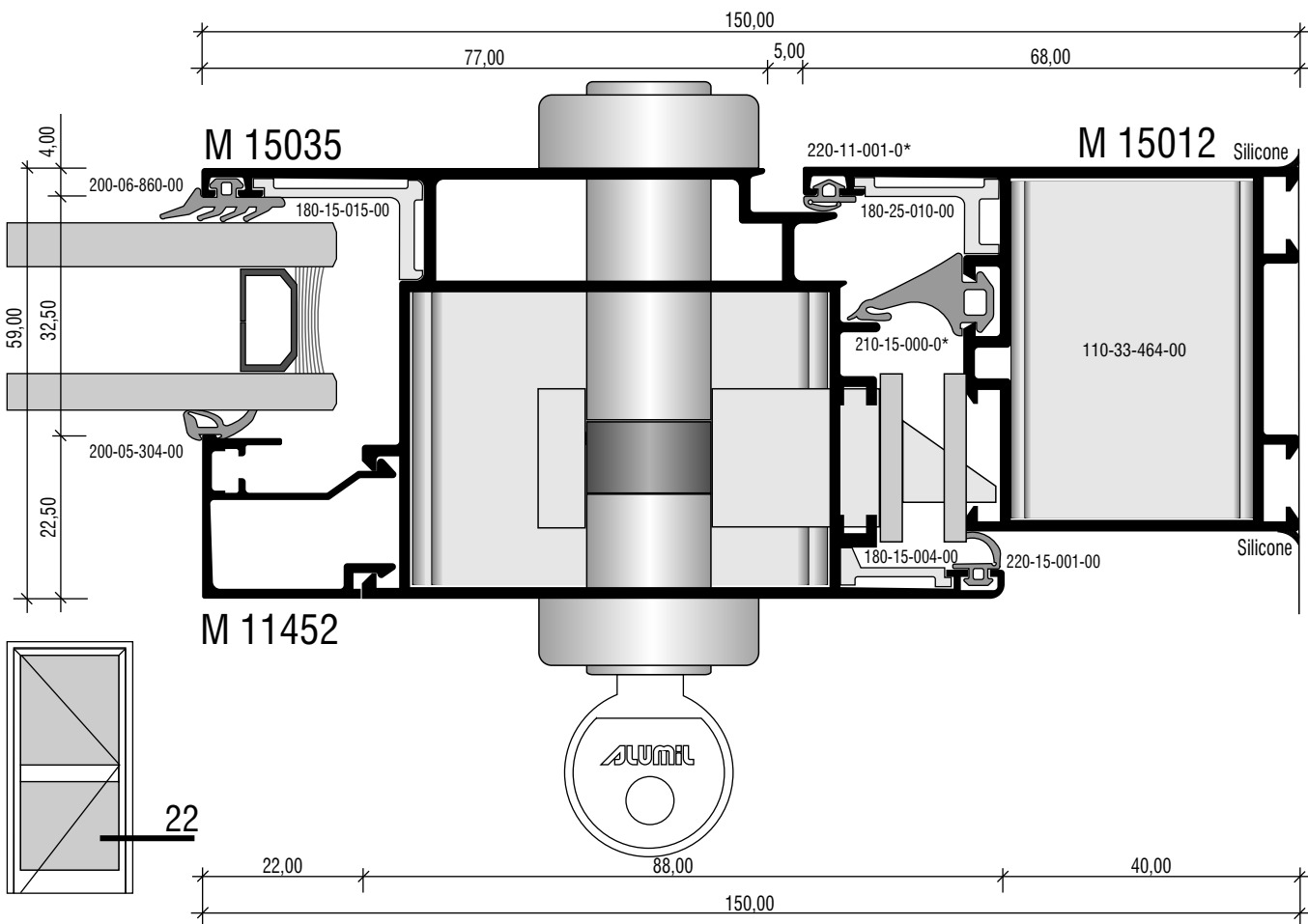
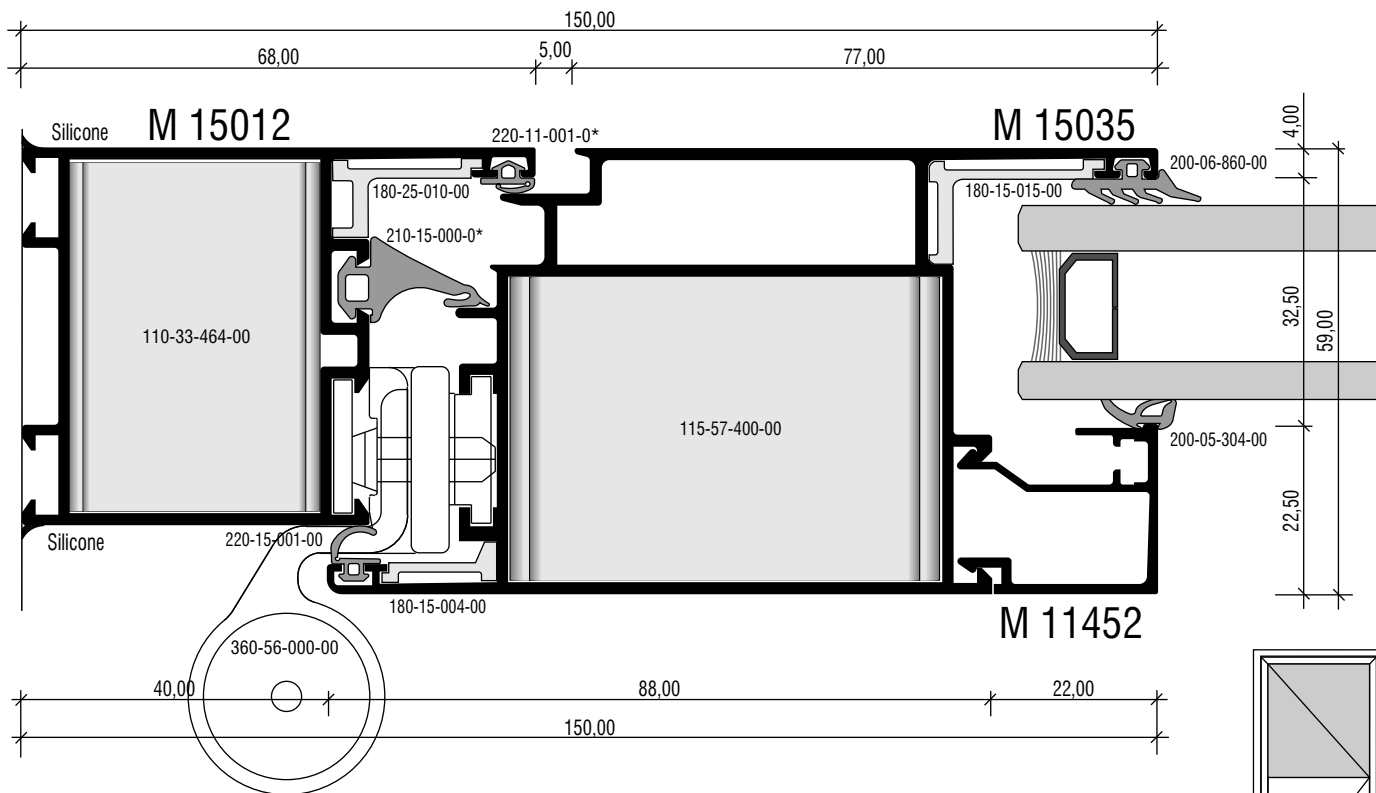

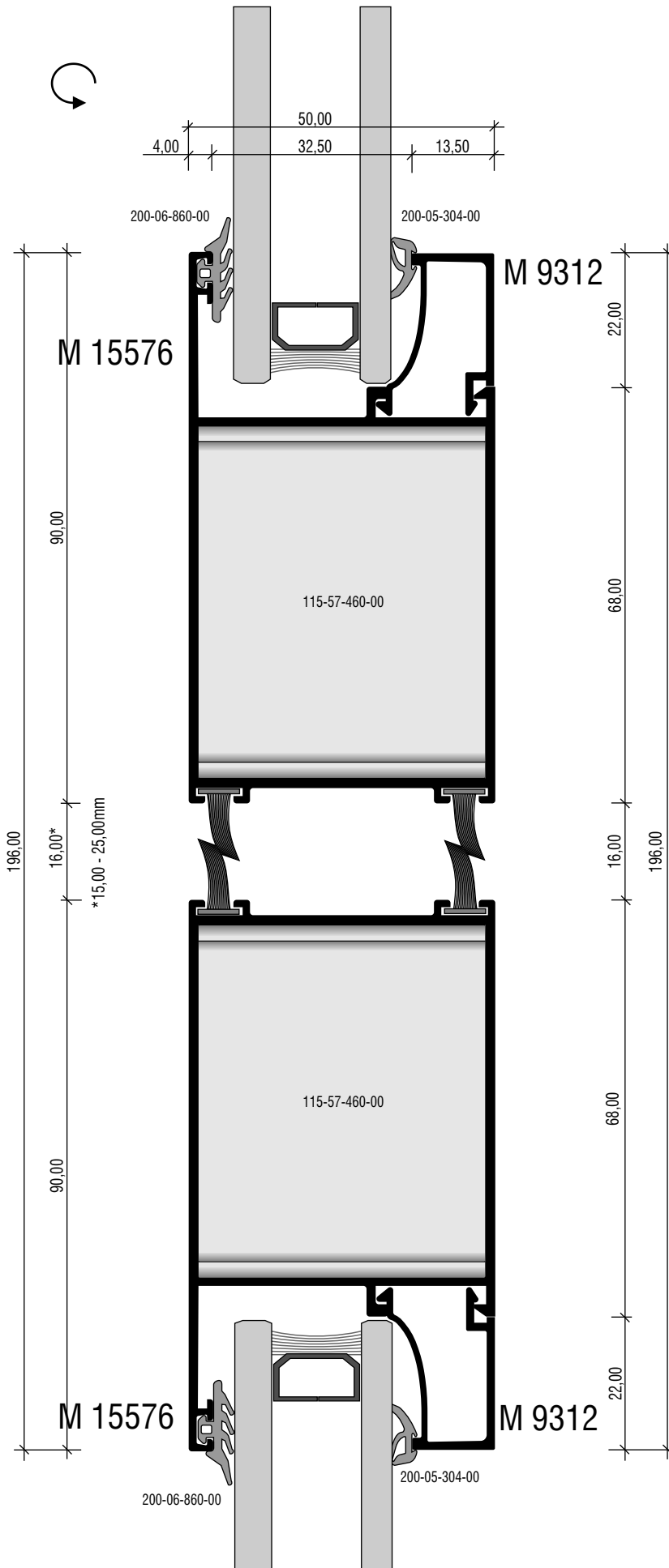
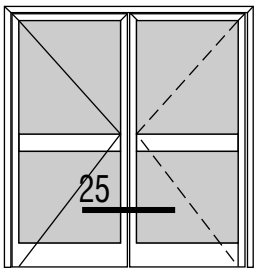

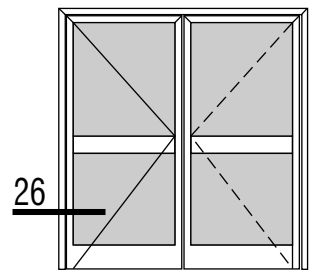
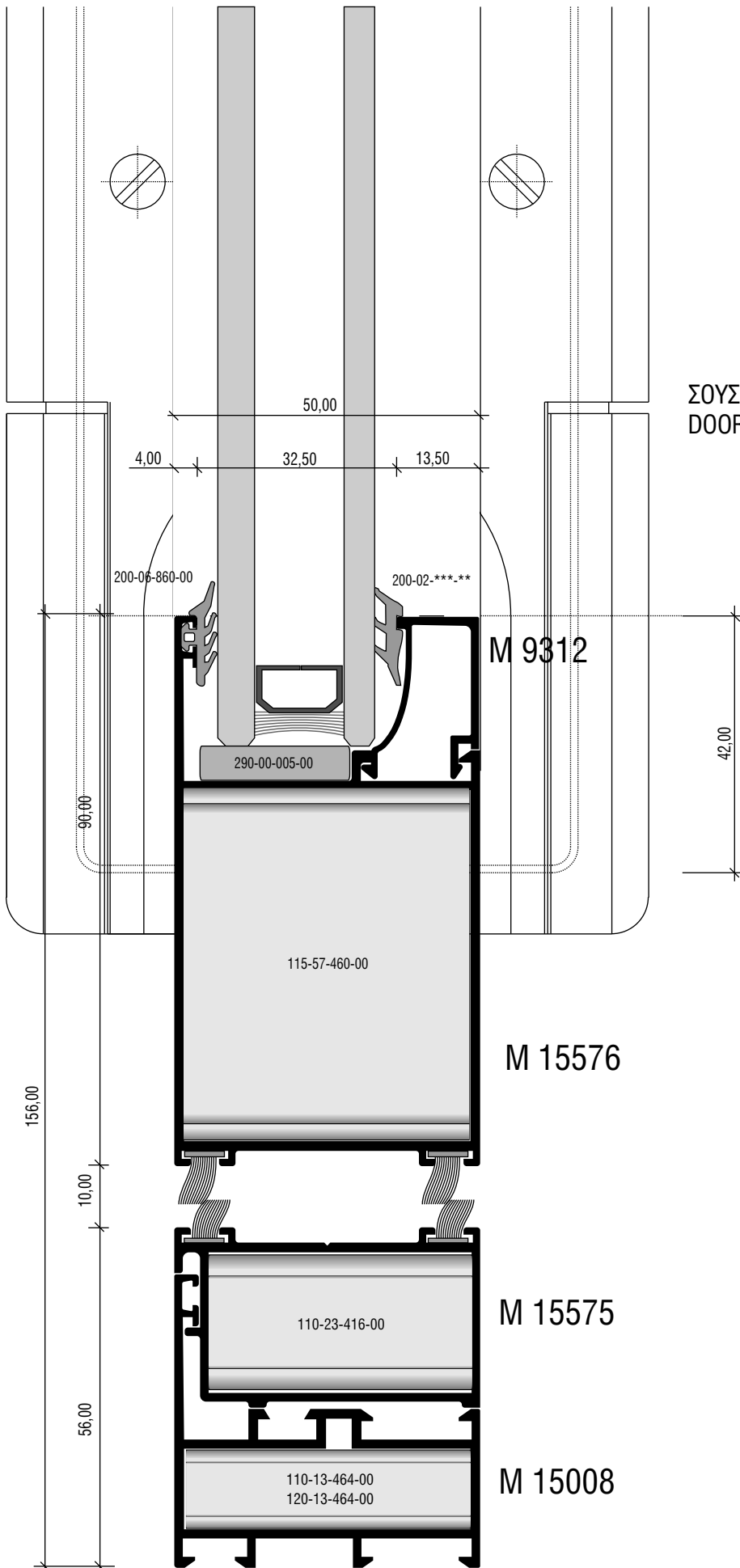

ΣΟΥΣΤΑ ΕΠΑΝΑΦΟΡΑΣ
DOOR CLOSER

ΕΙΣΟΔΟΣ “ΑΛΕ - ΡΕΤΟΥΡ”
ENTRANCE FOR DOUBLE SWINGING DOORS

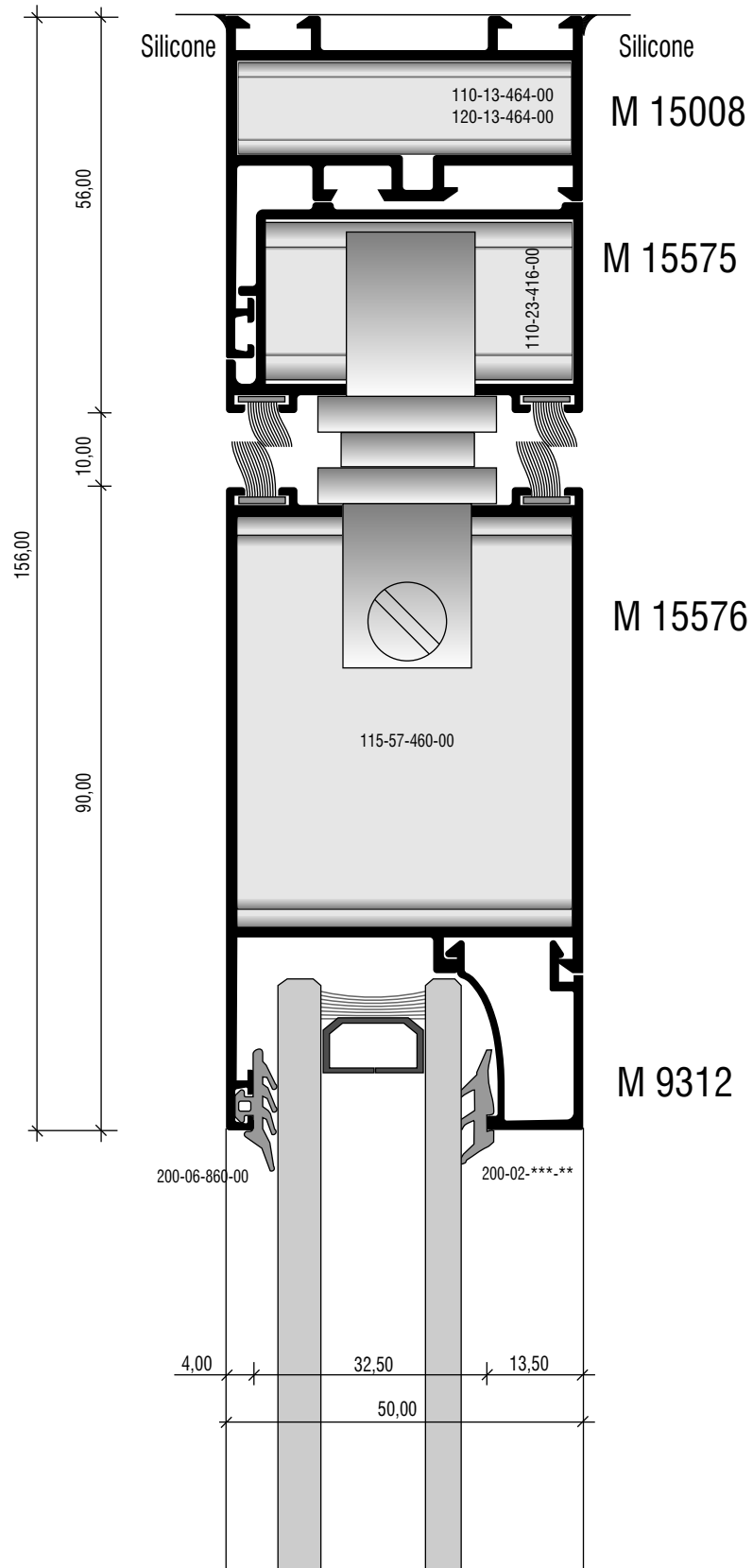
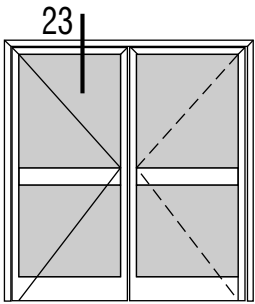

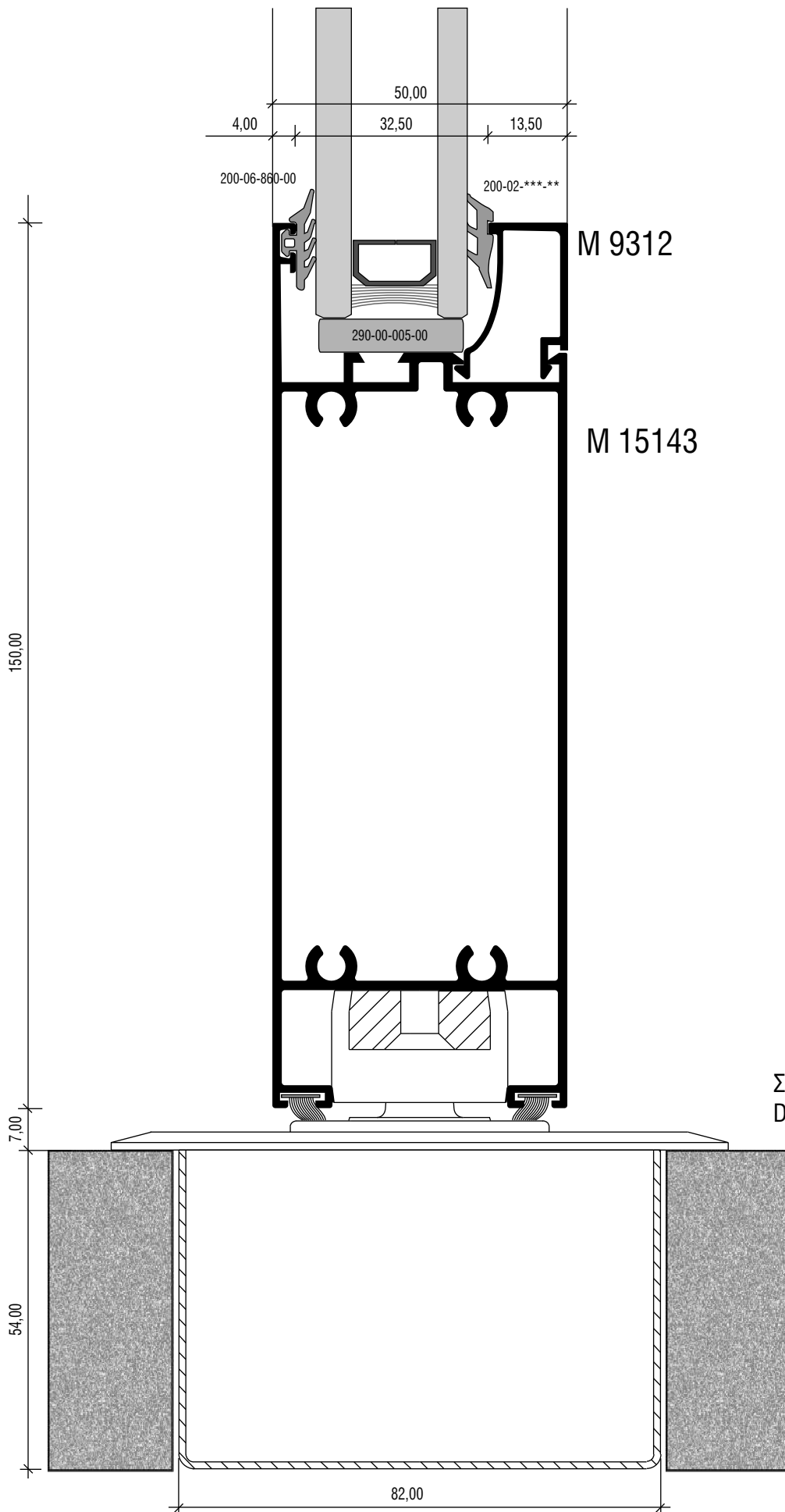

ΣΟΥΣΤΑ ΕΠΑΝΑΦΟΡΑΣ
DOOR CLOSER

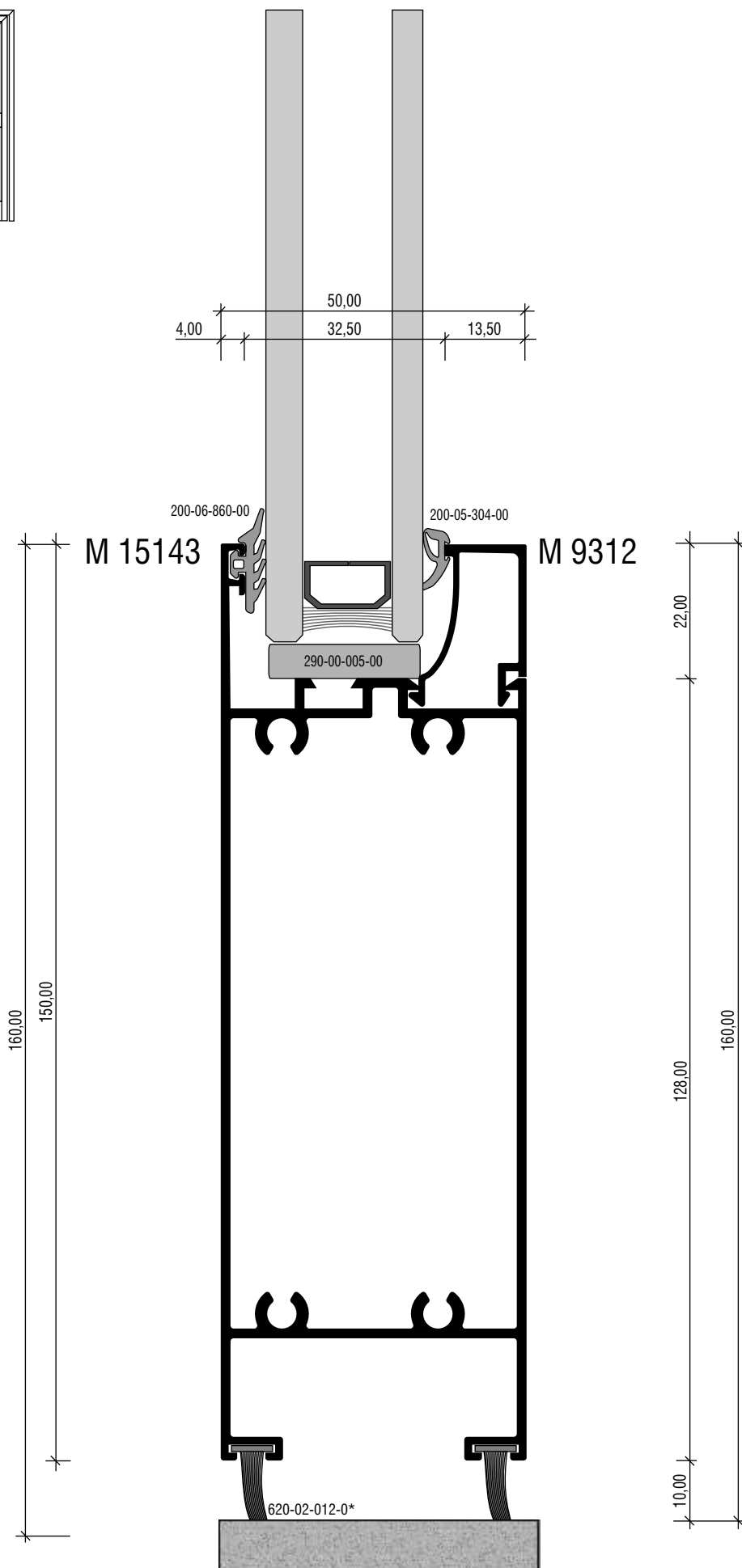
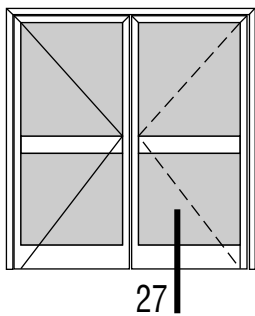

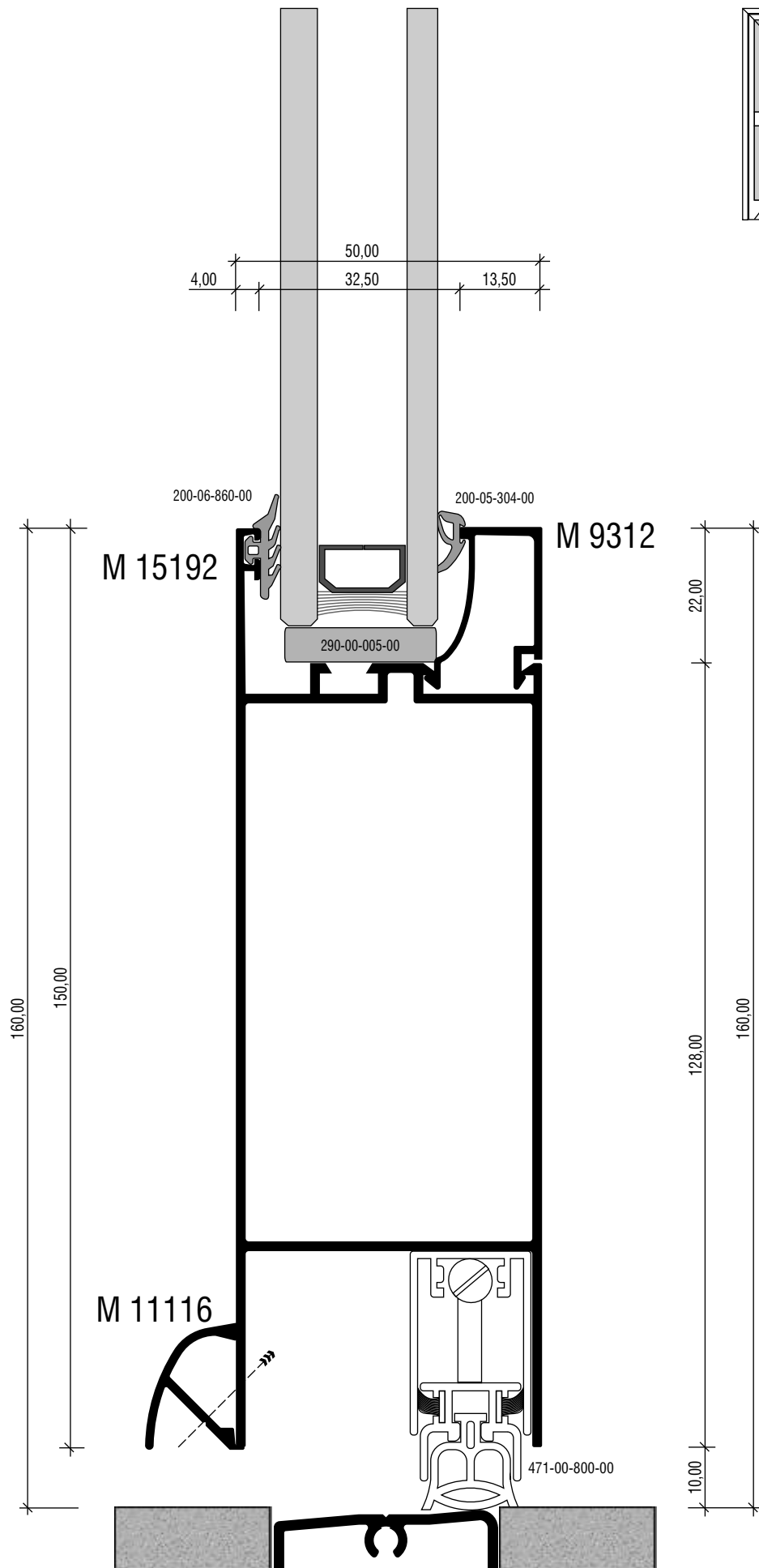

ΕΙΣΟΔΟΙ ΜΕ ΒΙΤΡΙΝΕΣ ENTRANCE FOR STORE FRONTS

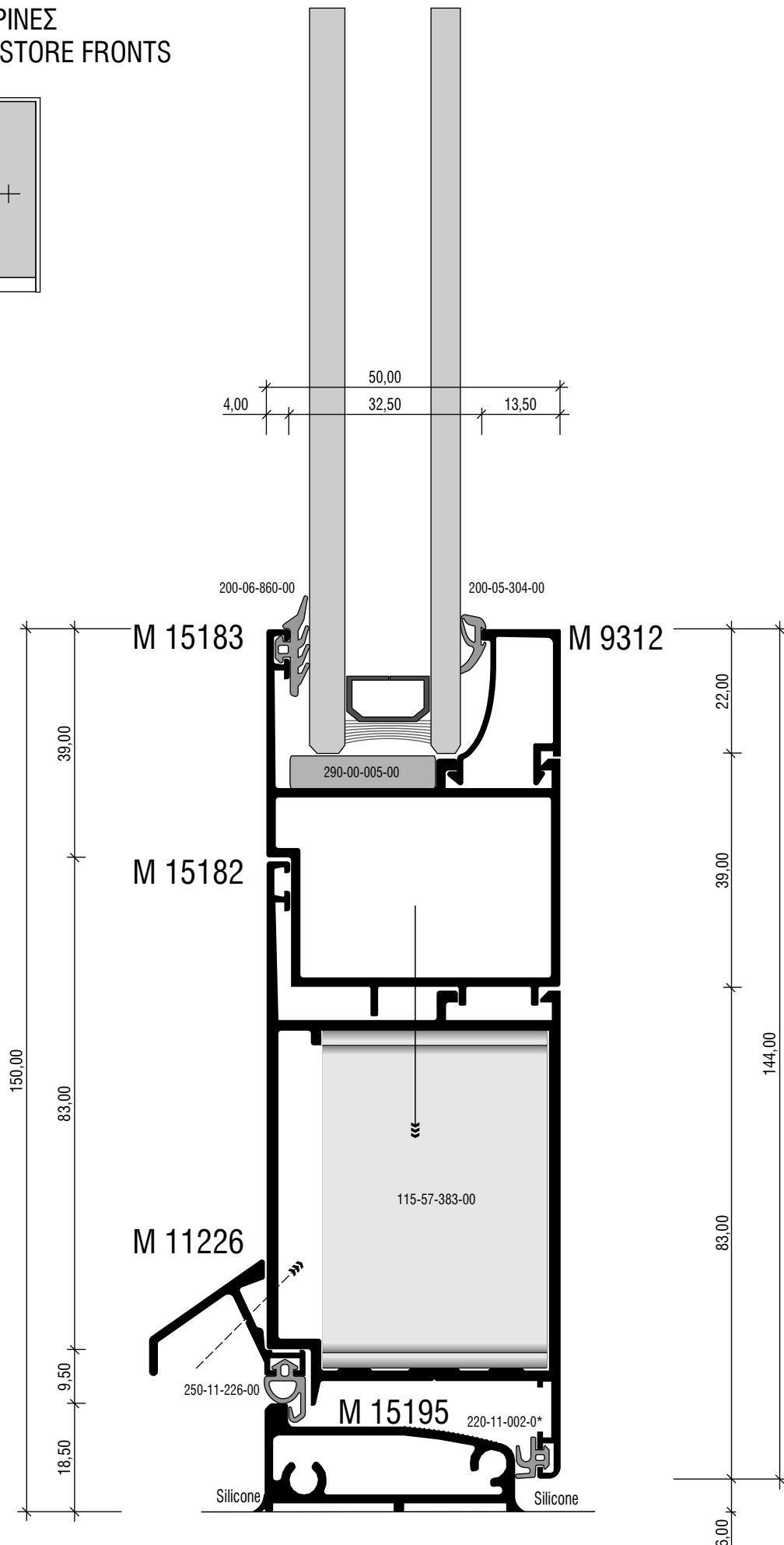
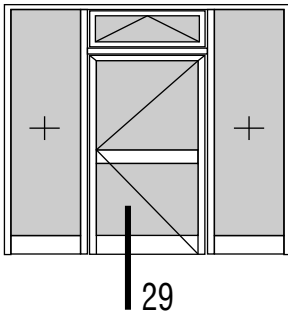

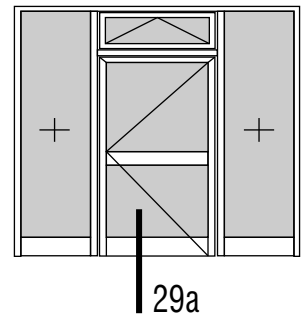
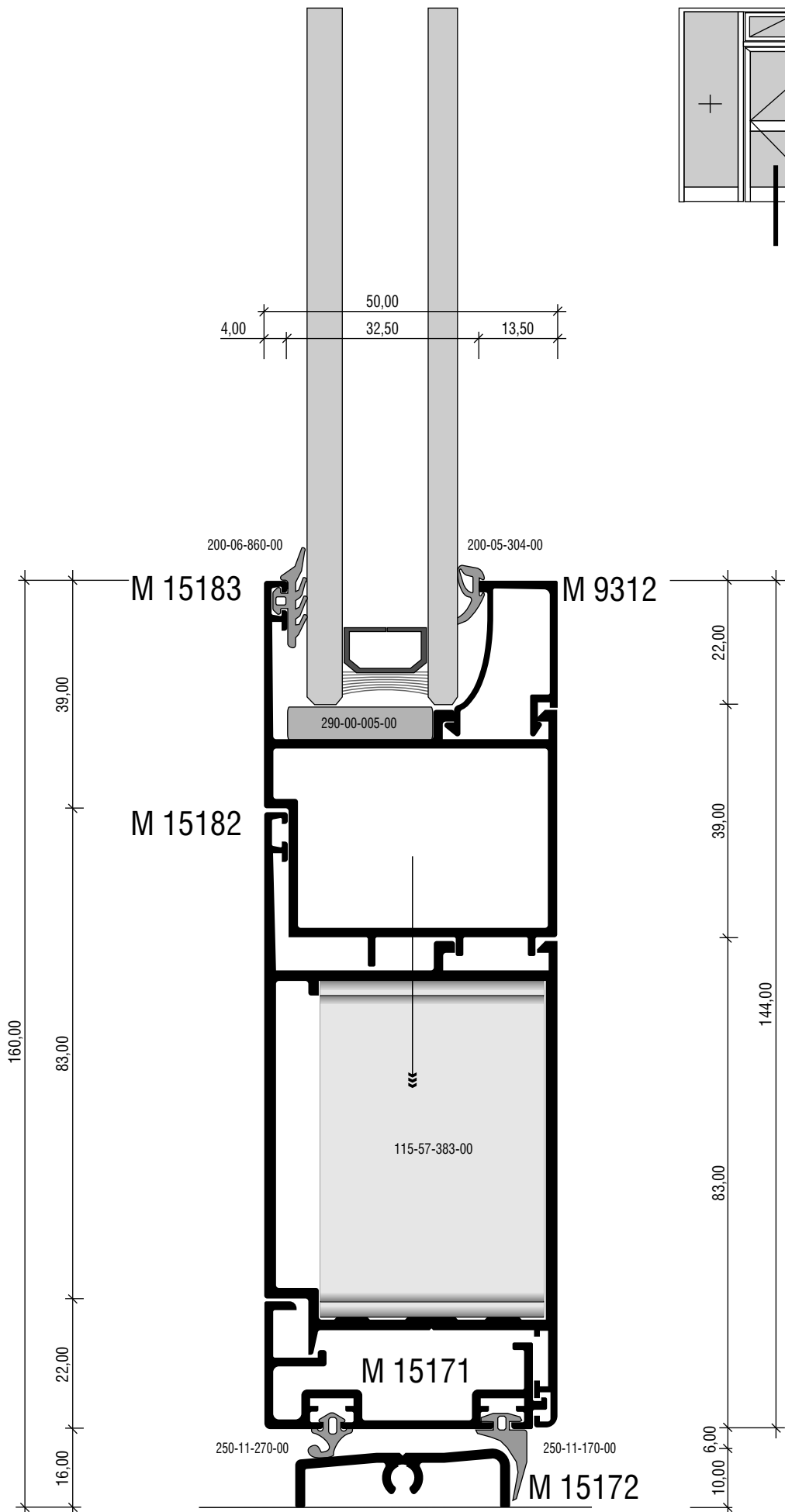

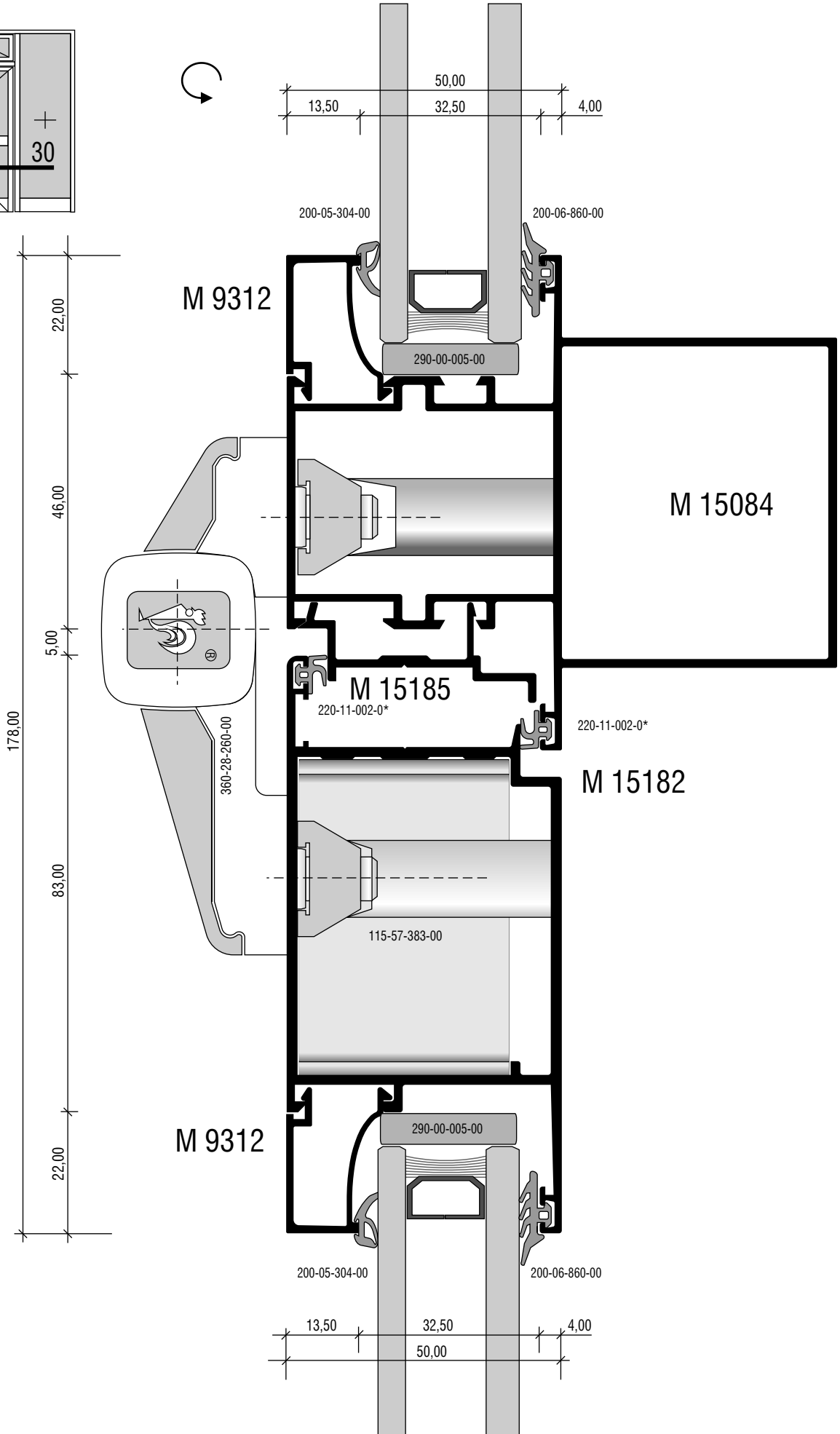
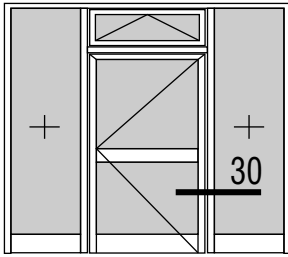

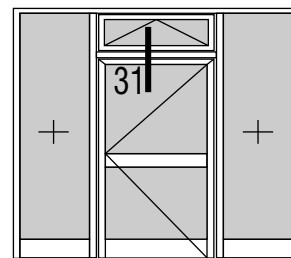
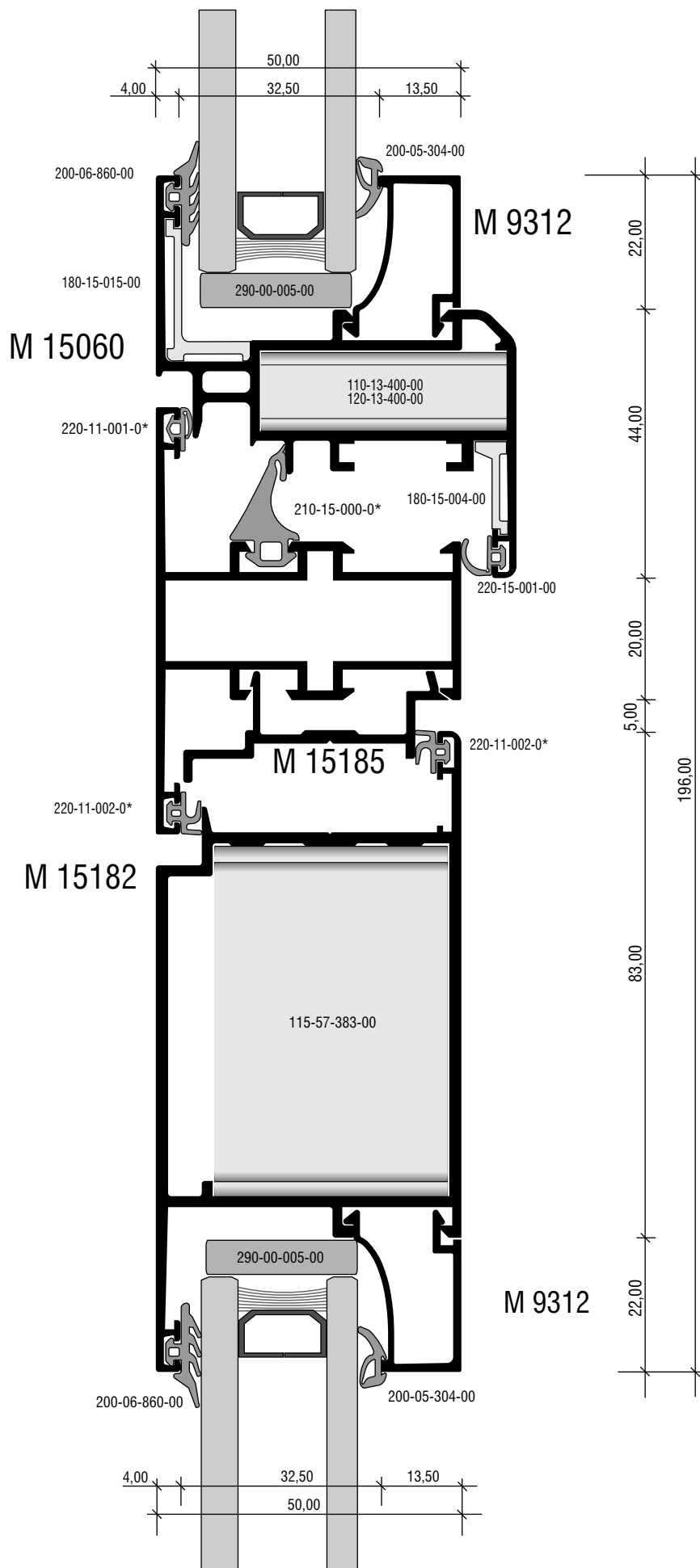

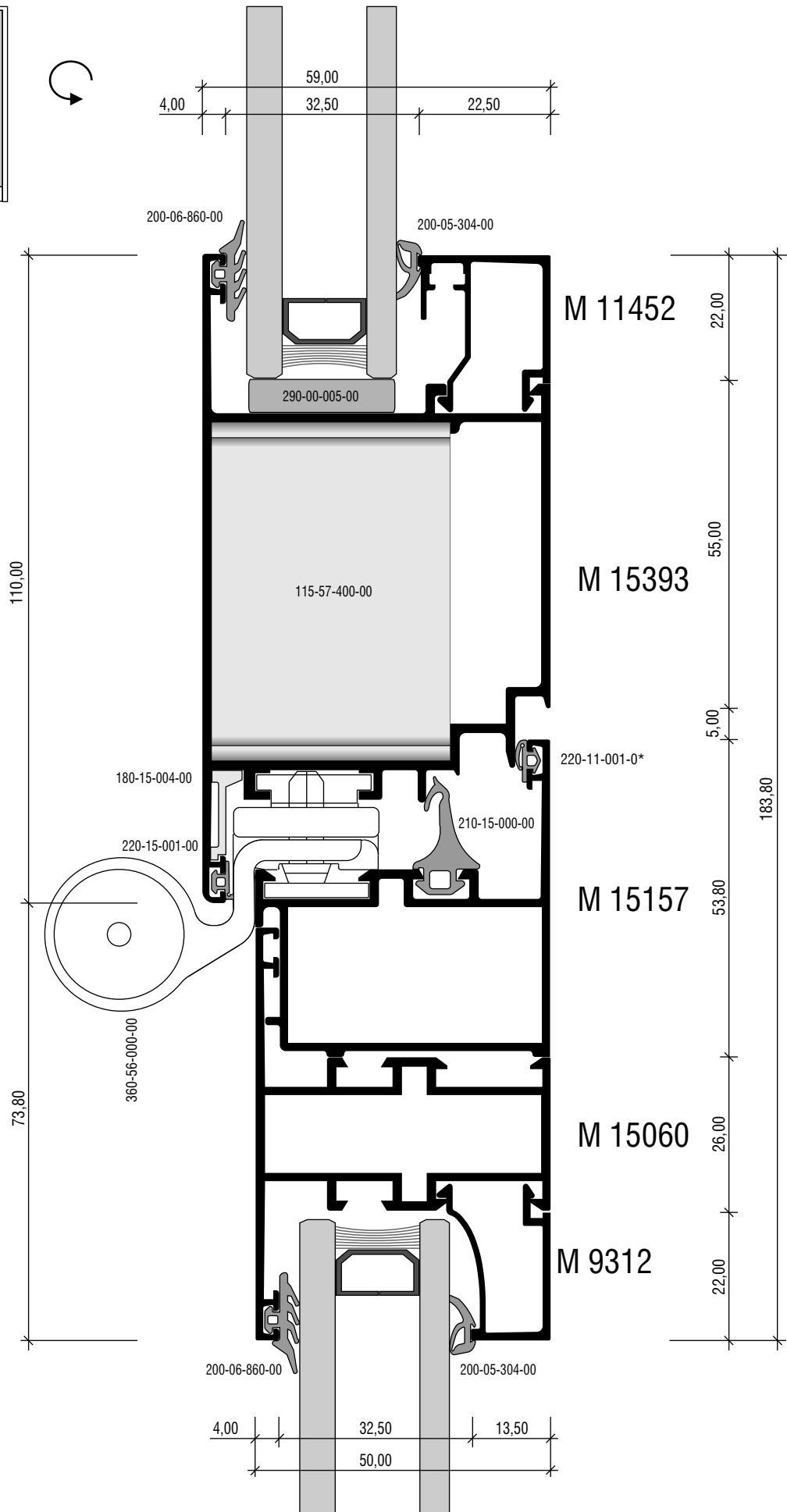
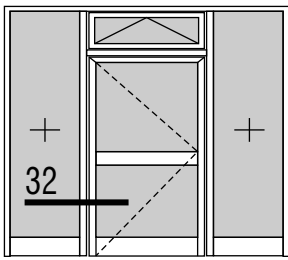

Κοπές - Κατεργασίες Εισόδων
Cutting and Processing Analysis
for main Entrances

ΜΟΝΟΦΥΛΛΟ ΑΝΟΙΓΟΜΕΝΟ ΠΡΟΣ ΤΑ ΜΕΣΑ / SINGLE SASH OPENING IN

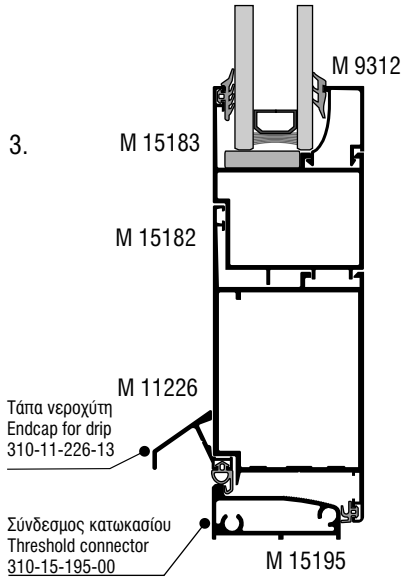
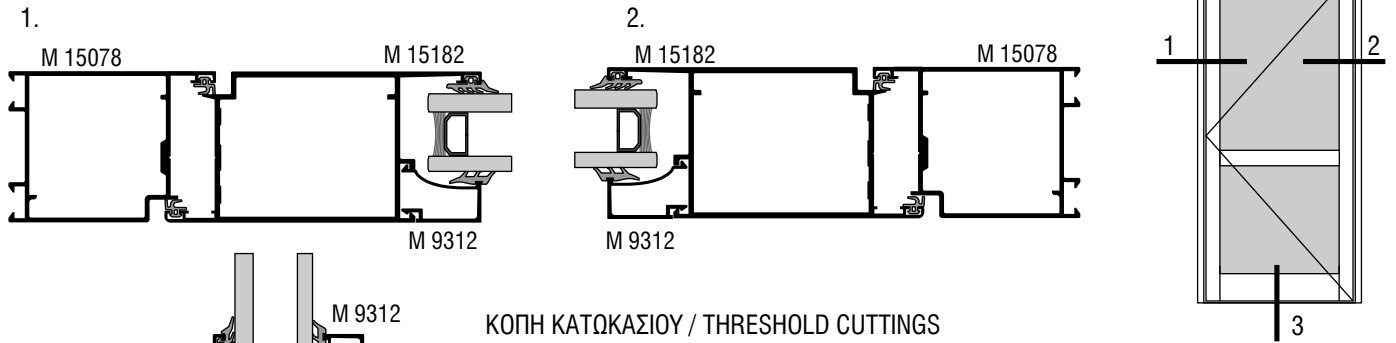

ΚΟΠΗ ΚΑΤΩΚΑΣΙΟΥ / THRESHOLD CUTTINGS

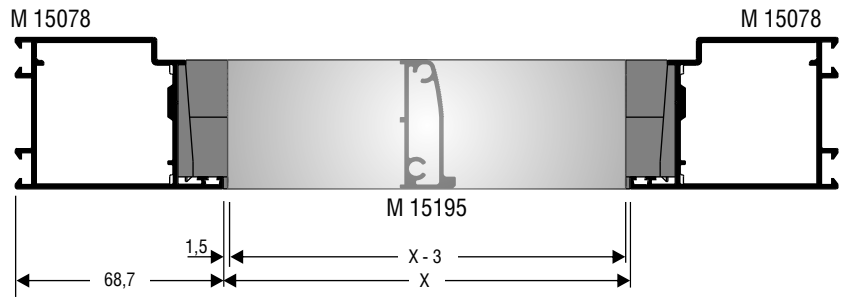

Τάπα νεροχύτη
και στεγανωτικό φύλλο
Endcap for drip cill 310-11-226-13
and sash sealant 310-15-076-03

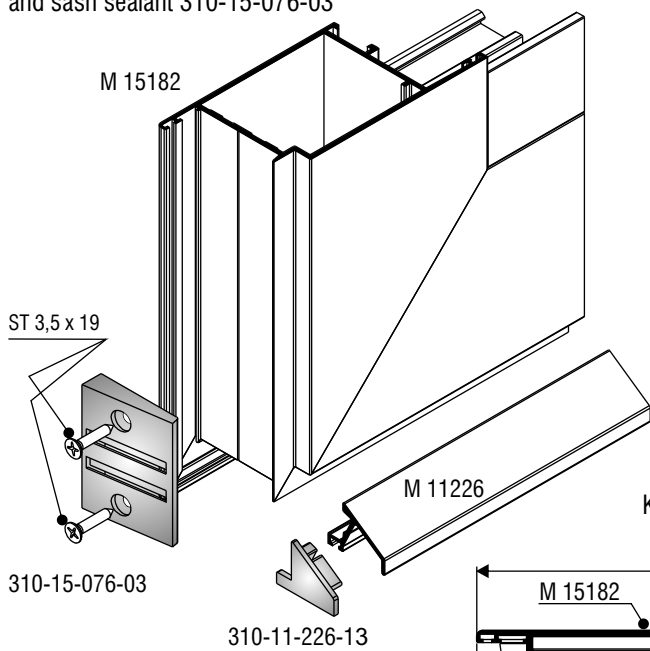

Σύνδεσμος κατωκασίου
Threshold connector
310-15-195-00

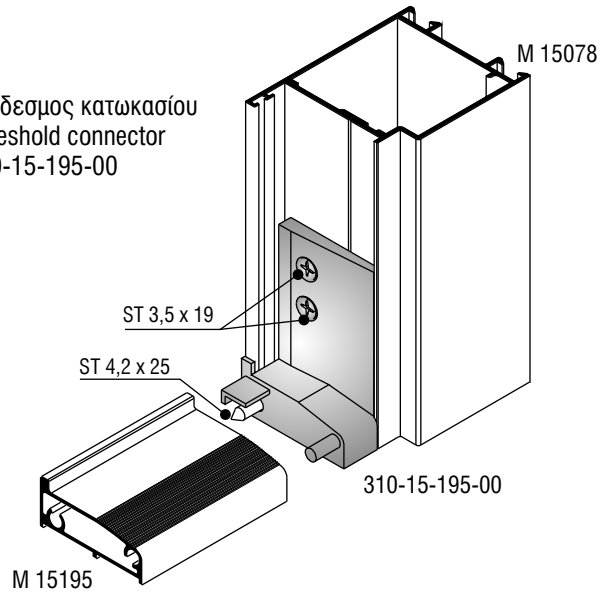

ΚΟΠΗ ΝΕΡΟΧΥΤΗ / DRIP PROFILE CUTTINGS

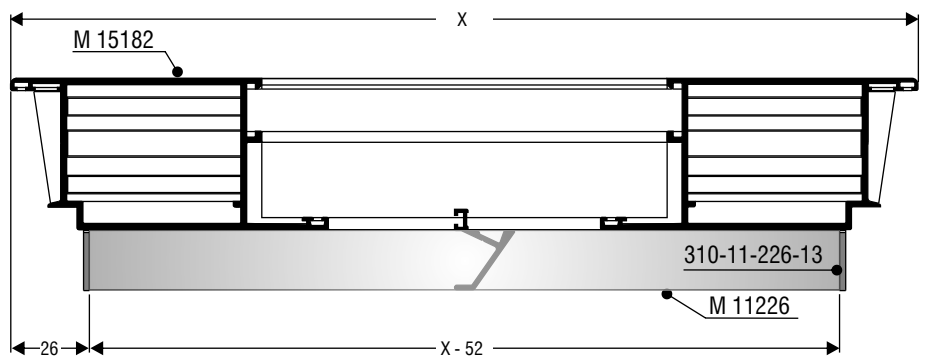

ΔΙΦΥΛΛΟ ΑΝΟΙΓΜΕΝΟ ΠΡΟΣ ΤΑ ΜΕΣΑ / DOUBLE SASH OPENING IN

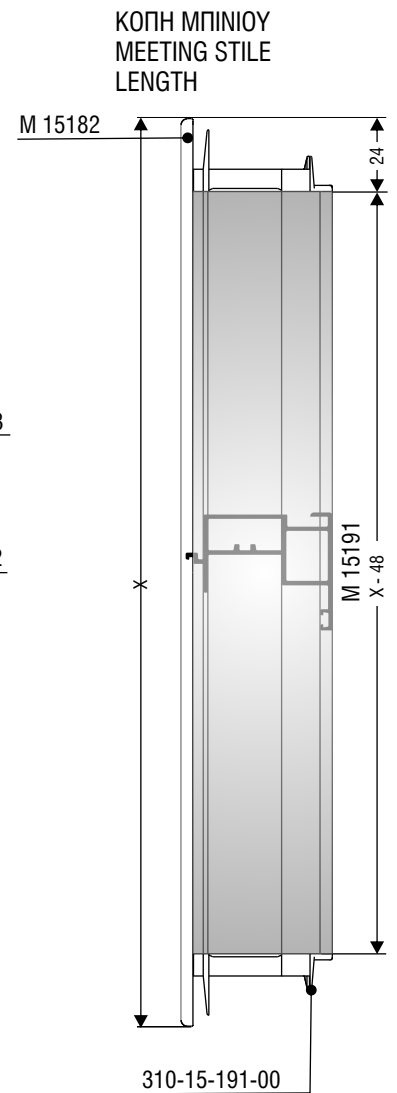
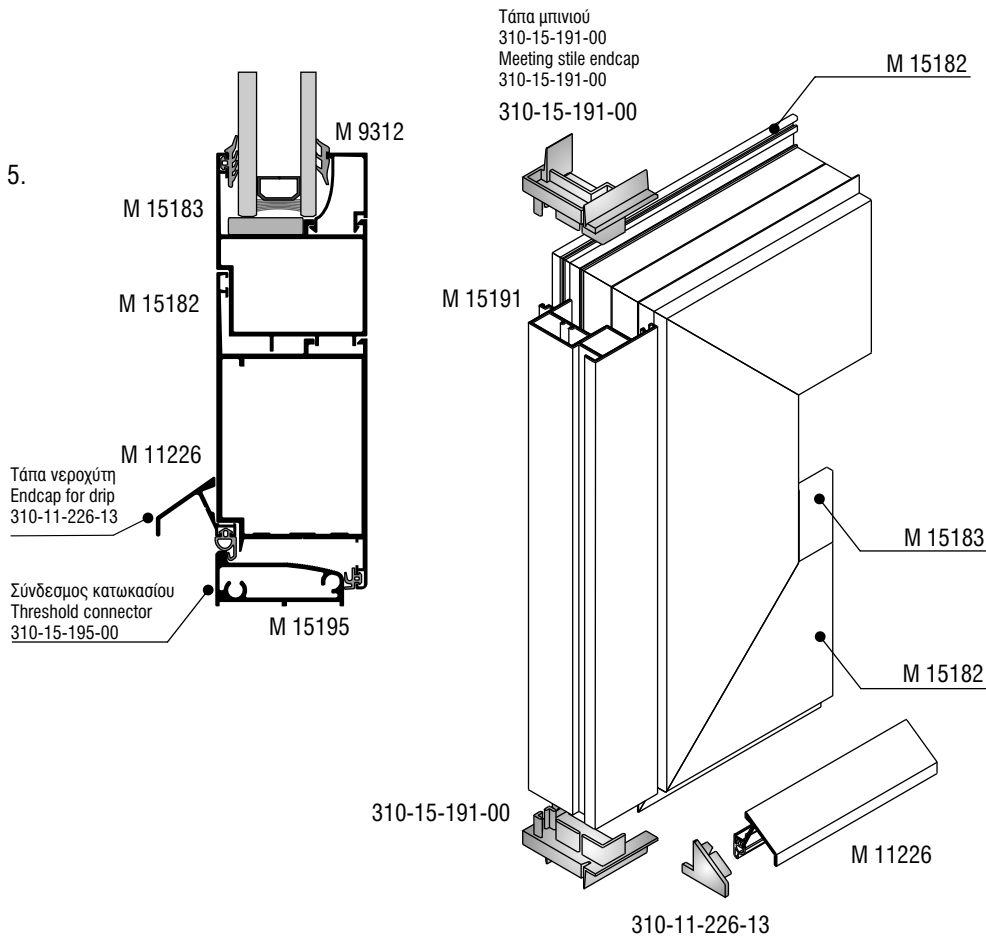
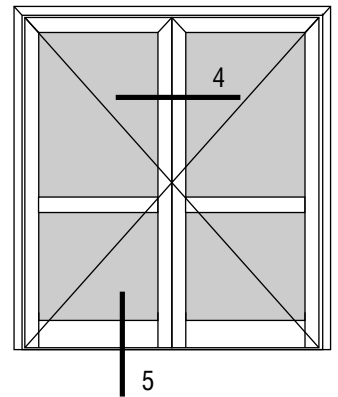
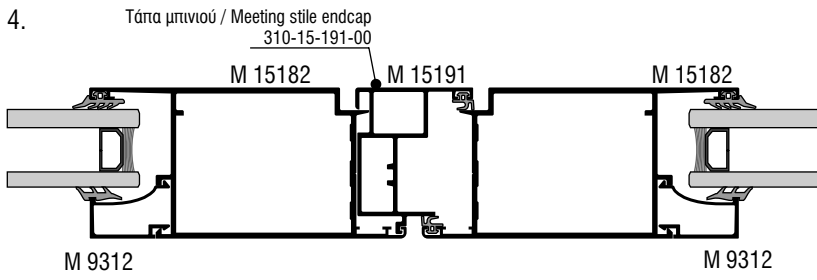

ΚΟΠΗ ΝΕΡΟΧΥΤΗ / DRIP PROFILE CUTTINGS

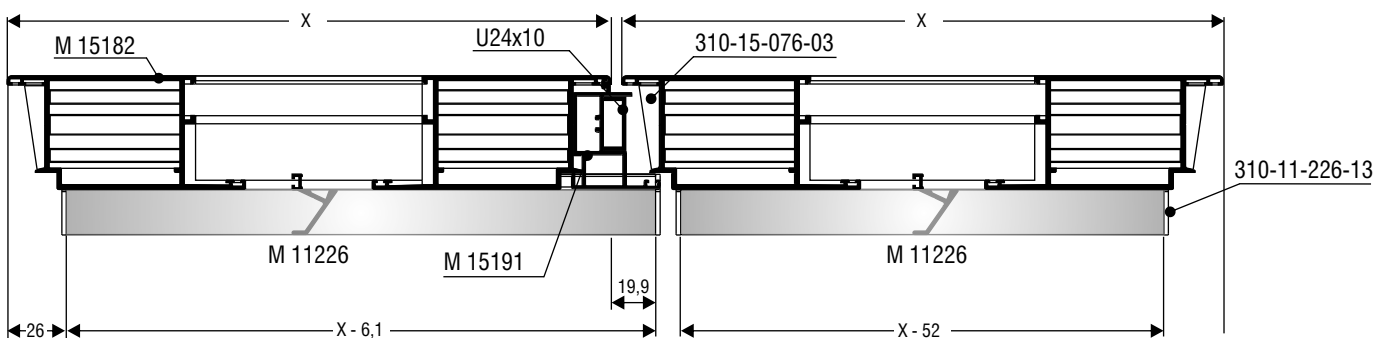

ΜΟΝΟΦΥΛΛΟ ΑΝΟΙΓΟΜΕΝΟ ΠΡΟΣ ΤΑ ΜΕΣΑ / SINGLE SASH OPENING IN

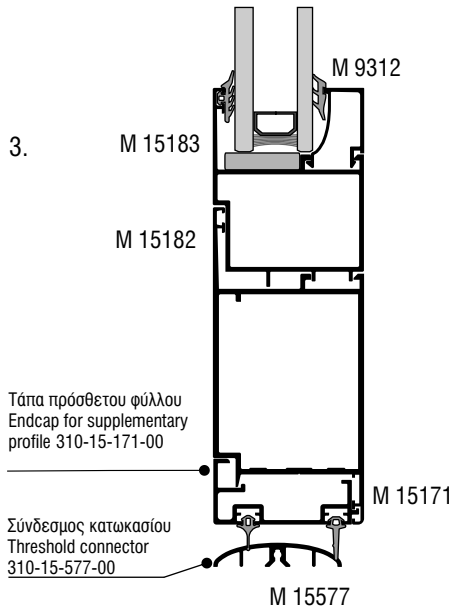
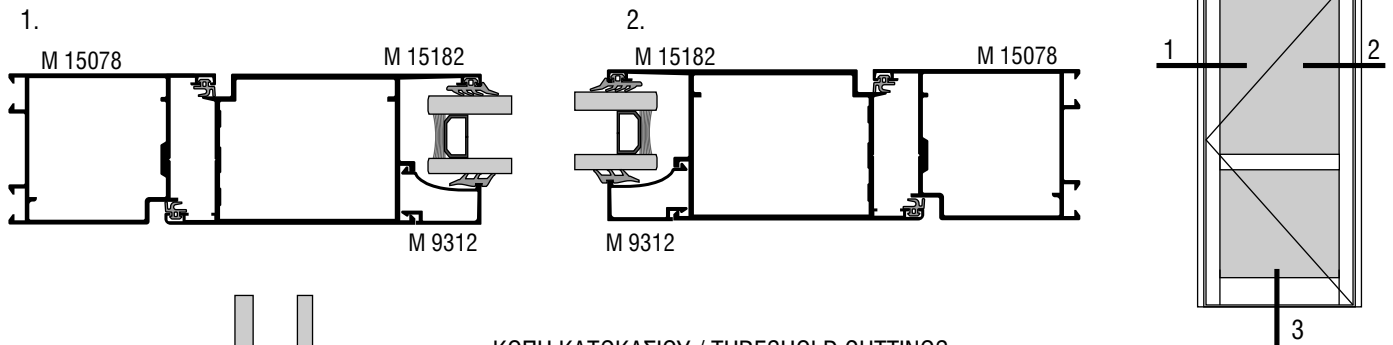

ΚΟΠΗ ΚΑΤΩΚΑΣΙΟΥ / THRESHOLD CUTTINGS

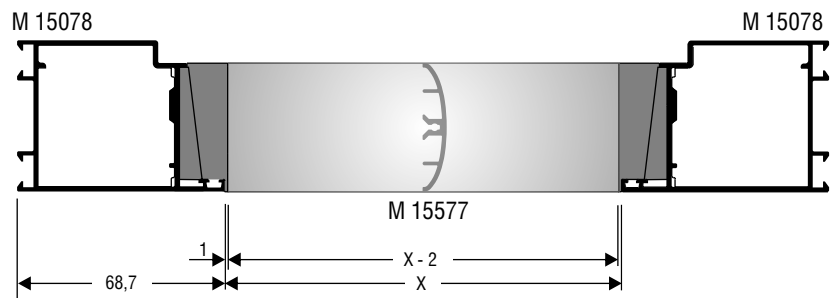

Σύνδεσμος κατωκασίου Threshold connector 310-15-577-00

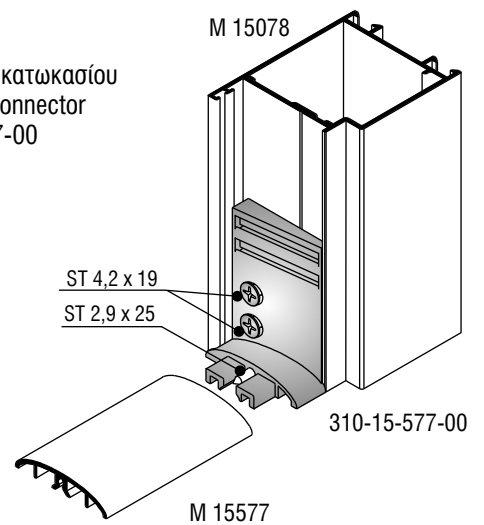

Τάπα πρόσθετου φύλλου και στεγανωτικό φύλλο Endcap for supplementary profile 310-15-171-00 and sash sealant 310-15-076-03

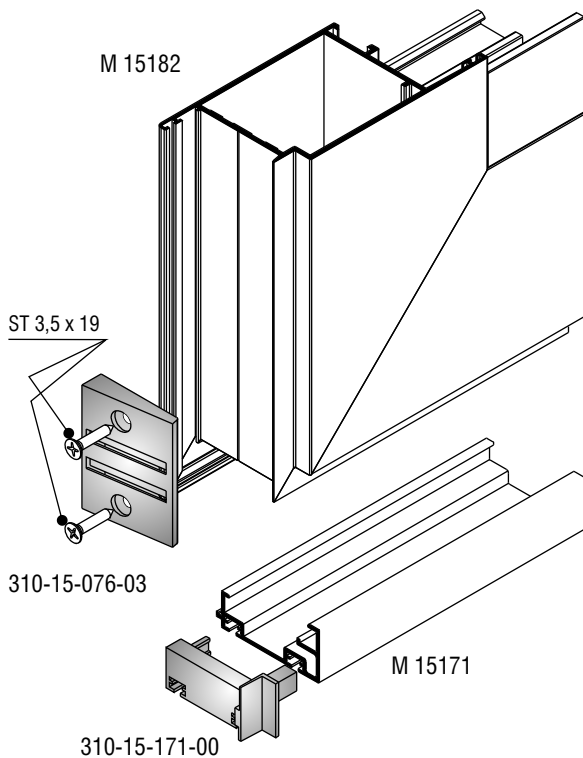

ΚΟΠΗ ΠΡΟΣΘΕΤΟΥ ΦΥΛΛΟΥ CUTTINGS INSTRUCTIONS FOR SUPPLEMENTARY PROFILE

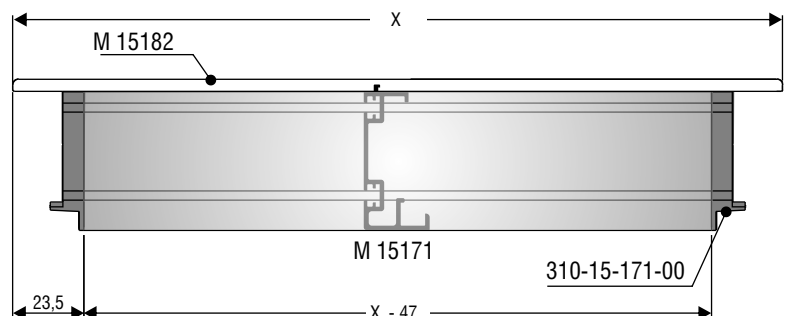

ΔΙΦΥΛΛΟ ΑΝΟΙΓΟΜΕΝΟ ΠΡΟΣ ΤΑ ΜΕΣΑ / DOUBLE SASH OPENING IN

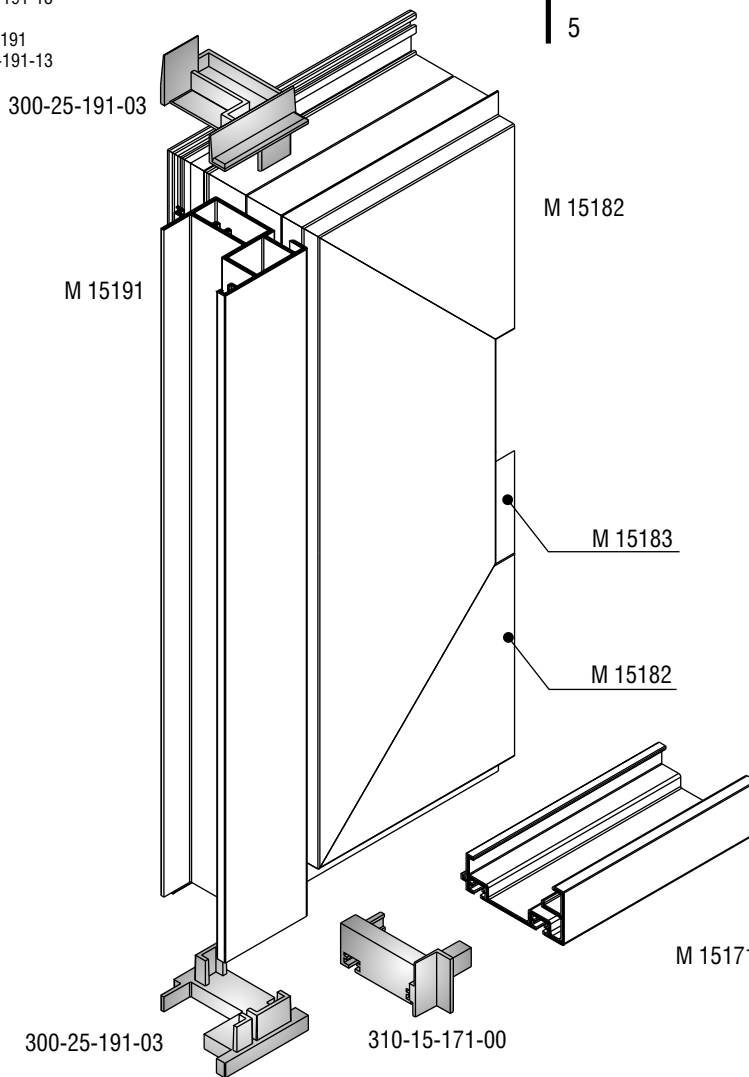
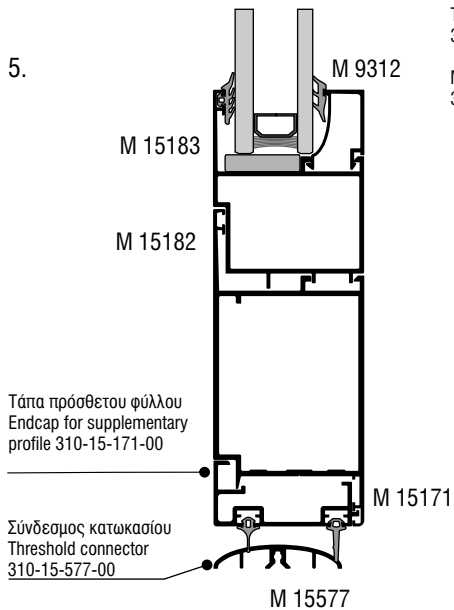
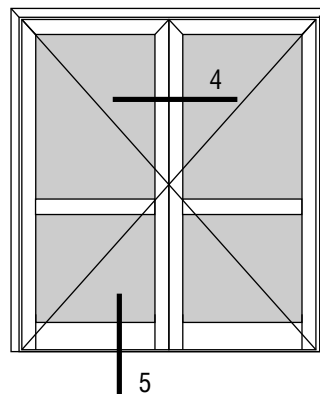
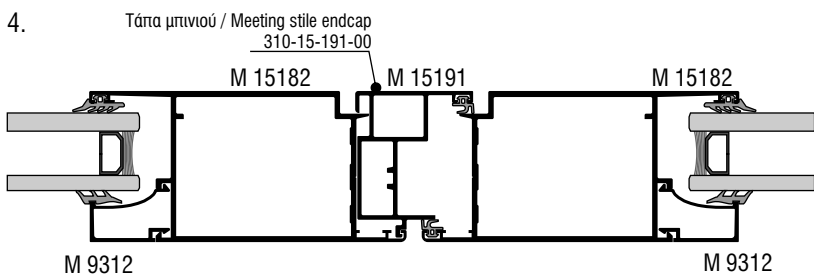

ΚΟΠΗ ΜΠΙΝΙΟΥ MEETING STILE LENGTH

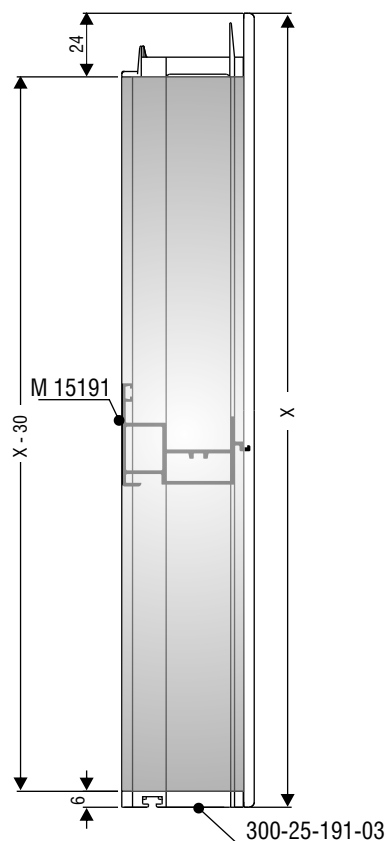

ΚΟΠΗ ΠΡΟΣΘΕΤΟΥ ΦΥΛΛΟΥ CUTTINGS INSTRUCTIONS FOR SUPPLEMENTARY PROFILE

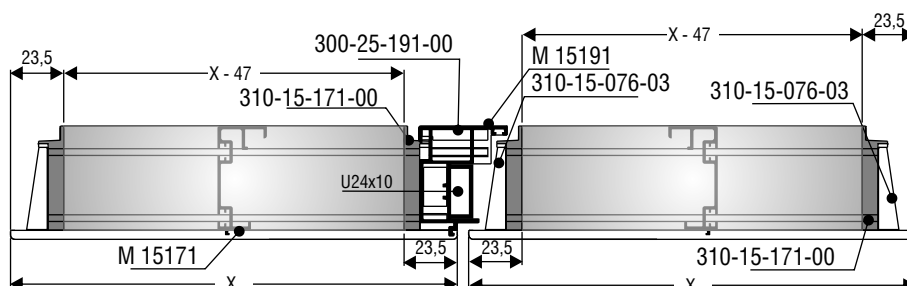

ΜΟΝΟΦΥΛΛΟ ΑΝΟΙΓΟΜΕΝΟ ΠΡΟΣ ΤΑ ΕΞΩ / SINGLE SASH OPENING OUT

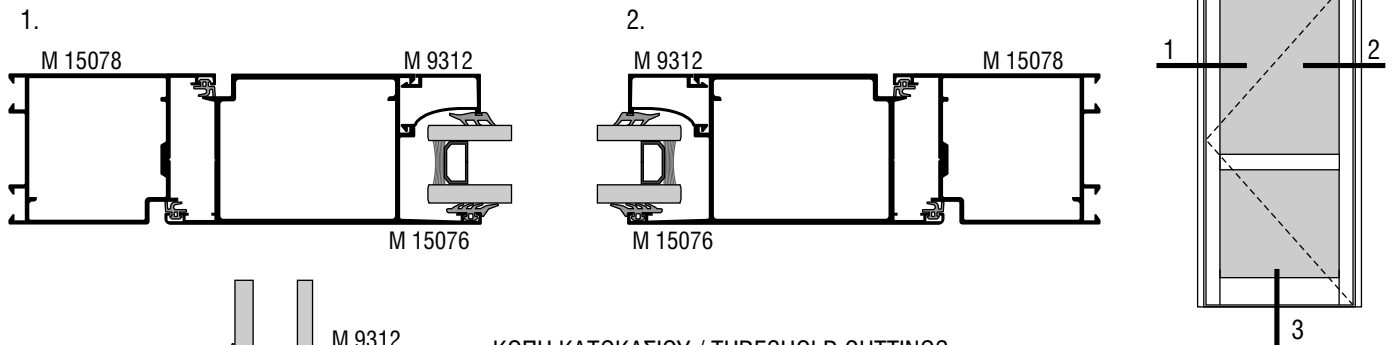

ΚΟΠΗ ΚΑΤΩΚΑΣΙΟΥ / THRESHOLD CUTTINGS

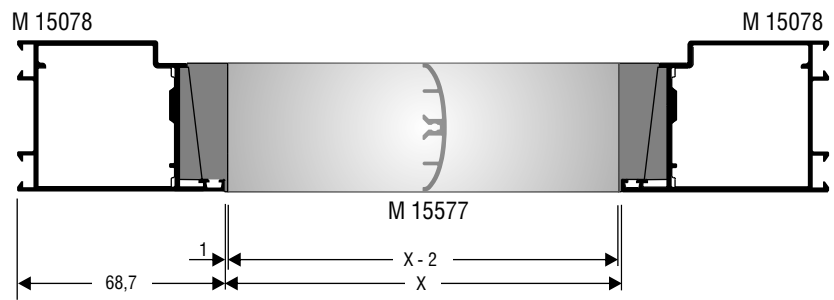

Σύνδεσμος κατωκασίου
Threshold connector
310-15-577-00

Τάπα πρόσθετου φύλλου
και στεγανωτικό φύλλου
Endcap for supplementary profile 310-15-171-00
and sash sealant 310-15-076-03

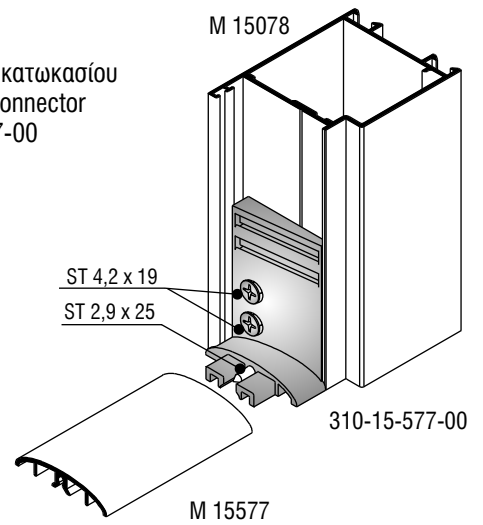
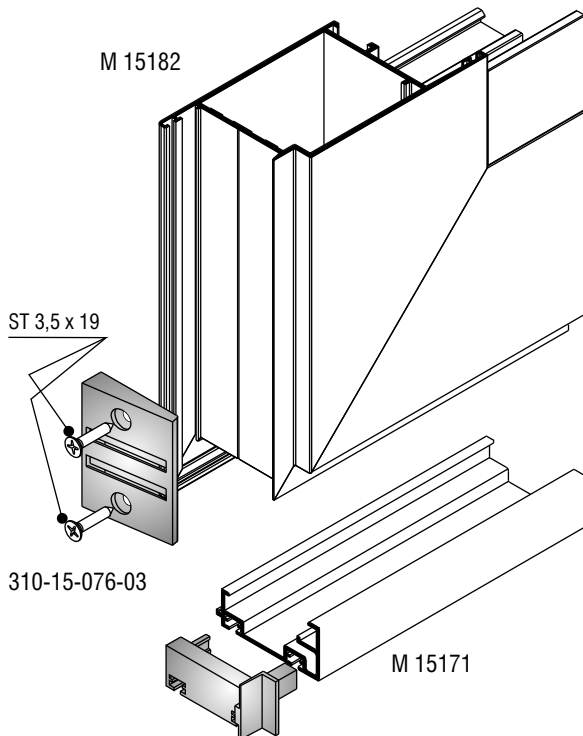

ΚΟΠΗ ΠΡΟΣΘΕΤΟΥ ΦΥΛΛΟΥ CUTTINGS INSTRUCTIONS FOR SUPPLEMENTARY PROFILE

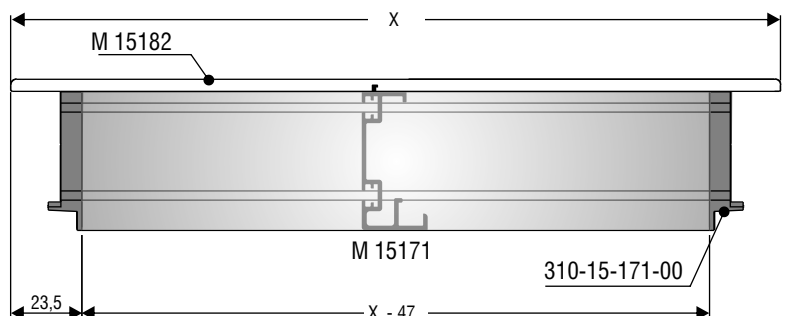

ΔΙΦΥΛΛΟ ΑΝΟΙΓΜΕΝΟ ΠΡΟΣ ΤΑ ΕΞΩ / DOUBLE SASH OPENING OUT

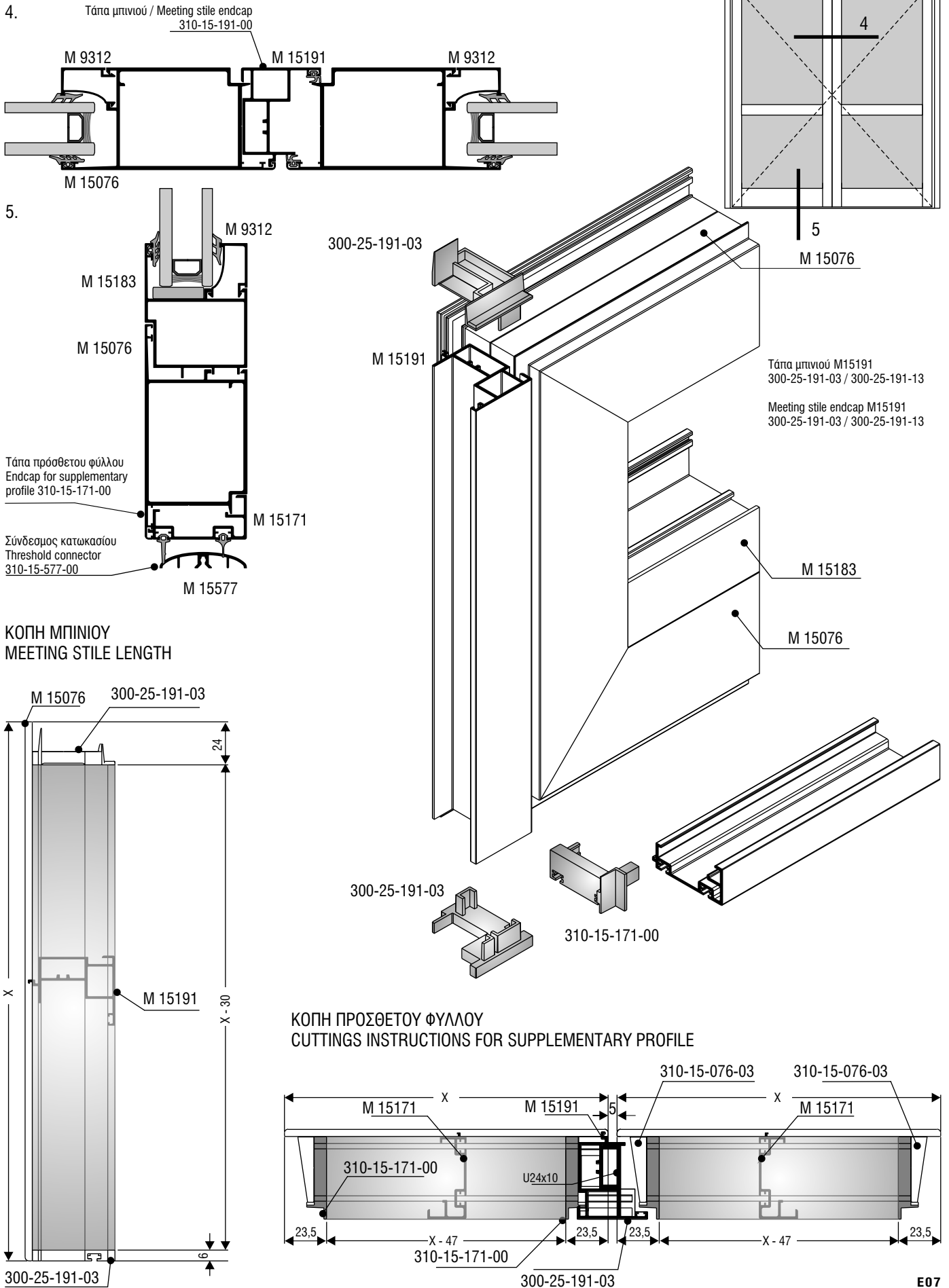

ΜΟΝΟΦΥΛΛΟ ΑΝΟΙΓΟΜΕΝΟ ΠΡΟΣ ΤΑ ΜΕΣΑ / SINGLE SASH OPENING IN

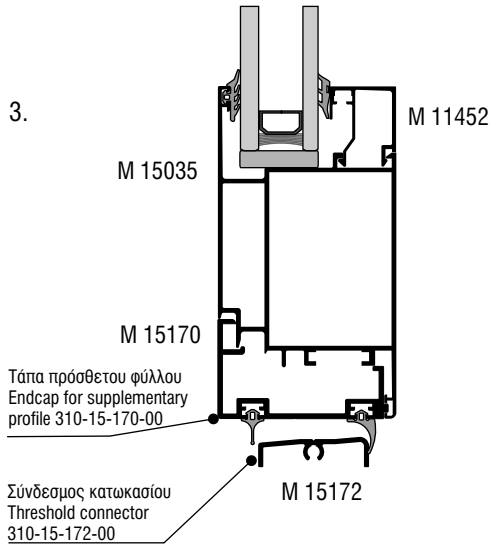
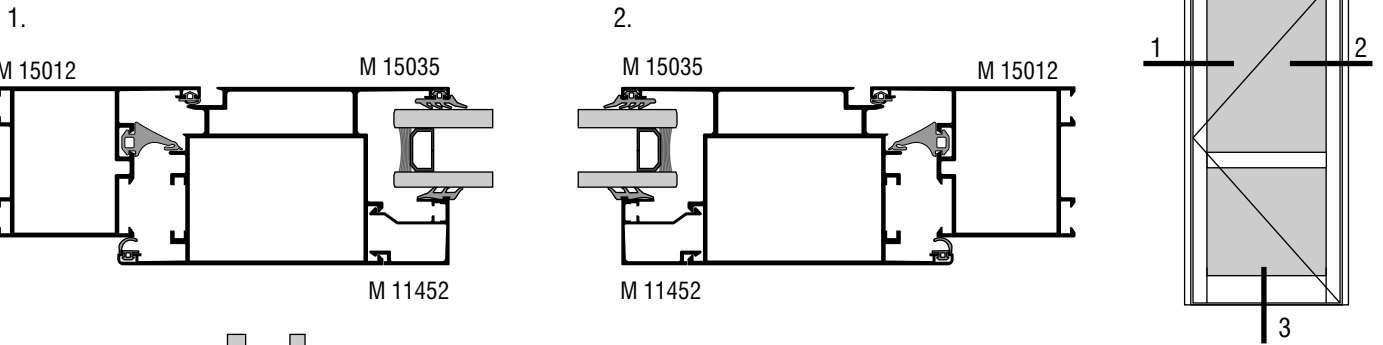

ΚΟΠΗ ΚΑΤΩΚΑΣΙΟΥ / THRESHOLD CUTTINGS

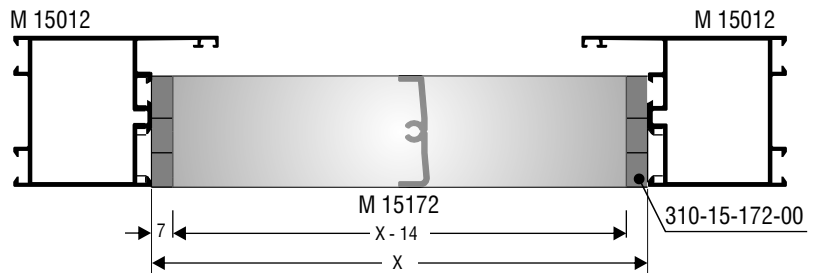

Τάπα πρόσθετου φύλλου
Endcap for supplementary profile
310-15-170-00

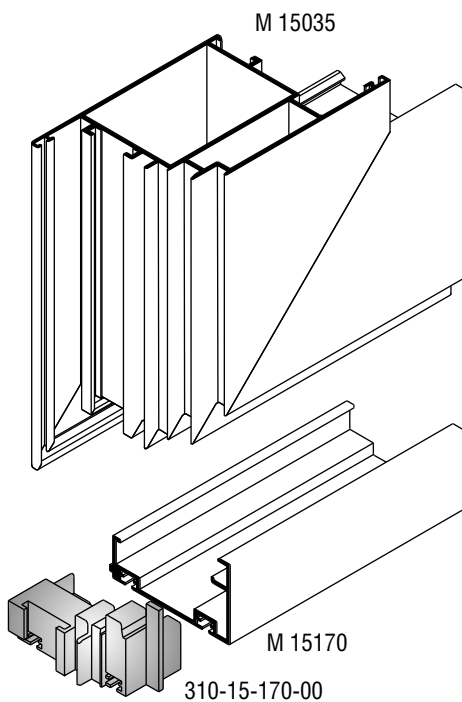

Σύνδεσμος κατωκασίου
Threshold connector
310-15-172-00

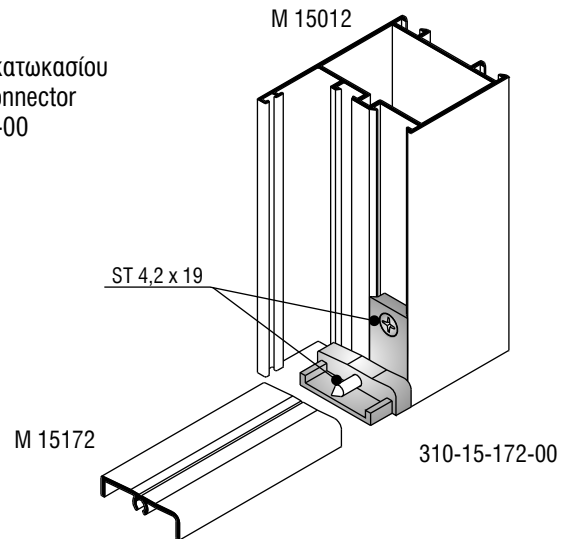

ΚΟΠΗ ΠΡΟΣΘΕΤΟΥ ΦΥΛΛΟΥ CUTTINGS INSTRUCTIONS FOR SUPPLEMENTARY PROFILE

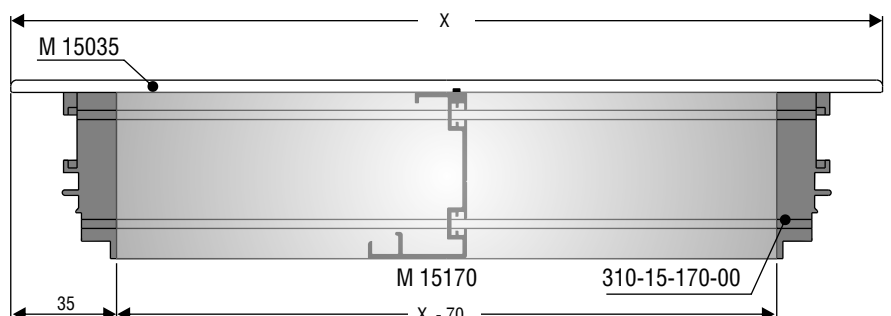

ΔΙΦΥΛΛΟ ΑΝΟΙΓΟΜΕΝΟ ΠΡΟΣ ΤΑ ΜΕΣΑ / DOUBLE SASH OPENING IN

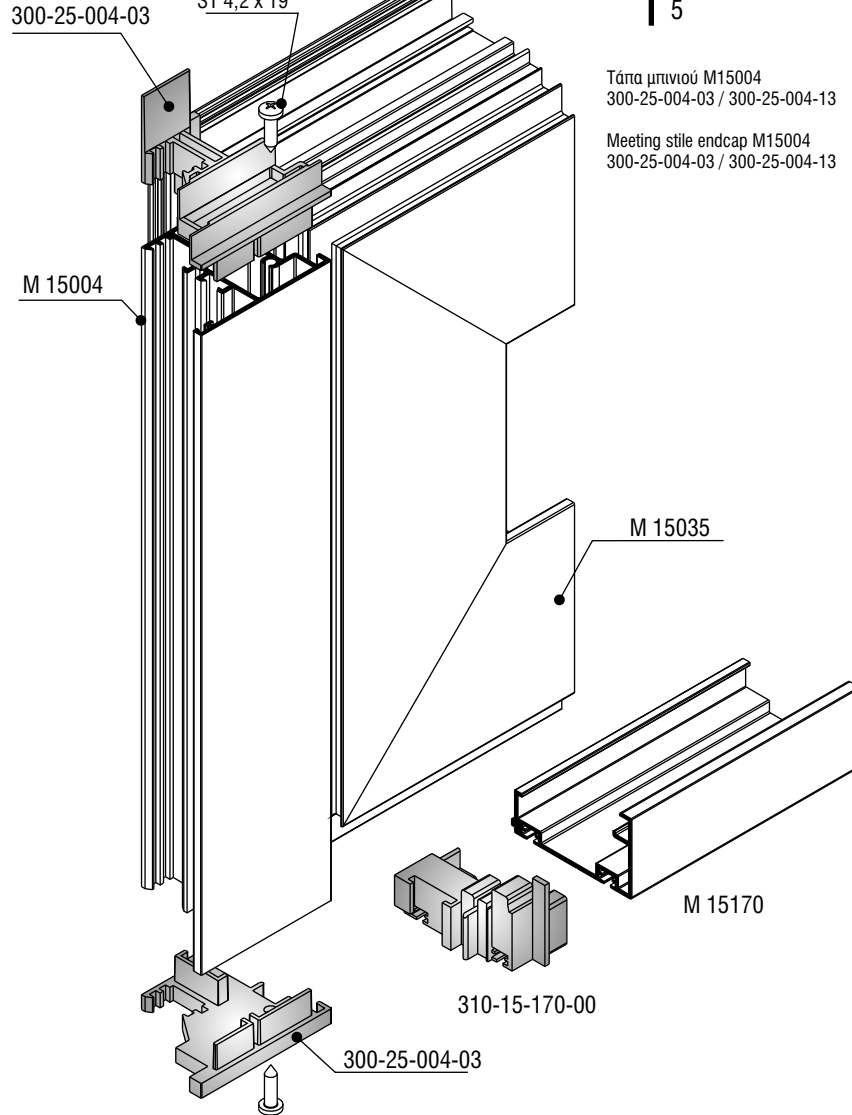
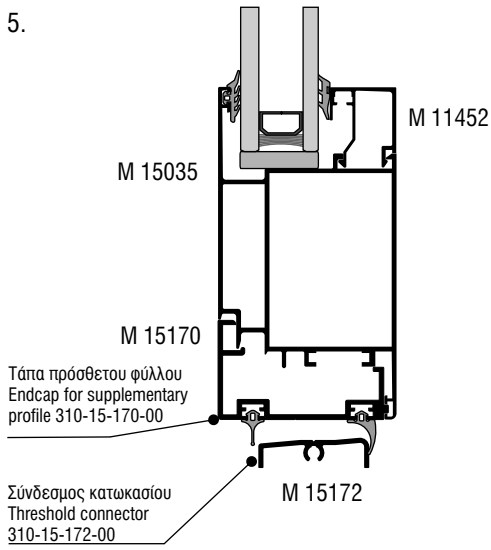
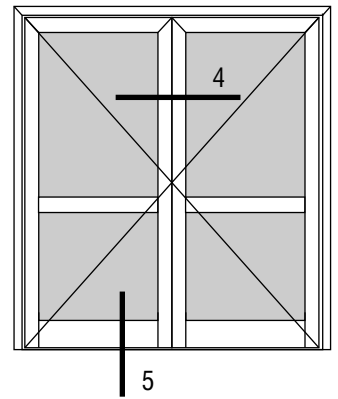
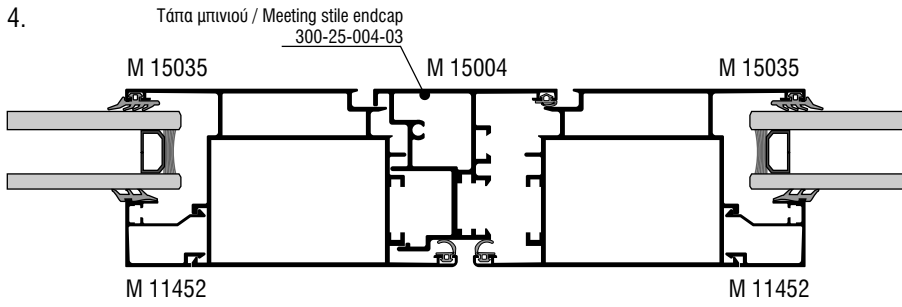

ΚΟΠΗ ΜΠΙΝΙΟΥ MEETING STILE LENGTH

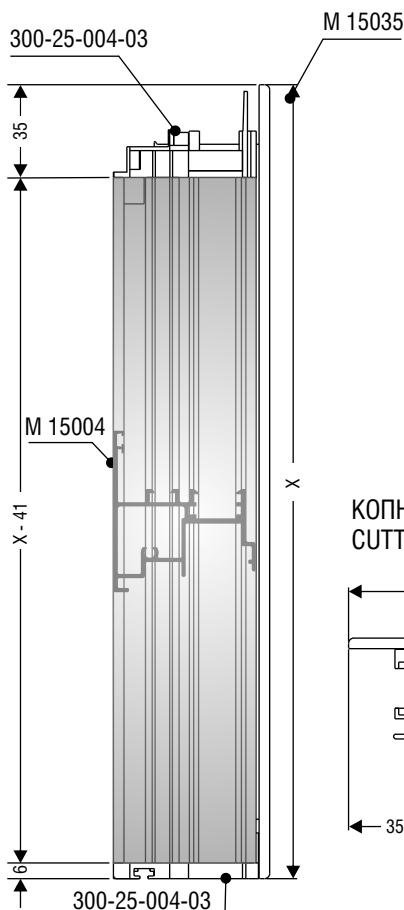

ΚΟΠΗ ΠΡΟΣΘΕΤΟΥ ΦΥΛΛΟΥ CUTTINGS INSTRUCTIONS FOR SUPPLEMENTARY PROFILE

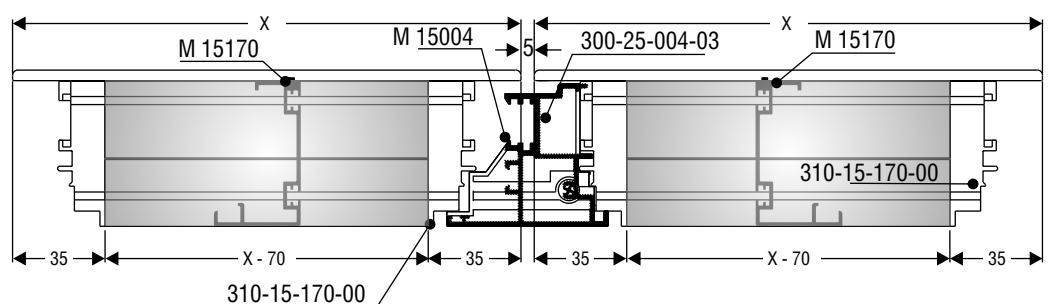

ΜΟΝΟΦΥΛΛΟ ΑΝΟΙΓΟΜΕΝΟ ΠΡΟΣ ΤΑ ΕΞΩ / SINGLE SASH OPENING OUT

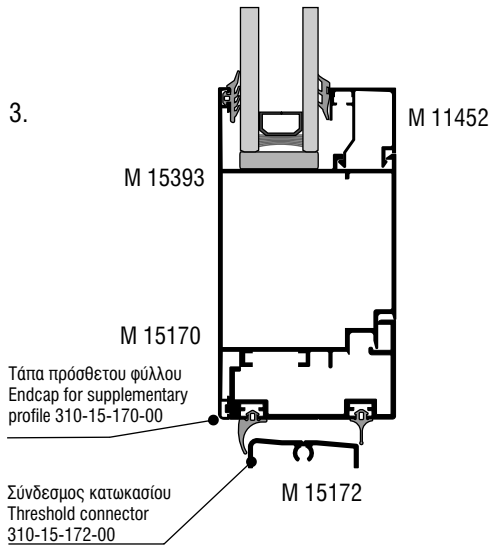
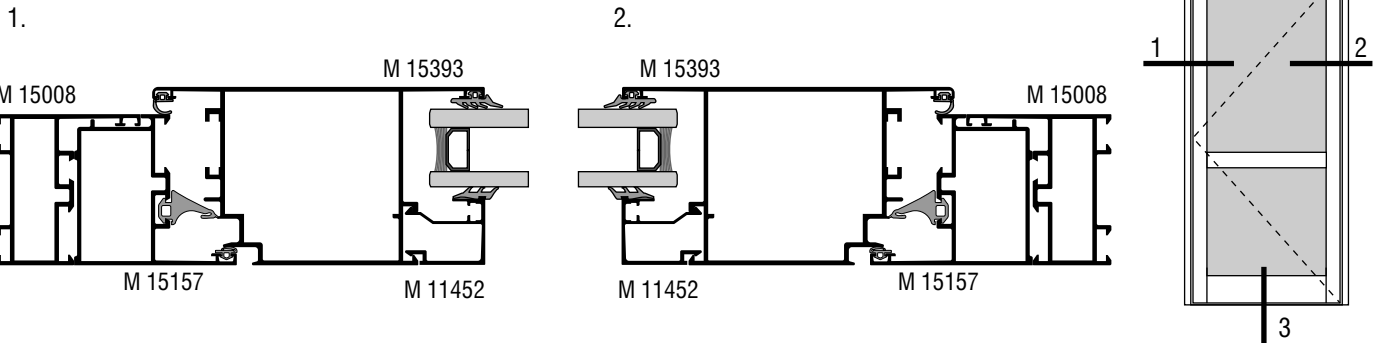

ΚΟΠΗ ΚΑΤΩΚΑΣΙΟΥ / THRESHOLD CUTTINGS

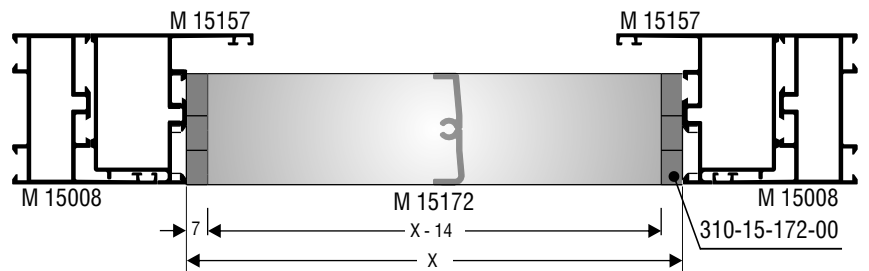

Σύνδεσμος κατωκασίου Threshold connector 310-15-172-00

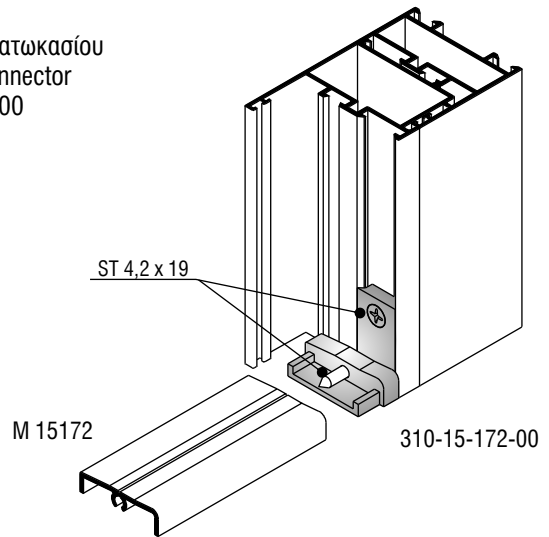

Τάπα πρόσθετου φύλλου Endcap for supplementary profile 310-15-170-00

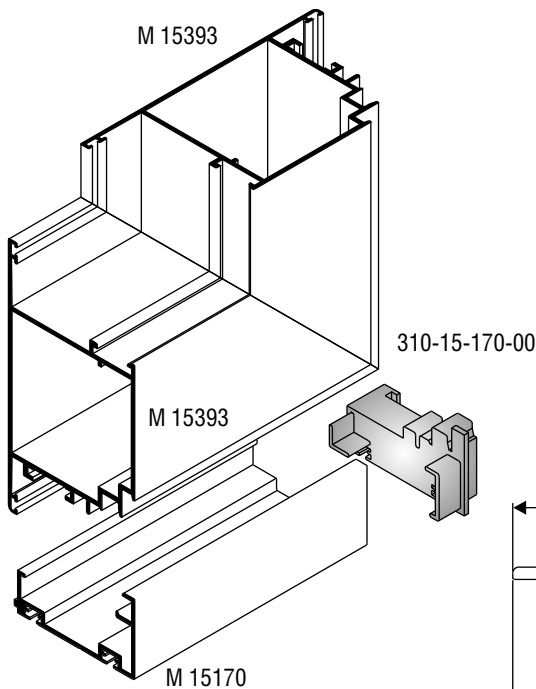

ΚΟΠΗ ΠΡΟΣΘΕΤΟΥ ΦΥΛΛΟΥ CUTTINGS INSTRUCTIONS FOR SUPPLEMENTARY PROFILE

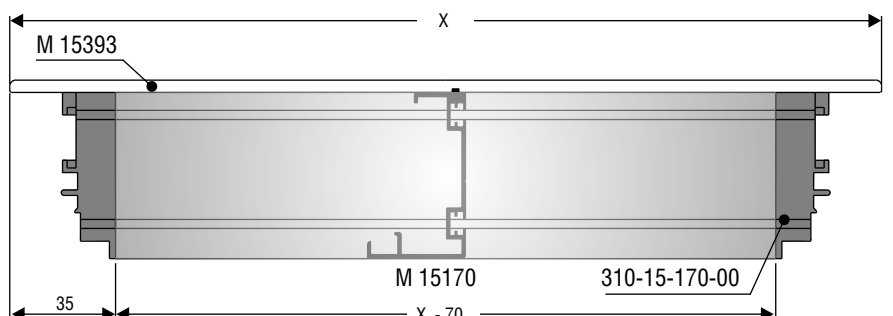

ΔΙΦΥΛΛΟ ΑΝΟΙΓΜΕΝΟ ΠΡΟΣ ΤΑ ΕΞΩ / DOUBLE SASH OPENING OUT

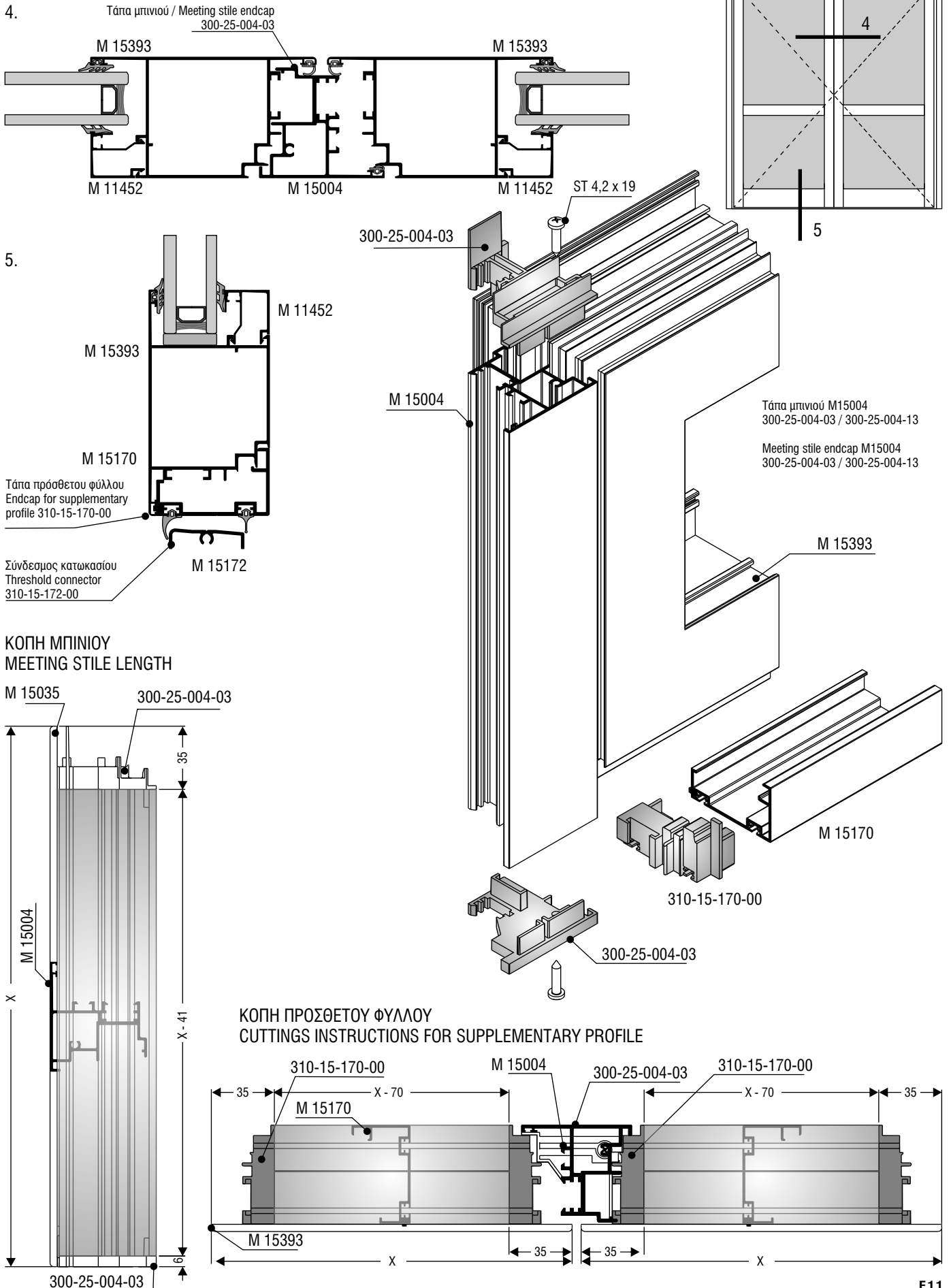

Κοπές
Cutting Analysis

ΜΟΝΟΦΥΛΛΟ ΑΝΟΙΓΟΜΕΝΟ - ΠΡΟΒΑΛΛΟΜΕΝΟ SINGLE LEAF CASEMENT / TILT-N-TURN WINDOW

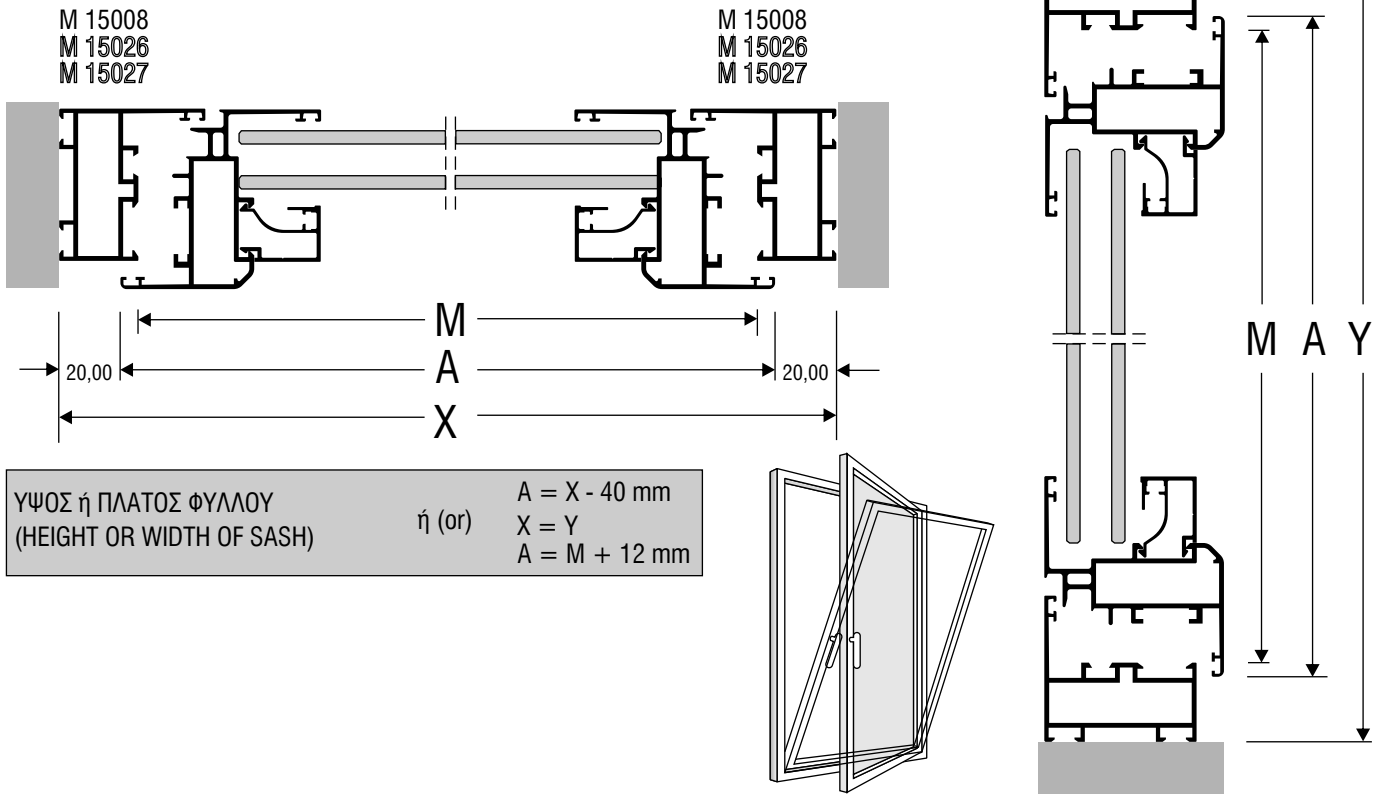

ΔΙΦΥΛΛΟ ΑΝΟΙΓΟΜΕΝΟ - ΠΡΟΒΑΛΛΟΜΕΝΟ DOUBLE LEAF CASEMENT / TILT-N-TURN WINDOW

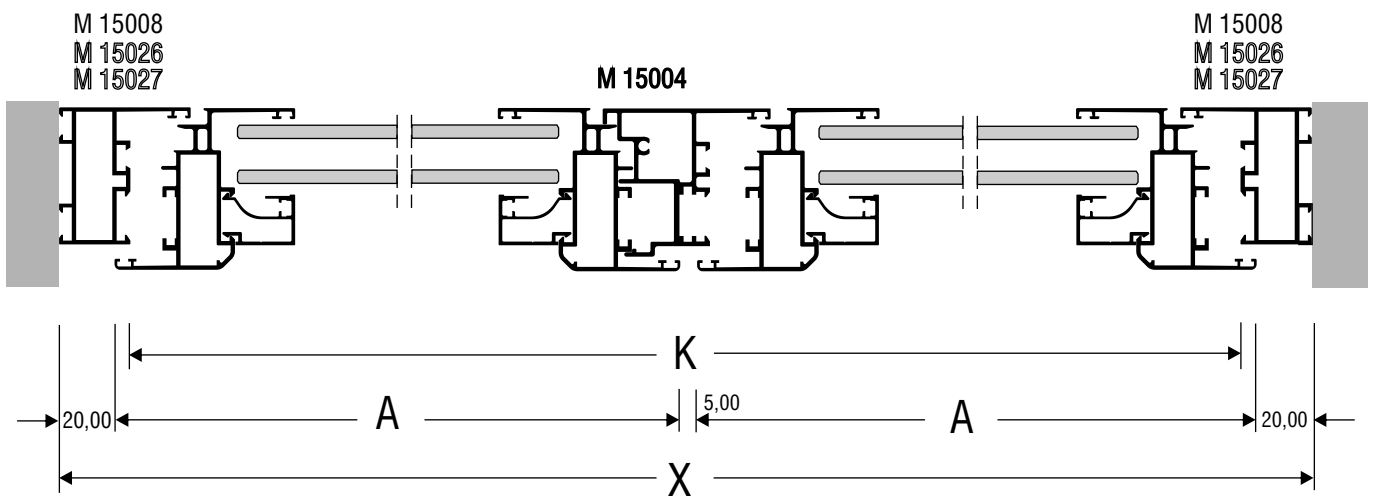

ΠΛΑΤΟΣ ΦΥΛΛΟΥ
(WIDTH OF SASH)

$A = \frac{X - 45}{2} \text{ mm}$ ή (or) $A = \frac{K + 7}{2} \text{ mm}$

ΥΨΟΣ ΦΥΛΛΟΥ
(HEIGHT OF SASH)

$A = Y - 40 \text{ mm}$ ή (or) $A = M + 12 \text{ mm}$

ΜΟΝΟΦΥΛΛΟ ΑΝΟΙΓΟΜΕΝΟ - ΠΡΟΒΑΛΛΟΜΕΝΟ
SINGLE LEAF CASEMENT / TILT-N-TURN WINDOW

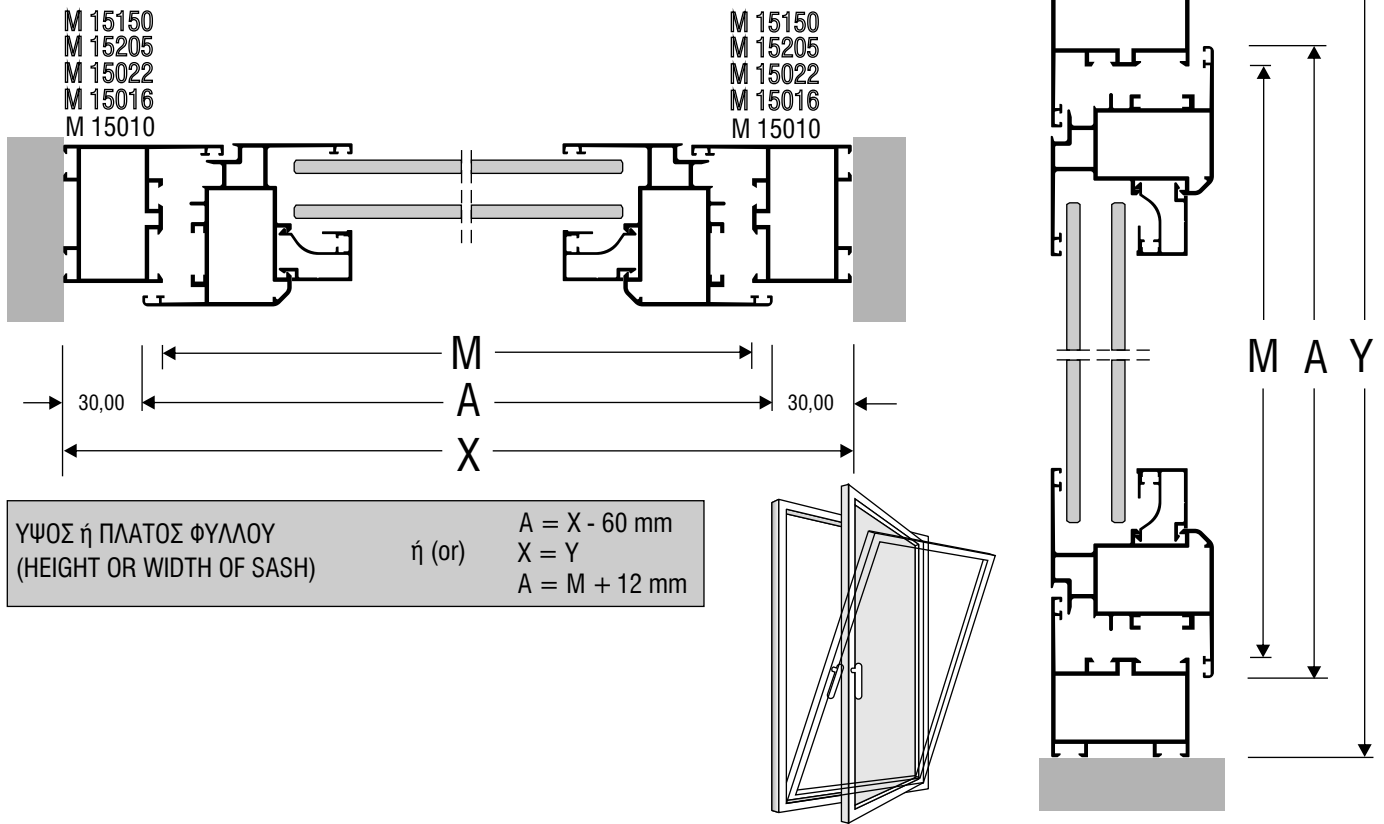

ΔΙΦΥΛΛΟ ΑΝΟΙΓΟΜΕΝΟ - ΠΡΟΒΑΛΛΟΜΕΝΟ
DOUBLE LEAF CASEMENT / TILT-N-TURN WINDOW

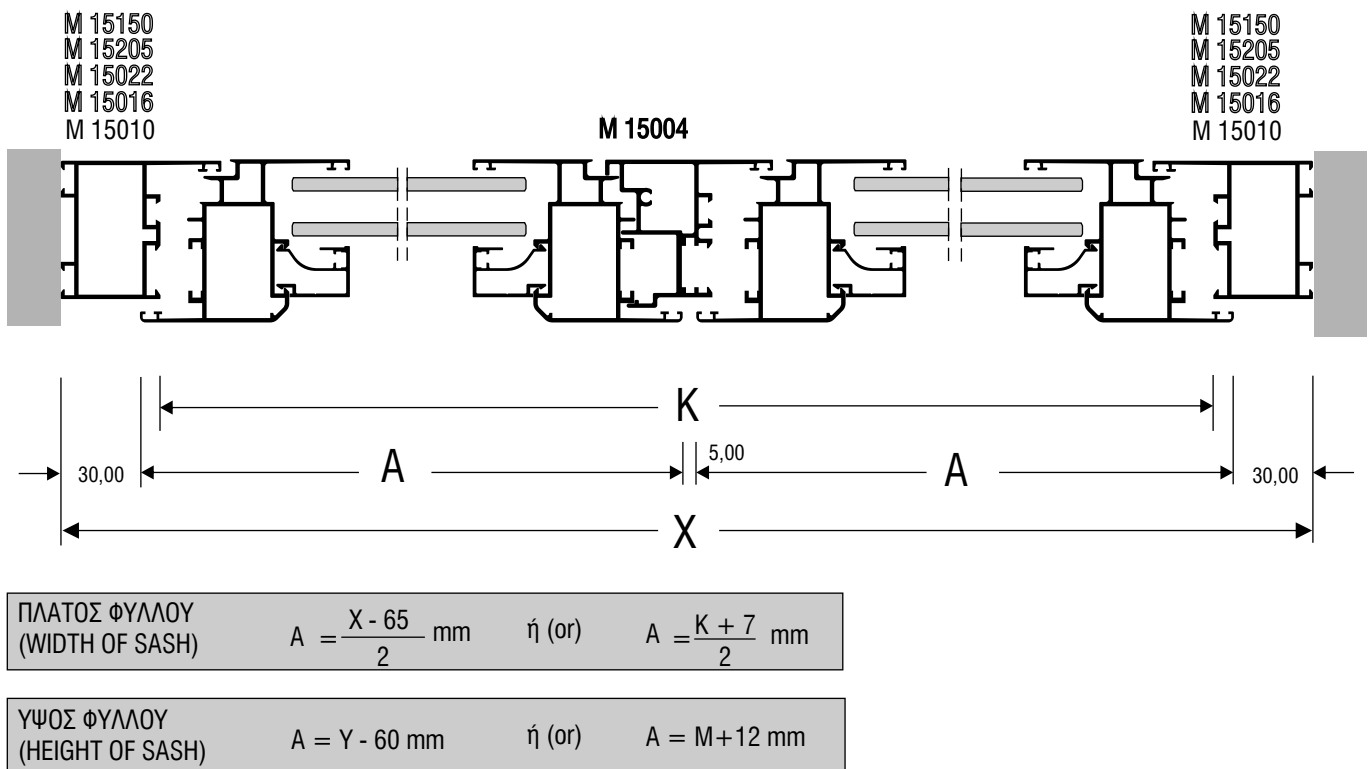

ΜΟΝΟΦΥΛΛΟ ΑΝΟΙΓΟΜΕΝΟ - ΠΡΟΒΑΛΛΟΜΕΝΟ
SINGLE LEAF CASEMENT / TILT-N-TURN WINDOW

M 15024
M 15018
M 15012

M 15024
M 15018
M 15012

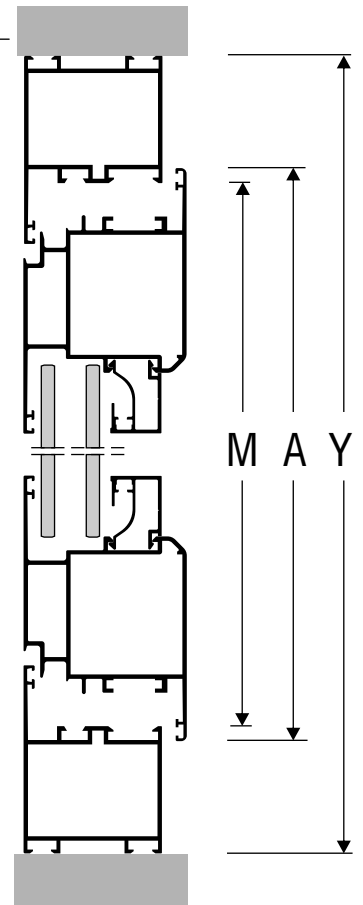
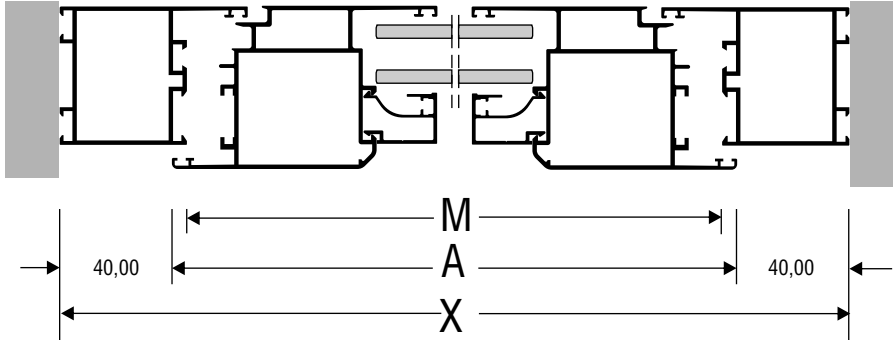

ΥΨΟΣ ή ΠΛΑΤΟΣ ΦΥΛΛΟΥ
(HEIGHT OR WIDTH OF SASH)

ή (or)

$$A = X - 80 \text{ mm}$$

$$X = Y$$

$$A = M + 12 \text{ mm}$$

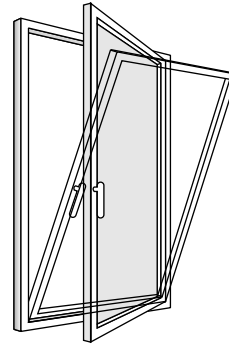

ΔΙΦΥΛΛΟ ΑΝΟΙΓΟΜΕΝΟ - ΠΡΟΒΑΛΛΟΜΕΝΟ
DOUBLE LEAF CASEMENT / TILT-N-TURN WINDOW

M 15024
M 15018
M 15012

M 15004

M 15024
M 15018
M 15012

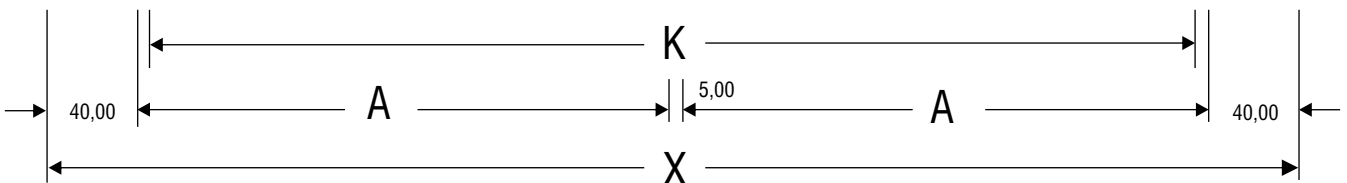
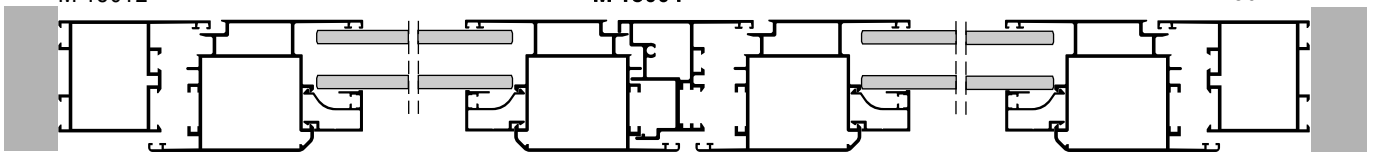

ΠΛΑΤΟΣ ΦΥΛΛΟΥ
(WIDTH OF SASH)

$$A = \frac{X - 85}{2} \text{ mm} \quad \text{ή (or)} \quad A = \frac{K + 7}{2} \text{ mm}$$

ΥΨΟΣ ΦΥΛΛΟΥ
(HEIGHT OF SASH)

$$A = Y - 80 \text{ mm} \quad \text{ή (or)} \quad A = M + 12 \text{ mm}$$

ΠΟΡΤΑ
DOOR

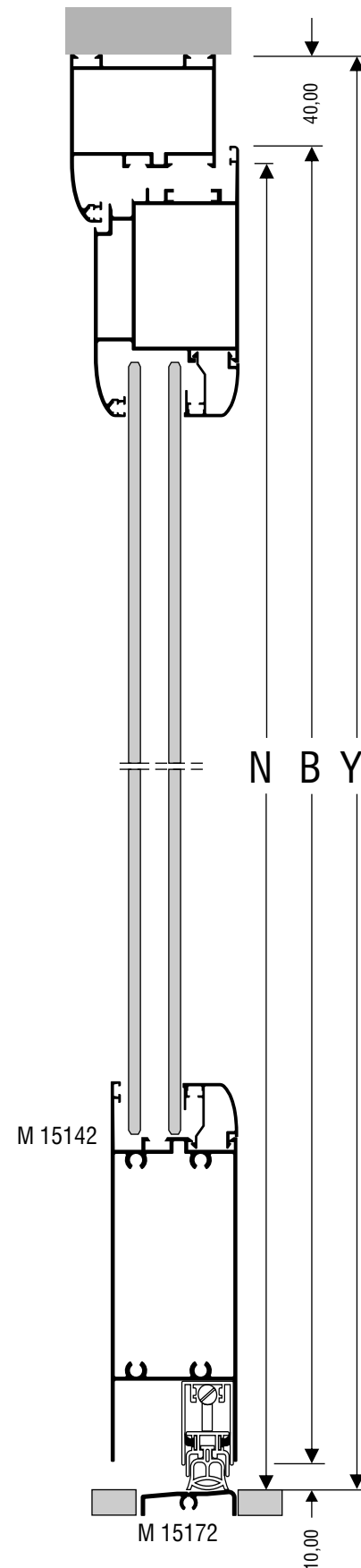
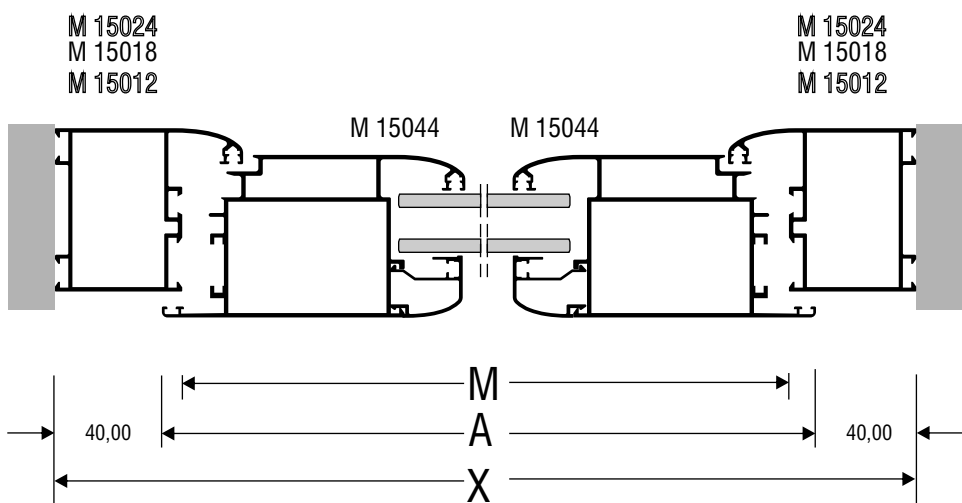

ΠΛΑΤΟΣ ΦΥΛΛΟΥ (WIDTH OF SASH)	ή (or)	$A = X - 80 \text{ mm}$
		$A = M + 12 \text{ mm}$

ΥΨΟΣ ΦΥΛΛΟΥ (HEIGHT OF SASH)	ή (or)	$B = Y - 50 \text{ mm}$
		$B = N - 4 \text{ mm}$

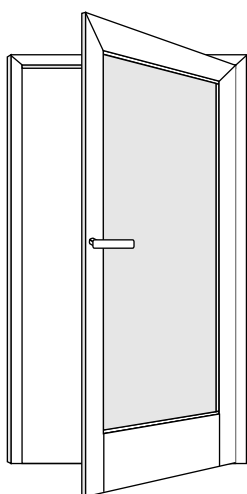

ΠΟΡΤΑ
DOOR

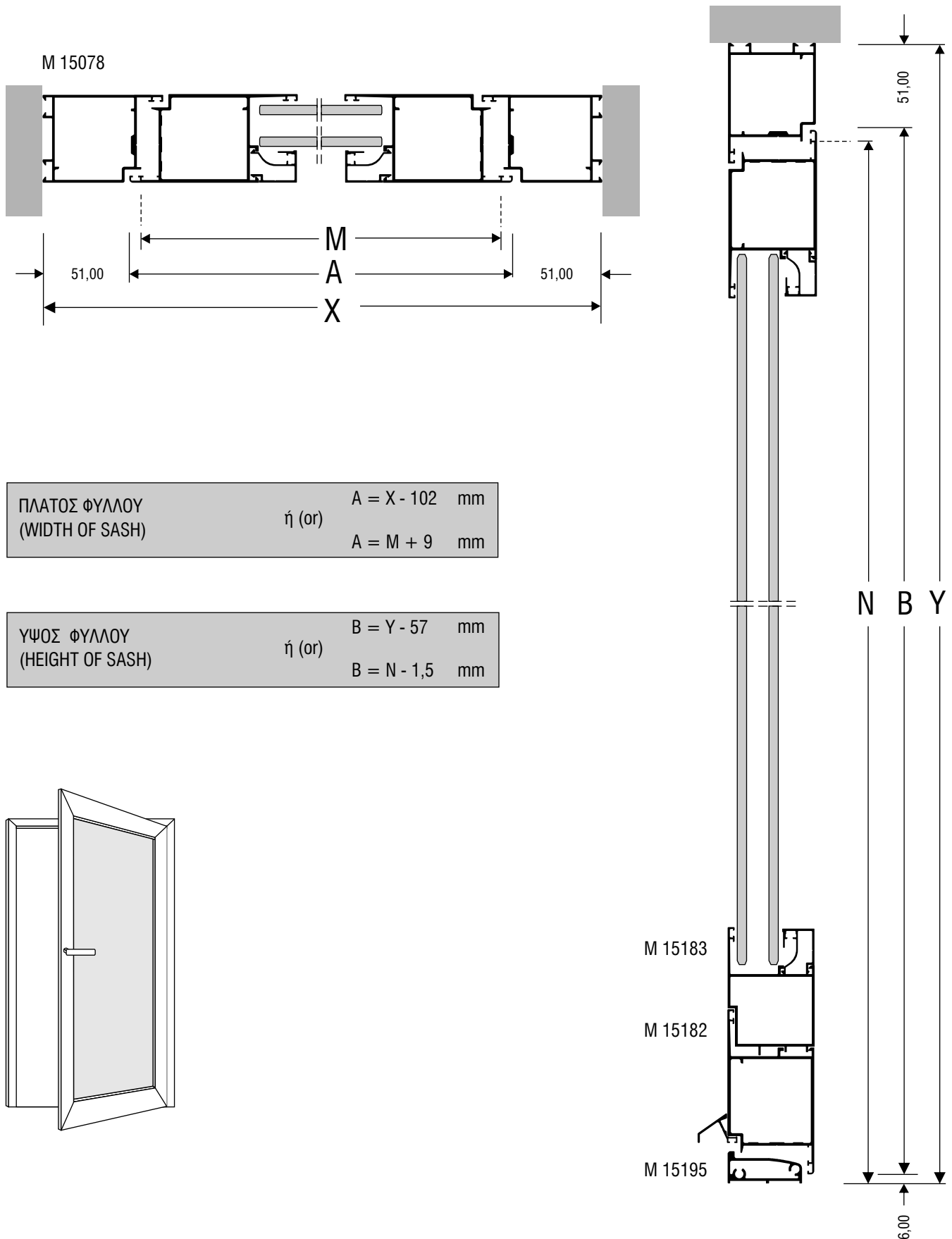

ΠΟΡΤΑ
DOOR

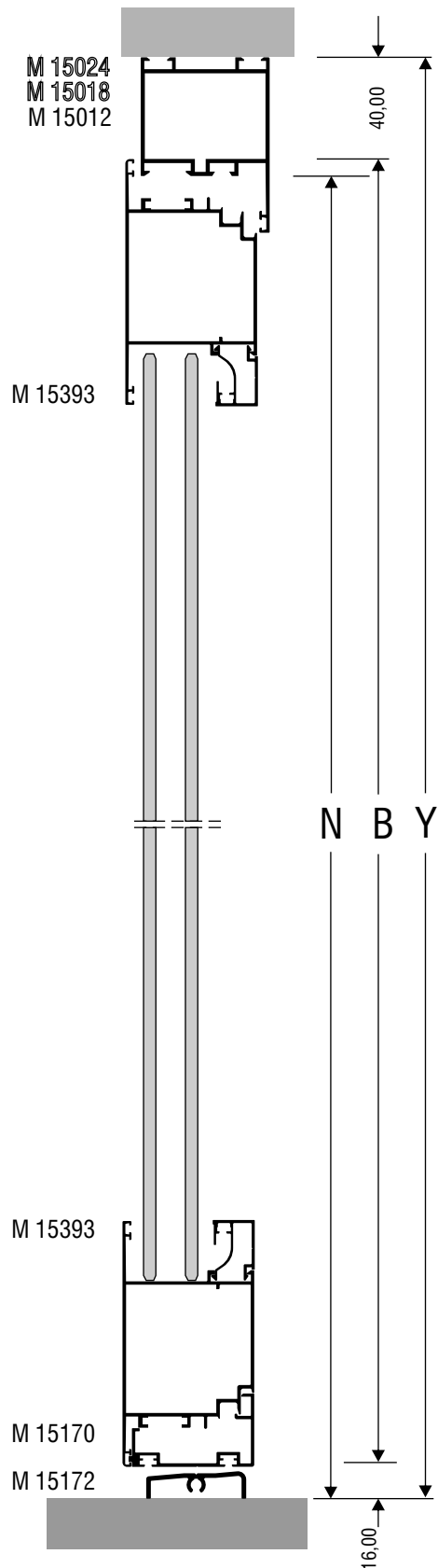
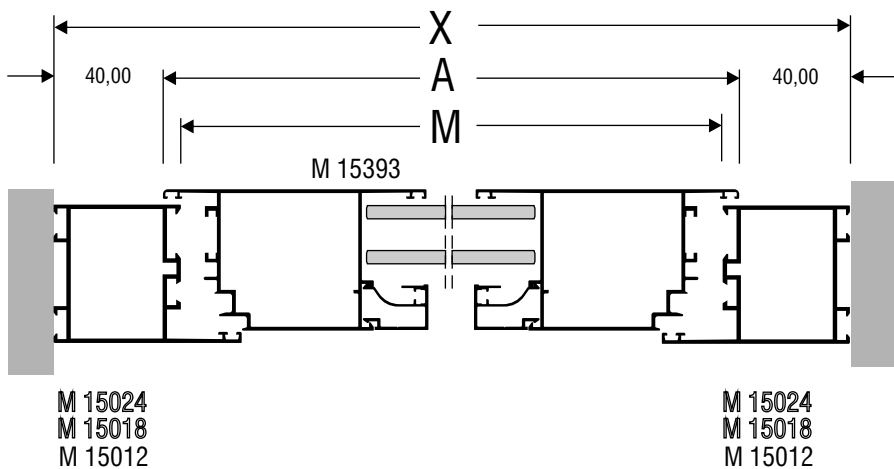

ΠΛΑΤΟΣ ΦΥΛΛΟΥ (WIDTH OF SASH)	ή (or)	$A = X - 80$ mm
		$A = M + 12$ mm

ΥΨΟΣ ΦΥΛΛΟΥ (HEIGHT OF SASH)	ή (or)	$B = Y - 56$ mm
		$B = N - 10$ mm

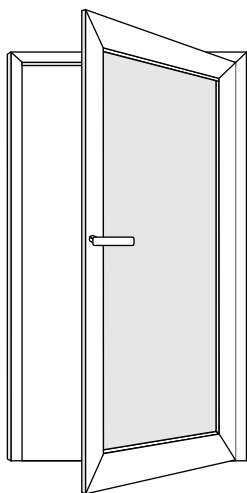

ΠΟΡΤΑ
DOOR

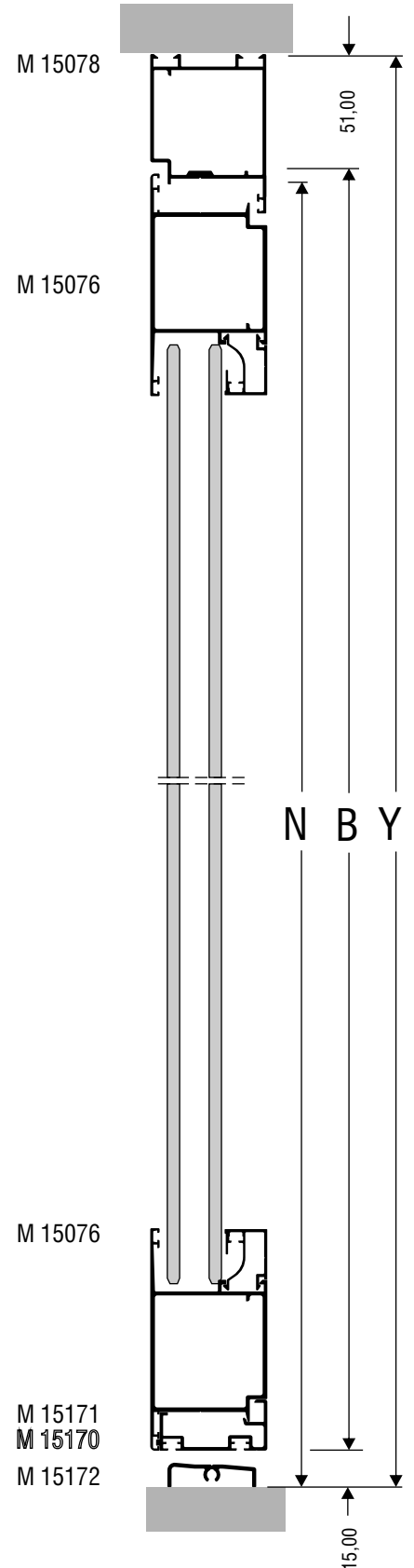
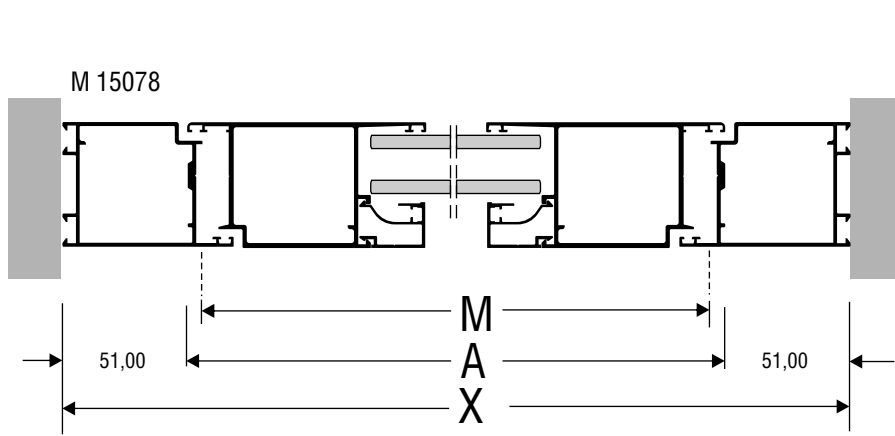

ΠΛΑΤΟΣ ΦΥΛΛΟΥ (WIDTH OF SASH)	ή (or)	$A = X - 102$ mm
		$A = M + 9$ mm

ΥΨΟΣ ΦΥΛΛΟΥ (HEIGHT OF SASH)	ή (or)	$B = Y - 66$ mm
		$B = N - 10,5$ mm

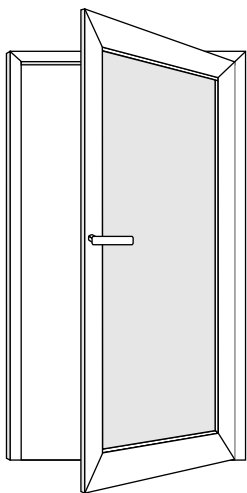

ΠΟΡΤΑ ΔΙΠΛΗ
DOUBLE DOORS

M 15024
M 15012
M 15018

M 15024
M 15012
M 15018

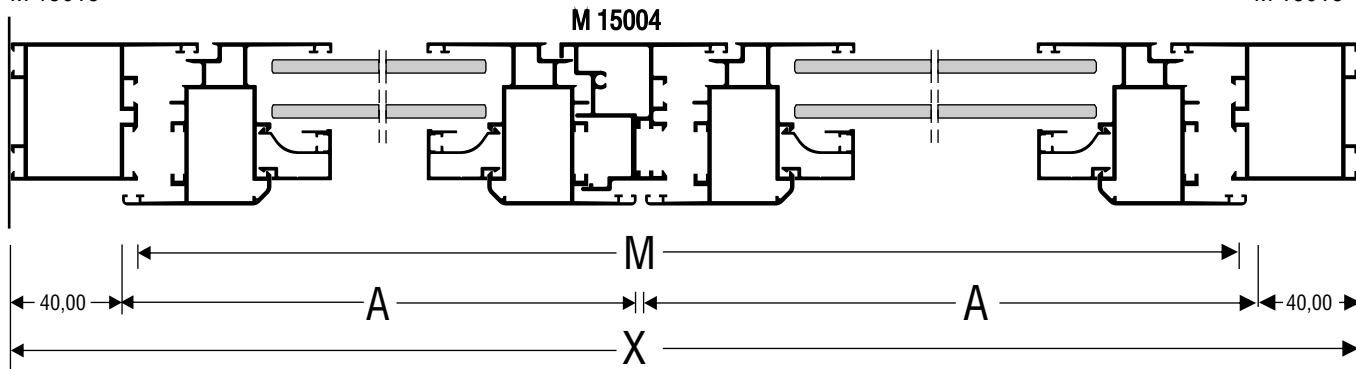

ΠΛΑΤΟΣ ΦΥΛΛΟΥ
(WIDTH OF SASH) $A = \frac{X - 85}{2}$ mm ή (or) $A = \frac{M + 7}{2}$ mm

ΥΨΟΣ ΦΥΛΛΟΥ
(HEIGHT OF SASH) ή (or) $B = Y - 50$ mm
 $B = N - 4$ mm

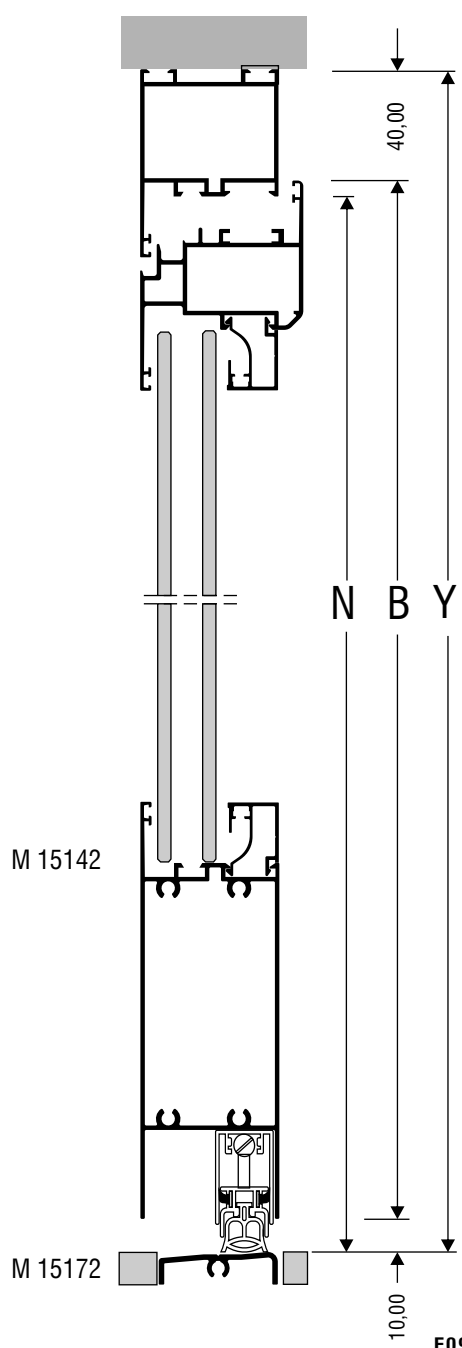
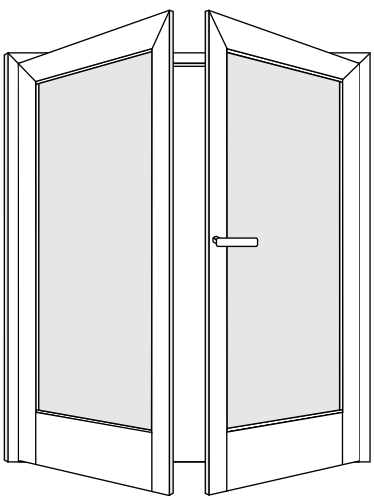

ΠΟΡΤΑ ΔΙΠΛΗ
DOUBLE DOORS

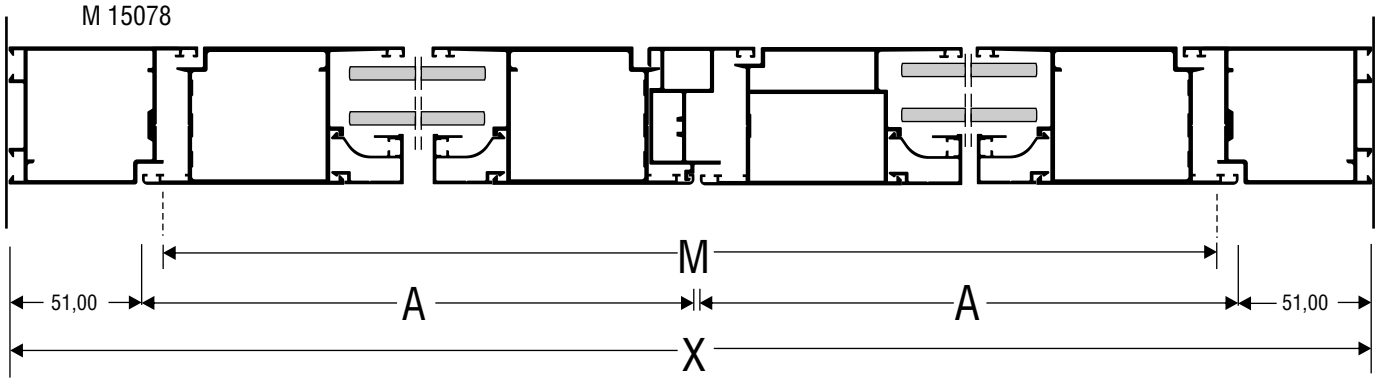

ΠΛΑΤΟΣ ΦΥΛΛΟΥ
(WIDTH OF SASH)

$$A = \frac{X - 107}{2} \text{ mm} \quad \text{ή (or)} \quad A = \frac{M + 4}{2} \text{ mm}$$

ΥΨΟΣ ΦΥΛΛΟΥ
(HEIGHT OF SASH)

$$\text{ή (or)} \quad B = Y - 57 \text{ mm}$$

$$B = N - 1,5 \text{ mm}$$

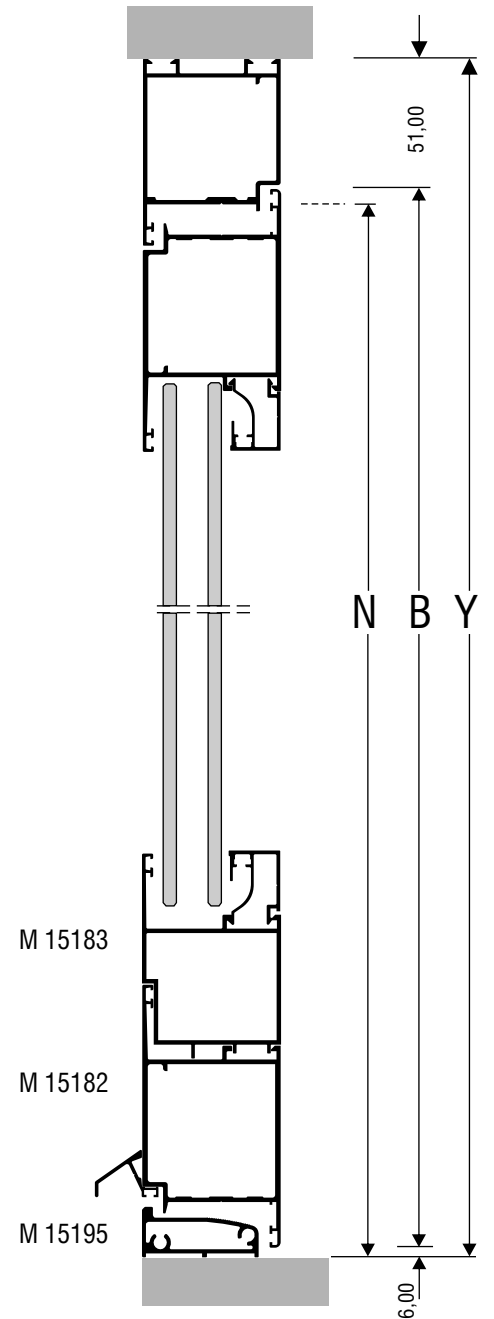
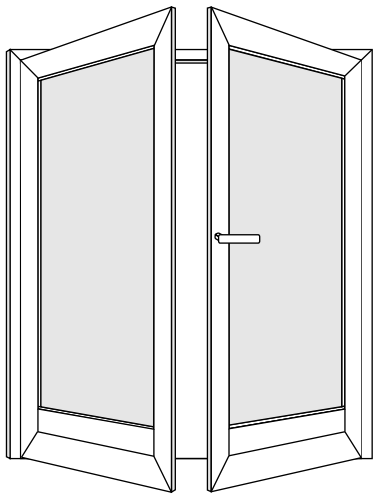

**Λεπτομέρειες
Details**

ΜΟΝΟΦΥΛΛΟ ΑΝΟΙΓΟΜΕΝΟ SINGLE LEAF CASEMENT

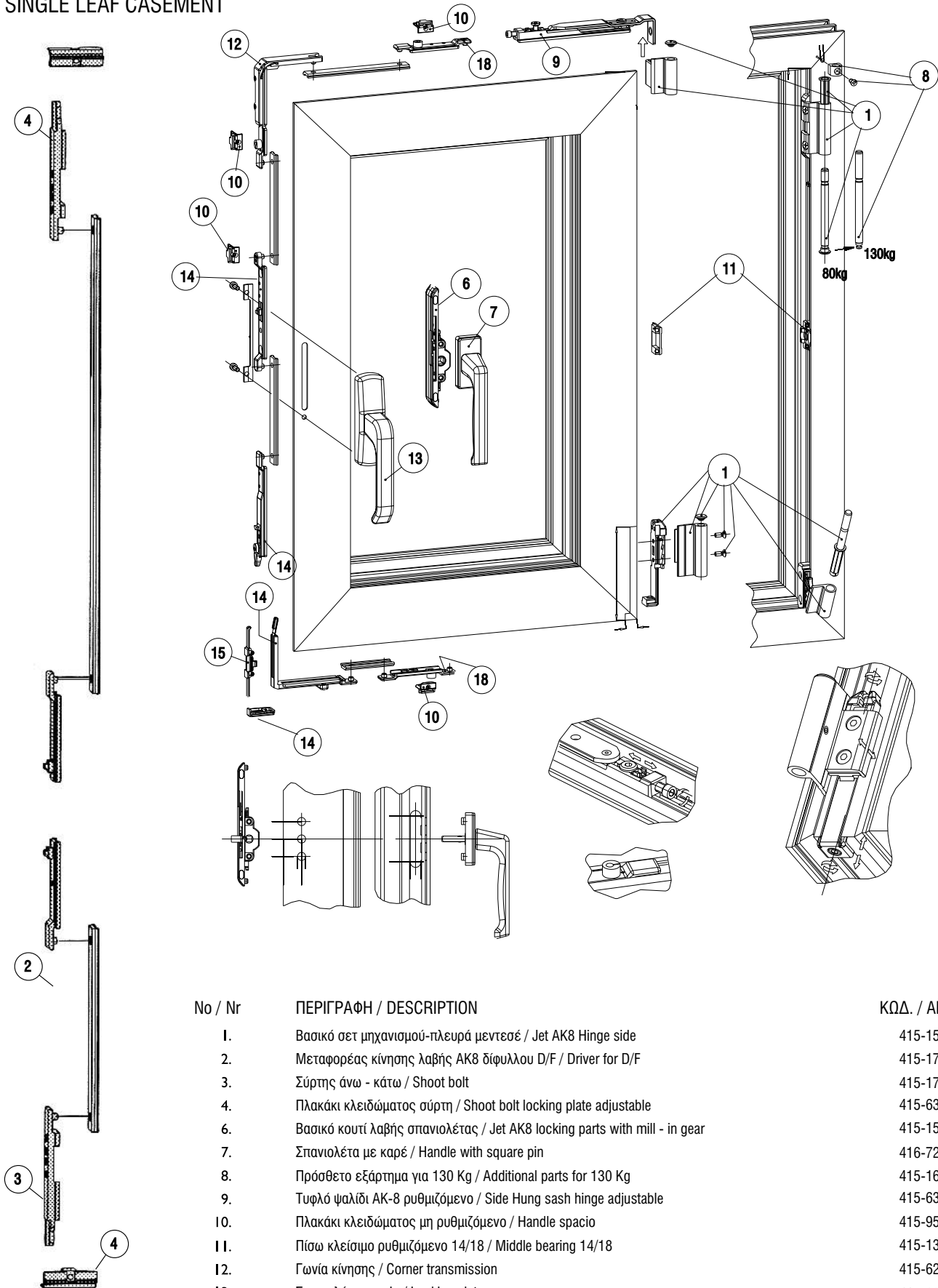

No / Nr	ΠΕΡΙΓΡΑΦΗ / DESCRIPTION	ΚΩΔ. / ART. No
1.	Βασικό σετ μηχανισμού-πλευρά μεντεσέ / Jet AK8 Hinge side	415-15-800-**
2.	Μεταφορέας κίνησης λαβής AK8 δίφυλλου D/F / Driver for D/F	415-17-527-00
3.	Σύρτης άνω - κάτω / Shoot bolt	415-17-509-00
4.	Πλακάκι κλειδώματος σύρτη / Shoot bolt locking plate adjustable	415-63-961-00
6.	Βασικό κουτί λαβής σπανιολέτας / Jet AK8 locking parts with mill - in gear	415-15-811-00
7.	Σπανιολέτα με καρτέ / Handle with square pin	416-72-250-**
8.	Πρόσθετο εξάρτημα για 130 Kg / Additional parts for 130 Kg	415-16-595-00
9.	Τυφλό ψαλίδι AK-8 ρυθμιζόμενο / Side Hung sash hinge adjustable	415-63-106-00
10.	Πλακάκι κλειδώματος μη ρυθμιζόμενο / Handle spacio	415-95-901-00
11.	Πίσω κλείσιμο ρυθμιζόμενο 14/18 / Middle bearing 14/18	415-13-529-00
12.	Γωνία κίνησης / Corner transmission	415-62-290-00
13.	Σπανιολέτα spacio / Locking plate	415-63-172-**
14.	Βασικό σετ μηχανισμού-πλευρά χειρουλιού / Jet AK8 locking parts for geared handle	415-15-801-00
15.	Πλακάκι ανάκλισης / Tilt - locking plate	415-96-401-00
18.	Ενίσχυση ALU / Locking pin element	415-62-390-00

ΜΟΝΟΦΥΛΛΟ ΑΝΟΙΓΟΜΕΝΟ - ΠΡΟΒΑΛΛΟΜΕΝΟ SINGLE LEAF CASEMENT / TILT-N-TURN WINDOW

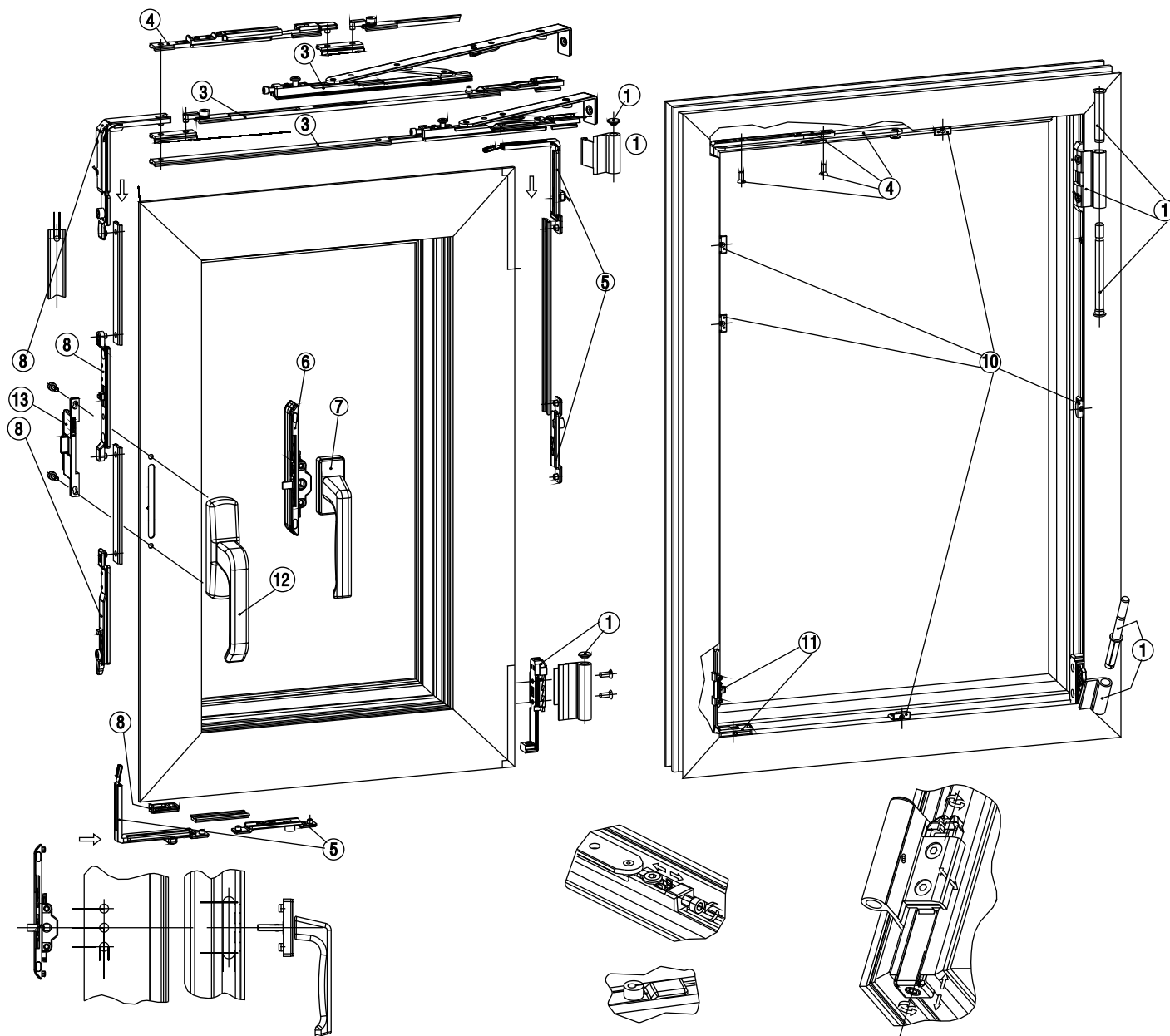

No / Nr	ΠΕΡΙΓΡΑΦΗ / DESCRIPTION	ΚΩΔ. / ART. No
1.	Βασικό σετ μηχανισμού - πλευρά μεντεσέ / Jet AK8 Hinge side	415-15-800-**
3.	Ψαλίδι (ανάλογο με το πλάτος του φύλλου) / Jet AK stay arm	415-15-80*-00
4.	Ψαλίδι δεύτερο AK-IK/ AK-8 / Additional stay arm	415-12-964-00
5.	Βασικό κουτί πίσω ενίσχυσης / Bag of middle lock	415-15-808-00
6.	Βασικό κουτί λαβής σπανιολέτας / Jet AK8 locking parts with mill - in gear	415-15-811-00
7.	Σπανιολέτα με καρτέ / Handle with square pin	416-72-250-**
8.	Βασικό σετ μηχανισμού - πλευρά χερουλιού / Jet AK8 locking parts for geared handle	415-15-801-00
10.	Πλακάκι κλειδώματος μη ρυθμιζόμενο / Locking plate	415-95-901-00
11.	Πλακάκι ανάκλισης / Tilt - locking plate	415-96-401-00
12.	Χειρολαβή spacio / Handle spacio	415-46-551-**
13.	Ασφάλεια χερουλιού / Wrong operation safety device	415-63-654-00

ΣΥΡΤΕΣ

No / Nr	ΠΕΡΙΓΡΑΦΗ / DESCRIPTION	ΚΩΔ. / ART. No
21.	Πλακάκι κλειδαριάς σύρτη εξωτερικό D/F Bolt locking plate D/F	415-15-819-00
22.	Σύρτης εξωτερικός D/F Shoot bolt D/F	415-15-817-00
23.	Χειριστήριο εξωτερικών συρτών D/K Slide for shoot bolt D/K	415-15-816-00
45.	Μονοκόμματος σύρτης εξωτερικός Rebate shoot bolt	415-15-803-00
43.	Πλακάκι κλειδώματος σύρτη ρυθμιζόμενο Locking plate	415-63-961-00
47.	Ντίτζα σύνδεσης μονοκομ. σύρτη εξωτερική Push rod for rebate shoot bolt	415-94-160-00
50.	Κάλυμα λαβής μονοκόμματος σύρτη Protective cap for rebate lever	416-80-009-00
35.	Βασικό κουτί μονοκόμματος σύρτη Bag of inactive sash gear	415-45-929-00

ΟΔΗΓΙΕΣ ΕΠΙΛΟΓΗΣ ΕΞΑΡΤΗΜΑΤΩΝ ΜΗΧΑΝΙΣΜΟΥ ΑΚ8

CALCULATION OF THE MECHANISM AK8

- **Βασικό σετ μηχανισμού - πλευρά μεντεσέ / Basic bag Jet AK8 Hinge side (415-15-800-**)**
Για κάθε φύλλο πρέπει να επιλέξουμε 1 σετ μεντεσέ, δηλ. για ένα δίφυλλο πρέπει να επιλέξουμε 2 σετ. Εδώ θα πρέπει να προσέξουμε τα kgr του φύλλου διότι το συγκεκριμένο σετ μεντεσέ είναι για 80 kgr, εάν όμως θέλουμε να ξεπεράσουμε τα συγκεκριμένα kgr τότε έχουμε τη δυνατότητα να επιλέξουμε επιπλέον το πρόσθετο εξάρτημα για 130 kgr 415-16-595-00.

For each sash you have to choose one (1) set of hinge, for example for a double sash you have to choose two (2) sets of hinge. Nevertheless, you have to pay attention to the weight of the sash, because this kind of hinge is appropriate only if the weight of each sash does not exceed 80 kg. If the sash exceeds this weight, it is necessary to choose an additional accessory suitable for a sash of 130 kg 415-16-595-00.

- **Βασικό σετ μηχανισμού - πλευρά χερουλιού / Jet AK8 Locking parts for geared handle (415-15-801-00)**
Για κάθε φύλλο που θέλουμε να έχει λαβή (ανοιγόμενο ή ανοιγο - ανακλινόμενο) θα πρέπει να πάρουμε 1 σετ από το βασικό σετ μηχανισμού.

For each sash having a geared handle (either opening or tilt 'n turn) one (1) set from the basic bag mechanism should be taken.

- **Ψαλίδι (ανάλογο με το πλάτος του φύλλου) / Jet AK stay arm (according the width of sash) (415-15-80*-00)**
Για κάθε φύλλο ανοιγο - ανακλινόμενο θα πρέπει να επιλέξουμε το ανάλογο ψαλίδι σύμφωνα με τη διάσταση της πατούρας του φύλλου.

For each tilt'n turn sash, a suitable stay arm has to be chosen according the dimensions of the fittings of the sash.

- **Τυφλό ψαλίδι ΑΚ-8 ρυθμιζόμενο / Side Hung sash hinge adjustable (415-63-106-00)**
Για κάθε φύλλο ανοιγόμενο θα πρέπει να επιλέξουμε το τυφλό ψαλίδι
δηλ. μονόφυλλο ανοιγόμενο =1 / δίφυλλο ανοιγο-ανακλινόμενο =1.

For each opening sash, one (1) side hung sash hinge adjustable should be chosen
i.e. one (1) for single opening sash, one (1) for tilt 'n turn double sash.

- **Λαβή / Handle**
Σύμφωνα με την αισθητική μας επιλέγουμε και την ανάλογη σπανιολέτα.

The suitable geared handle has to be chosen according to the esthetics of the client.

- **Βασικό κουτί πίσω ενίσχυσης / Bag of middle lock (415-15-808-00)**
Στα φύλλα τα ανοιγο - ανακλινόμενα θα πρέπει να επιλέγουμε 1 σετ από το βασικό κουτί πίσω ενίσχυσης.
Εδώ θα πρέπει να προσέξουμε ότι ανάλογα με το ύψος του φύλλου επιλέγουμε και την απαιτούμενη ποσότητα που χρειαζόμαστε. Επίσης μπορούμε να χρησιμοποιήσουμε το σετ και για ενίσχυση, στο πλάτος του φύλλου (κάτω μέρος) για καλύτερη ασφάλεια - στεγάνωση της κατασκευής.

In case of tilt'n turn sashes, one (1) bag of middle lock should be chosen. It is important to mention that the necessary quantity is chosen according the height of the sash. Apart from that, this set can be used in order to reinforce the width of the sash for better security and water - air tightness of the construction.

- **Πίσω κλείσιμο ρυθμιζόμενο 14/18 / Middle bearing 14/18 (415-13-529-00)**
Στα φύλλα, τα ανοιγόμενα, θα πρέπει να επιλέγουμε 1 σετ από το πίσω κλείσιμο, που ανάλογα με το ύψος του φύλλου υπολογίζουμε την ποσότητα. π.χ. 1000 mm 1τεμ. - 2000 mm 1τεμ.

In case of opening sashes one (1) of middle bearing is needed. Its quantity depends of the height of the sash.
e.g. 1000 mm 1 piece - 2000 mm 1 piece

- Πλακάκι ανάκλισης / Tilt locking plate (415-96-401-00)

Πάντα 1 τεμάχιο δηλ. μονόφυλλο 1 τεμ. / δίφυλλο 1 τεμ.

Always, one piece has to be used: one piece for a single sash, one piece for double sash

- Πλακάκι κλειδώματος μη ρυθμιζόμενο / Locking plate (415-95-901-00)

Αναλόγως τα κλεισίματα του μηχανισμού που έχουμε εφαρμόσει στη κατασκευή μας.

A locking plate should be chosen according the closings of the mechanism applied to the construction.

ΤΕΧΝΙΚΕΣ ΟΔΗΓΙΕΣ ΜΗΧΑΝΙΣΜΟΥ ΑΛΟΥΜΙΝΙΟΥ

TECHNICAL GUIDELINES OF ALUMINIUM MECHANISM

ΟΡΙΑ ΜΗΧΑΝΙΣΜΟΥ / MECHANISM LIMITS

- Μέγιστο βάρος φύλλου 80 kg. / Maximum weight of sash 80 kg.
- Πλάτος φύλλου από 355 mm έως 1700 mm. / Width of sash from 355 mm to 1700 mm.
- Ύψος φύλλου από 500 mm έως 2400 mm. / Height of sash from 500 mm to 2400 mm.

ΔΙΑΣΤΑΣΕΙΣ ΨΑΛΙΔΙΩΝ / STAY ARM DIMENSIONS

1. Για πλάτος φύλλου 355 mm - 600 mm \Rightarrow ψαλίδι No. 1 (gr. 30)
For width of sash 355 mm - 600 mm \Rightarrow stay arm No. 1 (gr. 30)
2. Για πλάτος φύλλου 601 mm - 1000 mm \Rightarrow ψαλίδι No. 2 (gr. 50)
For width of sash 601 mm - 1000 mm \Rightarrow stay arm No. 2 (gr. 50)
3. Για πλάτος φύλλου 1001 mm - 1300 mm \Rightarrow ψαλίδι No. 3 (gr. 90)
For width of sash 1001 mm - 1300 mm \Rightarrow stay arm No. 3 (gr. 90)
4. Για πλάτος φύλλου 1300 mm - 1700 mm \Rightarrow χρησιμοποιούμε ψαλίδι No. 2 + δεύτερο ψαλίδι
For width of sash 1300 mm - 1700 mm \Rightarrow we use stay arm No. 2 + a second stay arm

ΚΟΠΕΣ ΝΤΙΖΩΝ ΣΥΝΔΕΣΗΣ (Ανοιγόμενου - Ανακλινόμενου φύλλου)

CUT ANALYSIS OF ROD CONNECTORS (TILT' N TURN SASH)

1. Ντίζα T1 (ή κάτω από λαβή)

$T1 = K.A. - 210 \text{ mm}$

Όπου K.A. = Απόσταση κέντρου λαβής από κάτω μέρος φύλλου

Rod T1 (or under the geared handle)

$T1 = C.G. - 210 \text{ mm}$

Where C.G. = Distance between the center and the geared handle from the down side of the sash

2. Ντίζα T2 (ή πάνω από λαβή)

$T2 = Y.\Phi. - K.A. - 210 \text{ mm}$

Όπου Y.Φ. = Ολικό ύψος φύλλου

Rod T2 (or above the geared handle)

$T2 = H.S. C.G. - 210 \text{ mm}$

Where H.S. = Total height of sash

3. Ντίζα T3 (ή στο ψαλίδι)

Για ψαλίδι No. 1 \Rightarrow T3 = Π.Φ. - 95 mm (ενσωματωμένη ντίζα)

Για ψαλίδι No. 2 \Rightarrow T3 = Π.Φ. - 535 mm

Όπου Π.Φ. = Ολικό πλάτος φύλλου

Για ψαλίδι No. 3 (gr. 90) \Rightarrow T3 = Π.Φ. - 785 mm

Rod T3 (ή στο stay arm)

For stay arm No. 1 \Rightarrow T3 = Π.Φ. - 95 mm (incorporated rod)

For stay arm No. 2 \Rightarrow T3 = Π.Φ. - 535 mm

Where W.S. = Total width of sash

For stay arm No. 3 (gr. 90) \Rightarrow T3 = W.S. - 785 mm

ΚΟΠΕΣ ΝΤΙΖΩΝ ΣΥΝΔΕΣΗΣ (Αριστερού ανοιγόμενου φύλλου - μηχανισμός ALLEN) CUT ANALYSIS OF ROD CONNECTORS (left hinged casement ALLEN mechanism)

1. Ντίζα T8 (ή κάτω από μηχανισμό ALLEN)

T8 = Θ.Α. - 132 mm

Rod T8 (or under the ALLEN mechanism)

T8 = A.P. - 132 mm

2. Ντίζα T9 (ή πάνω από μηχανισμό ALLEN)

T9 = Θ.Α. - Κ.Λ. - 130,50 mm

Όπου Θ.Α. = Θέση ALLEN

Rod T9 (or above the ALLEN mechanism)

T9 = A.P. - C.G. - 130,50 mm

Where A.P. = ALLEN Position

ΣΥΝΑΡΜΟΛΟΓΗΣΗ ΜΗΧΑΝΙΣΜΟΥ ΣΤΗΝ ΚΑΣΑ MOUNTING THE MECHANISM TO THE FRAME

1. Τοποθέτηση και σύσφιξη του γωνιακού μεντεσέ (κάτω).
 2. Προσαρμογή του πείρου και τοποθέτηση στον κυρίως μεντεσέ.
 3. Τοποθέτηση και σύσφιξη του μεντεσέ του ψαλιδιού (πάνω).
 4. Σε περίπτωση χρήσης πρόσθετου ψαλιδιού:
Τρυπήστε τις οπές συγκράτησης στο κανάλι της κάσας.
Βιδώστε το πρόσθετο ψαλίδι.
 5. Τοποθετήστε τα πλακάκια κλεισίματος σύμφωνα με το σχέδιο.
Το πλακάκι ανάκλισης πρέπει να φωλιάζει.
 6. Τελική συναρμολόγηση.
Κρεμάστε το φύλλο στον κάτω μεντεσέ.
Πιέστε τον πάνω πείρο προς τα πάνω, μέχρι να τερματίσει.
Σφίξτε τους μεντεσέδες και τοποθετήστε την τάπα.
1. Setting & tightening of corner hinge (down).
 2. Adaptation of the axle for stay arm bearing and its setting to the basic hinge.
 3. Setting & tightening of the stay arm hinge (up).
 4. In case of additional stay arm use:
Drill the holding holes to the channel of the frame.
Screw the additional stay arm.
 5. Set the locking plate of closing according to the drawing.
The tilt-locking plate has to rest.
 6. Final assembly.
Mount the sash to the down hinge.
Press the upper pin connector towards up until it rests.
Tighten the hinges and set the holding end.

ΣΥΝΑΡΜΟΛΟΓΗΣΗ ΜΗΧΑΝΙΣΜΟΥ ΣΤΟ ΦΥΛΛΟ MOUNTING THE MECHANISM TO THE SASH

1. Τοποθετήστε τη γωνία μεταφοράς κίνησης.
 2. Τοποθετήστε τον πάνω μεντεσέ στο ψαλίδι και ασφαλίστε τον, με περιστροφή της ασφάλειας του ψαλιδιού.
 3. Περάστε το ψαλίδι στο κανάλι του φύλλου.
 4. Προσαρμόστε τον μεντεσέ ψαλιδιού στο φτερό του φύλλου.
 5. Προσαρμόστε το ψαλίδι και βιδώστε το, μέχρι να τερματίσει η βίδα.
 6. Περάστε το κλείστρο και βιδώστε την γωνία μεταφοράς κίνησης.
 7. Τοποθετήστε το χερούλι με την ασφάλεια.
 8. Περάστε την γωνία του κάτω μεντεσέ και βιδώστε τον μεντεσέ.
1. Put the corner transmission.
 2. Put the upper hinge to the stay arm and secure it by twisting the security pin of the stay arm.
 3. Pass the stay arm to the rod channel of the sash.
 4. Adapt the hinge of the stay arm over the end of the sash.
 5. Adapt stay arm and screw it until it ends.
 6. Pass the latch and screw the corner transmission.
 7. Put the handle with the security pin.
 8. Pass the lower corner piece of the hinge and screw the hinge.

**Εξαρτήματα
Accessories**



ΚΩΔΙΚΟΣ : ART. No :	110-11-***-**	STOCK No :
ΠΕΡΙΓΡΑΦΗ: DESCRIPTION:	ΓΩΝΙΑ ΣΥΝΔΕΣΗΣ ΠΡΕΣΑΡΙΣΤΗ PRESS CORNER	
ΥΛΙΚΟ: MATERIAL:	ΑΛΟΥΜΙΝΙΟ ALUMINIUM	ΣΥΣΚΕΥΑΣΙΑ: PACKAGE:
ΚΩΔΙΚΟΙ: ART No:	110-11-384-00	ΧΡΩΜΑ: COLOR:
		ΑΒΑΦΟ

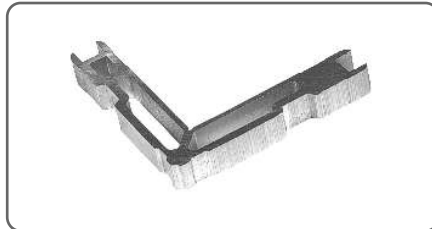

ΚΩΔΙΚΟΣ : ART. No :	110-13-***-**	STOCK No :
ΠΕΡΙΓΡΑΦΗ: DESCRIPTION:	ΓΩΝΙΑ ΣΥΝΔΕΣΗΣ ΠΡΕΣΑΡΙΣΤΗ PRESS CORNER	
ΥΛΙΚΟ: MATERIAL:	ΑΛΟΥΜΙΝΙΟ ALUMINIUM	ΣΥΣΚΕΥΑΣΙΑ: PACKAGE:
ΚΩΔΙΚΟΙ: ART No:	110-13-074-00, 110-13-400-00, 110-13-464-00, 110-13-554-00	ΧΡΩΜΑ: COLOR:
		ΑΒΑΦΟ MILL FINISH

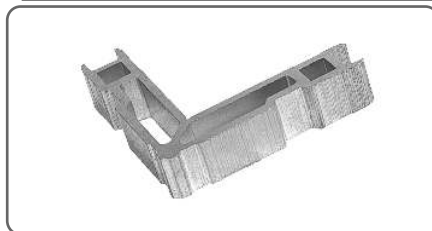

ΚΩΔΙΚΟΣ : ART. No :	110-15-***-**	STOCK No :
ΠΕΡΙΓΡΑΦΗ: DESCRIPTION:	ΓΩΝΙΑ ΣΥΝΔΕΣΗΣ ΠΡΕΣΑΡΙΣΤΗ PRESS CORNER	
ΥΛΙΚΟ: MATERIAL:	ΑΛΟΥΜΙΝΙΟ ALUMINIUM	ΣΥΣΚΕΥΑΣΙΑ: PACKAGE:
ΚΩΔΙΚΟΙ: ART No:	110-15-076-00, 110-15-400-00	ΧΡΩΜΑ: COLOR:
		ΑΒΑΦΟ MILL FINISH

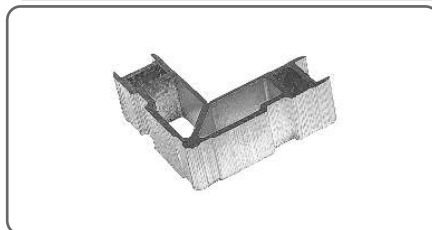

ΚΩΔΙΚΟΣ : ART. No :	110-23-***-**	STOCK No :
ΠΕΡΙΓΡΑΦΗ: DESCRIPTION:	ΓΩΝΙΑ ΣΥΝΔΕΣΗΣ ΠΡΕΣΑΡΙΣΤΗ PRESS CORNER	
ΥΛΙΚΟ: MATERIAL:	ΑΛΟΥΜΙΝΙΟ ALUMINIUM	ΣΥΣΚΕΥΑΣΙΑ: PACKAGE:
ΚΩΔΙΚΟΙ: ART No:	110-23-270-00, 110-23-400-00, 110-23-416-00,	ΧΡΩΜΑ: COLOR:
		ΑΒΑΦΟ MILL FINISH

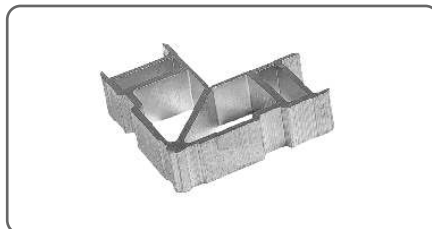

ΚΩΔΙΚΟΣ : ART. No :	110-33-***-**	STOCK No :
ΠΕΡΙΓΡΑΦΗ: DESCRIPTION:	ΓΩΝΙΑ ΣΥΝΔΕΣΗΣ ΠΡΕΣΑΡΙΣΤΗ PRESS CORNER	
ΥΛΙΚΟ: MATERIAL:	ΑΛΟΥΜΙΝΙΟ ALUMINIUM	ΣΥΣΚΕΥΑΣΙΑ: PACKAGE:
ΚΩΔΙΚΟΙ: ART No:	110-33-074-00, 110-33-464-00, 110-33-554-00	ΧΡΩΜΑ: COLOR:
		ΑΒΑΦΟ

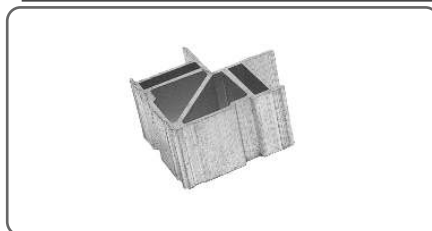



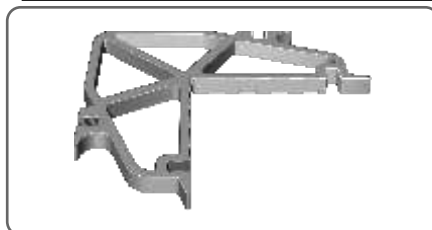

ΚΩΔΙΚΟΣ : ART. No :	110-43-***-**	STOCK No :
ΠΕΡΙΓΡΑΦΗ: DESCRIPTION:	ΓΩΝΙΑ ΣΥΝΔΕΣΗΣ ΠΡΕΣΑΡΙΣΤΗ PRESS CORNER	
ΥΛΙΚΟ: MATERIAL:	ΑΛΟΥΜΙΝΙΟ ALUMINIUM	ΣΥΣΚΕΥΑΣΙΑ: PACKAGE:
ΚΩΔΙΚΟΙ: ART No:	110-43-389-00, 110-33-400-00	ΧΡΩΜΑ: COLOR:
		ΑΒΑΦΟ MILL FINISH

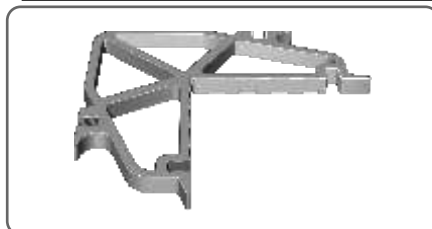

ΚΩΔΙΚΟΣ : ART. No :	111-11-***-**	STOCK No :
ΠΕΡΙΓΡΑΦΗ: DESCRIPTION:	ΓΩΝΙΑ ΣΥΝΔΕΣΗΣ ΚΑΡΦΩΤΗ NAIL CORNER	
ΥΛΙΚΟ: MATERIAL:	ΑΛΟΥΜΙΝΙΟ ALUMINIUM	ΣΥΣΚΕΥΑΣΙΑ: PACKAGE:
ΚΩΔΙΚΟΙ: ART No:	111-11-384-00	ΧΡΩΜΑ: COLOR:
		ΑΒΑΦΟ MILL FINISH

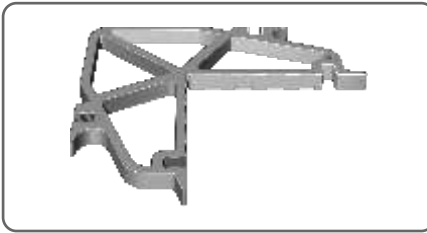
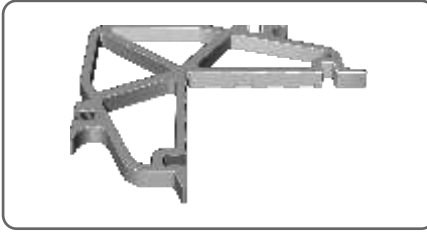
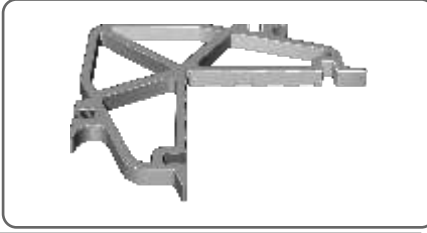
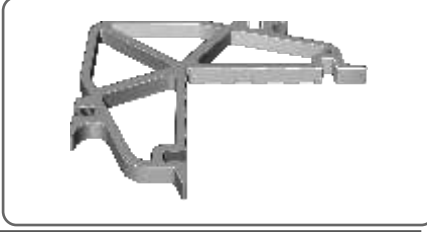
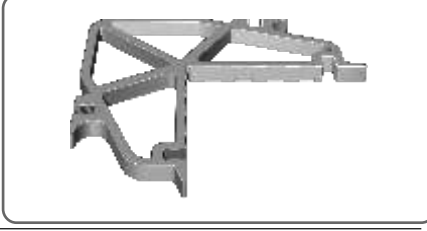

ΚΩΔΙΚΟΣ : ART. No :	111-13-***-**	STOCK No :
ΠΕΡΙΓΡΑΦΗ: DESCRIPTION:	ΓΩΝΙΑ ΣΥΝΔΕΣΗΣ ΚΑΡΦΩΤΗ NAIL CORNER	
ΥΛΙΚΟ: MATERIAL:	ΑΛΟΥΜΙΝΙΟ ALUMINIUM	ΣΥΣΚΕΥΑΣΙΑ: PACKAGE:
ΚΩΔΙΚΟΙ: ART No:	111-13-074-00, 111-13-400-00, 111-13-464-00, 111-13-554-00	ΧΡΩΜΑ: COLOR:
		ΑΒΑΦΟ MILL FINISH

STOCK No :		ΚΩΔΙΚΟΣ : ART. No :	111-15-***_**	
ΠΕΡΙΓΡΑΦΗ: DESCRIPTION:	ΓΩΝΙΑ ΣΥΝΔΕΣΗΣ ΚΑΡΦΩΤΗ NAIL CORNER			
ΥΛΙΚΟ: MATERIAL:	ΑΛΟΥΜΙΝΙΟ ALUMINIUM	ΣΥΣΚΕΥΑΣΙΑ: PACKAGE:		
ΚΩΔΙΚΟΙ: ART No:	111-15-076-00, 111-15-400-00	ΧΡΩΜΑ: COLOR:	ΑΒΑΦΟ MILL FINISH	
STOCK No :		ΚΩΔΙΚΟΣ : ART. No :	111-23-***_**	
ΠΕΡΙΓΡΑΦΗ: DESCRIPTION:	ΓΩΝΙΑ ΣΥΝΔΕΣΗΣ ΚΑΡΦΩΤΗ NAIL CORNER			
ΥΛΙΚΟ: MATERIAL:	ΑΛΟΥΜΙΝΙΟ ALUMINIUM	ΣΥΣΚΕΥΑΣΙΑ: PACKAGE:		
ΚΩΔΙΚΟΙ: ART No:	111-23-270-00, 111-23-400-00, 111-23-464-00, 111-23-554-00	ΧΡΩΜΑ: COLOR:	ΑΒΑΦΟ MILL FINISH	
STOCK No :		ΚΩΔΙΚΟΣ : ART. No :	111-33-***_**	
ΠΕΡΙΓΡΑΦΗ: DESCRIPTION:	ΓΩΝΙΑ ΣΥΝΔΕΣΗΣ ΚΑΡΦΩΤΗ NAIL CORNER			
ΥΛΙΚΟ: MATERIAL:	ΑΛΟΥΜΙΝΙΟ ALUMINIUM	ΣΥΣΚΕΥΑΣΙΑ: PACKAGE:		
ΚΩΔΙΚΟΙ: ART No:	111-33-076-00, 111-33-464-00, 111-33-554-00	ΧΡΩΜΑ: COLOR:	ΑΒΑΦΟ MILL FINISH	
STOCK No :		ΚΩΔΙΚΟΣ : ART. No :	111-43-***_**	
ΠΕΡΙΓΡΑΦΗ: DESCRIPTION:	ΓΩΝΙΑ ΣΥΝΔΕΣΗΣ ΚΑΡΦΩΤΗ NAIL CORNER			
ΥΛΙΚΟ: MATERIAL:	ΑΛΟΥΜΙΝΙΟ ALUMINIUM	ΣΥΣΚΕΥΑΣΙΑ: PACKAGE:		
ΚΩΔΙΚΟΙ: ART No:	111-43-389-00, 111-43-400-00	ΧΡΩΜΑ: COLOR:	ΑΒΑΦΟ MILL FINISH	
STOCK No :		ΚΩΔΙΚΟΣ : ART. No :	111-57-***_**	
ΠΕΡΙΓΡΑΦΗ: DESCRIPTION:	ΓΩΝΙΑ ΣΥΝΔΕΣΗΣ ΚΑΡΦΩΤΗ NAIL CORNER			
ΥΛΙΚΟ: MATERIAL:	ΑΛΟΥΜΙΝΙΟ ALUMINIUM	ΣΥΣΚΕΥΑΣΙΑ: PACKAGE:		
ΚΩΔΙΚΟΙ: ART No:	111-57-383-00, 111-57-400-00, 111-57-460-00	ΧΡΩΜΑ: COLOR:	ΑΒΑΦΟ MILL FINISH	
STOCK No :		ΚΩΔΙΚΟΣ : ART. No :	112-23-***_**	
ΠΕΡΙΓΡΑΦΗ: DESCRIPTION:	ΓΩΝΙΑ ΣΥΝΔΕΣΗΣ ΜΕ ΡΕΙΖ CORNER FOR SCREWED-ON MECHANISMS			
ΥΛΙΚΟ: MATERIAL:	ΑΛΟΥΜΙΝΙΟ ALUMINIUM	ΣΥΣΚΕΥΑΣΙΑ: PACKAGE:		
ΚΩΔΙΚΟΙ: ART No:	112-23-464-00, 112-23-554-00	ΧΡΩΜΑ: COLOR:	ΑΒΑΦΟ MILL FINISH	
STOCK No :		ΚΩΔΙΚΟΣ : ART. No :	112-33-***_**	
ΠΕΡΙΓΡΑΦΗ: DESCRIPTION:	ΓΩΝΙΑ ΣΥΝΔΕΣΗΣ ΜΕ ΡΕΙΖ CORNER FOR SCREWED-ON MECHANISMS			
ΥΛΙΚΟ: MATERIAL:	ΑΛΟΥΜΙΝΙΟ ALUMINIUM	ΣΥΣΚΕΥΑΣΙΑ: PACKAGE:		
ΚΩΔΙΚΟΙ: ART No:	112-33-464-00, 112-33-554-00	ΧΡΩΜΑ: COLOR:	ΑΒΑΦΟ MILL FINISH	
STOCK No :		ΚΩΔΙΚΟΣ : ART. No :	115-11-***_**	
ΠΕΡΙΓΡΑΦΗ: DESCRIPTION:	ΓΩΝΙΑ ΣΥΝΔΕΣΗΣ ΠΡΕΣΑΡΙΣΤΗ PRESS CORNER			
ΥΛΙΚΟ: MATERIAL:	ΑΛΟΥΜΙΝΙΟ ALUMINIUM	ΣΥΣΚΕΥΑΣΙΑ: PACKAGE:		
ΚΩΔΙΚΟΙ: ART No:	115-11-384-00	ΧΡΩΜΑ: COLOR:	ΑΒΑΦΟ MILL FINISH	

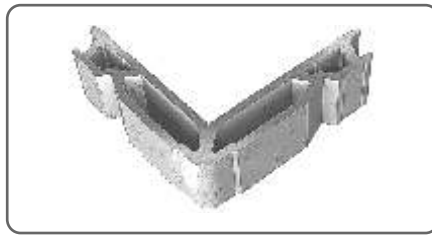

ΚΩΔΙΚΟΣ : ART. No :	115-13-***_**	STOCK No :
ΠΕΡΙΓΡΑΦΗ: DESCRIPTION:	ΓΩΝΙΑ ΣΥΝΔΕΣΗΣ ΠΡΕΣΑΡΙΣΤΗ PRESS CORNER	
ΥΛΙΚΟ: MATERIAL:	ΑΛΟΥΜΙΝΙΟ ALUMINIUM	ΣΥΣΚΕΥΑΣΙΑ: PACKAGE:
ΚΩΔΙΚΟΙ: ART No:	115-13-074-00, 115-13-400-00, 115-13-464-00, 115-13-554-00	ΧΡΩΜΑ: COLOR:
		ΑΒΑΦΟ

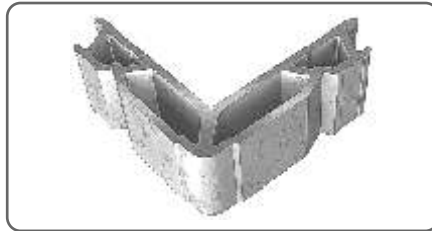

ΚΩΔΙΚΟΣ : ART. No :	115-15-***_**	STOCK No :
ΠΕΡΙΓΡΑΦΗ: DESCRIPTION:	ΓΩΝΙΑ ΣΥΝΔΕΣΗΣ ΠΡΕΣΑΡΙΣΤΗ PRESS CORNER	
ΥΛΙΚΟ: MATERIAL:	ΑΛΟΥΜΙΝΙΟ ALUMINIUM	ΣΥΣΚΕΥΑΣΙΑ: PACKAGE:
ΚΩΔΙΚΟΙ: ART No:	115-15-076-00, 115-15-400-00	ΧΡΩΜΑ: COLOR:
		ΑΒΑΦΟ MILL FINISH

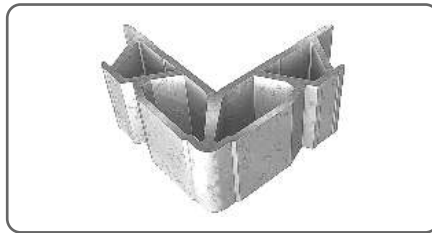

ΚΩΔΙΚΟΣ : ART. No :	115-23-***_**	STOCK No :
ΠΕΡΙΓΡΑΦΗ: DESCRIPTION:	ΓΩΝΙΑ ΣΥΝΔΕΣΗΣ ΠΡΕΣΑΡΙΣΤΗ PRESS CORNER	
ΥΛΙΚΟ: MATERIAL:	ΑΛΟΥΜΙΝΙΟ ALUMINIUM	ΣΥΣΚΕΥΑΣΙΑ: PACKAGE:
ΚΩΔΙΚΟΙ: ART No:	115-23-270-00, 115-23-400-00, 115-23-416-00,	ΧΡΩΜΑ: COLOR:
		ΑΒΑΦΟ MILL FINISH

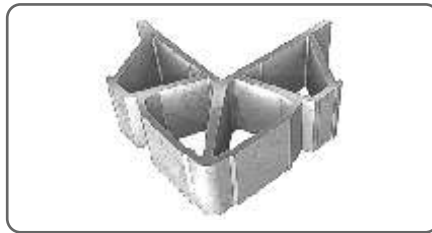

ΚΩΔΙΚΟΣ : ART. No :	115-33-***_**	STOCK No :
ΠΕΡΙΓΡΑΦΗ: DESCRIPTION:	ΓΩΝΙΑ ΣΥΝΔΕΣΗΣ ΠΡΕΣΑΡΙΣΤΗ PRESS CORNER	
ΥΛΙΚΟ: MATERIAL:	ΑΛΟΥΜΙΝΙΟ ALUMINIUM	ΣΥΣΚΕΥΑΣΙΑ: PACKAGE:
ΚΩΔΙΚΟΙ: ART No:	115-33-074-00, 115-33-464-00, 115-33-554-00	ΧΡΩΜΑ: COLOR:
		ΑΒΑΦΟ MILL FINISH

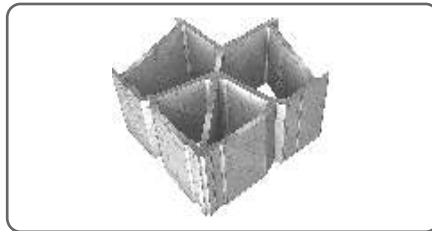

ΚΩΔΙΚΟΣ : ART. No :	115-43-***_**	STOCK No :
ΠΕΡΙΓΡΑΦΗ: DESCRIPTION:	ΓΩΝΙΑ ΣΥΝΔΕΣΗΣ ΠΡΕΣΑΡΙΣΤΗ PRESS CORNER	
ΥΛΙΚΟ: MATERIAL:	ΑΛΟΥΜΙΝΙΟ ALUMINIUM	ΣΥΣΚΕΥΑΣΙΑ: PACKAGE:
ΚΩΔΙΚΟΙ: ART No:	115-43-389-00, 115-43-400-00	ΧΡΩΜΑ: COLOR:
		ΑΒΑΦΟ

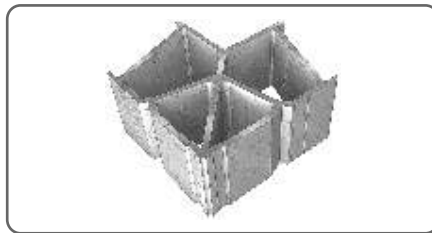

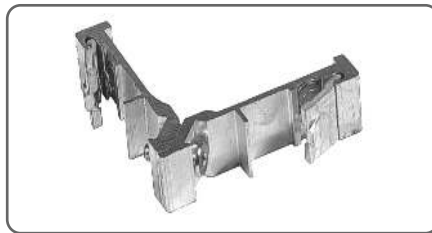

ΚΩΔΙΚΟΣ : ART. No :	115-57-***_**	STOCK No :
ΠΕΡΙΓΡΑΦΗ: DESCRIPTION:	ΓΩΝΙΑ ΣΥΝΔΕΣΗΣ ΠΡΕΣΑΡΙΣΤΗ PRESS CORNER	
ΥΛΙΚΟ: MATERIAL:	ΑΛΟΥΜΙΝΙΟ ALUMINIUM	ΣΥΣΚΕΥΑΣΙΑ: PACKAGE:
ΚΩΔΙΚΟΙ: ART No:	115-57-383-00, 115-57-400-00, 115-57-460-00	ΧΡΩΜΑ: COLOR:
		ΑΒΑΦΟ MILL FINISH

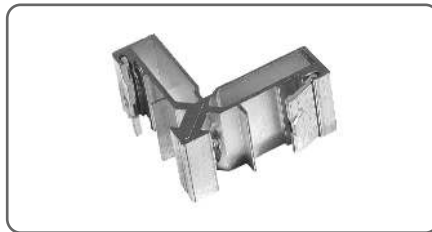

ΚΩΔΙΚΟΣ : ART. No :	120-13-***_**	STOCK No :
ΠΕΡΙΓΡΑΦΗ: DESCRIPTION:	ΓΩΝΙΑ ΣΥΝΔΕΣΗΣ ΒΙΔΩΤΗ SCREW CORNER	
ΥΛΙΚΟ: MATERIAL:	ΑΛΟΥΜΙΝΙΟ ALUMINIUM	ΣΥΣΚΕΥΑΣΙΑ: PACKAGE:
ΚΩΔΙΚΟΙ: ART No:	120-13-400-00, 120-13-464-00, 120-13-554-00	ΧΡΩΜΑ: COLOR:
		ΑΒΑΦΟ MILL FINISH

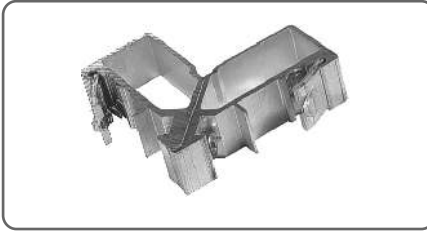

ΚΩΔΙΚΟΣ : ART. No :	120-23-***_**	STOCK No :
ΠΕΡΙΓΡΑΦΗ: DESCRIPTION:	ΓΩΝΙΑ ΣΥΝΔΕΣΗΣ ΒΙΔΩΤΗ SCREW CORNER	
ΥΛΙΚΟ: MATERIAL:	ΑΛΟΥΜΙΝΙΟ ALUMINIUM	ΣΥΣΚΕΥΑΣΙΑ: PACKAGE:
ΚΩΔΙΚΟΙ: ART No:	120-23-383-00, 120-23-400-00, 120-23-416-00,	ΧΡΩΜΑ: COLOR:
		ΑΒΑΦΟ MILL FINISH

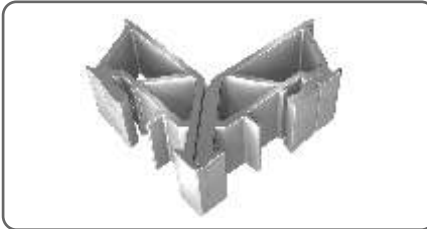
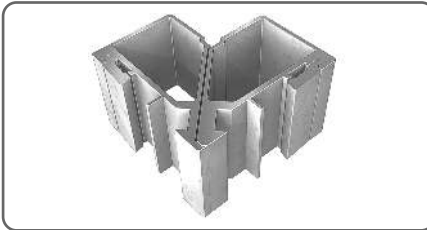
STOCK No :		ΚΩΔΙΚΟΣ : ART. No :	120-33-***_**	
ΠΕΡΙΓΡΑΦΗ: DESCRIPTION:	ΓΩΝΙΑ ΣΥΝΔΕΣΗΣ ΒΙΔΩΤΗ SCREW CORNER			
ΥΛΙΚΟ: MATERIAL:	ΑΛΟΥΜΙΝΙΟ ALUMINIUM	ΣΥΣΚΕΥΑΣΙΑ: PACKAGE:		
ΚΩΔΙΚΟΙ: ART No:	120-33-464-00, 120-33-554-00	ΧΡΩΜΑ: COLOR:	ΑΒΑΦΟ MILL FINISH	
STOCK No :		ΚΩΔΙΚΟΣ : ART. No :	120-43-***_**	
ΠΕΡΙΓΡΑΦΗ: DESCRIPTION:	ΓΩΝΙΑ ΣΥΝΔΕΣΗΣ ΒΙΔΩΤΗ SCREW CORNER			
ΥΛΙΚΟ: MATERIAL:	ΑΛΟΥΜΙΝΙΟ ALUMINIUM	ΣΥΣΚΕΥΑΣΙΑ: PACKAGE:		
ΚΩΔΙΚΟΙ: ART No:	120-43-389-00, 120-43-400-00	ΧΡΩΜΑ: COLOR:	ΑΒΑΦΟ MILL FINISH	
STOCK No :		ΚΩΔΙΚΟΣ : ART. No :	125-13-***_**	
ΠΕΡΙΓΡΑΦΗ: DESCRIPTION:	ΓΩΝΙΑ ΣΥΝΔΕΣΗΣ ΒΙΔΩΤΗ SCREW CORNER			
ΥΛΙΚΟ: MATERIAL:	ΑΛΟΥΜΙΝΙΟ ALUMINIUM	ΣΥΣΚΕΥΑΣΙΑ: PACKAGE:		
ΚΩΔΙΚΟΙ: ART No:	125-13-400-00, 125-13-464-00, 125-13-554-00	ΧΡΩΜΑ: COLOR:	ΑΒΑΦΟ MILL FINISH	
STOCK No :		ΚΩΔΙΚΟΣ : ART. No :	125-23-***_**	
ΠΕΡΙΓΡΑΦΗ: DESCRIPTION:	ΓΩΝΙΑ ΣΥΝΔΕΣΗΣ ΒΙΔΩΤΗ SCREW CORNER			
ΥΛΙΚΟ: MATERIAL:	ΑΛΟΥΜΙΝΙΟ ALUMINIUM	ΣΥΣΚΕΥΑΣΙΑ: PACKAGE:		
ΚΩΔΙΚΟΙ: ART No:	125-23-383-00, 125-23-400-00, 125-23-416-00,	ΧΡΩΜΑ: COLOR:	ΑΒΑΦΟ MILL FINISH	
STOCK No :		ΚΩΔΙΚΟΣ : ART. No :	125-33-***_**	
ΠΕΡΙΓΡΑΦΗ: DESCRIPTION:	ΓΩΝΙΑ ΣΥΝΔΕΣΗΣ ΒΙΔΩΤΗ SCREW CORNER			
ΥΛΙΚΟ: MATERIAL:	ΑΛΟΥΜΙΝΙΟ ALUMINIUM	ΣΥΣΚΕΥΑΣΙΑ: PACKAGE:		
ΚΩΔΙΚΟΙ: ART No:	125-33-464-00, 125-33-554-00	ΧΡΩΜΑ: COLOR:	ΑΒΑΦΟ MILL FINISH	
STOCK No :		ΚΩΔΙΚΟΣ : ART. No :	125-43-***_**	
ΠΕΡΙΓΡΑΦΗ: DESCRIPTION:	ΓΩΝΙΑ ΣΥΝΔΕΣΗΣ ΒΙΔΩΤΗ SCREW CORNER			
ΥΛΙΚΟ: MATERIAL:	ΑΛΟΥΜΙΝΙΟ ALUMINIUM	ΣΥΣΚΕΥΑΣΙΑ: PACKAGE:		
ΚΩΔΙΚΟΙ: ART No:	125-43-389-00, 125-43-400-00	ΧΡΩΜΑ: COLOR:	ΑΒΑΦΟ MILL FINISH	
STOCK No :		ΚΩΔΙΚΟΣ : ART. No :	130-13-074-00	
ΠΕΡΙΓΡΑΦΗ: DESCRIPTION:	ΓΩΝΙΑ ΣΥΝΔΕΣΗΣ ΜΕ ΠΕΙΡΟ NAIL CORNER			
ΥΛΙΚΟ: MATERIAL:	ΑΛΟΥΜΙΝΙΟ ALUMINIUM	ΣΥΣΚΕΥΑΣΙΑ: PACKAGE:		
ΚΩΔΙΚΟΙ: ART No:		ΧΡΩΜΑ: COLOR:	ΑΒΑΦΟ MILL FINISH	
STOCK No :		ΚΩΔΙΚΟΣ : ART. No :	130-15-076-00	
ΠΕΡΙΓΡΑΦΗ: DESCRIPTION:	ΓΩΝΙΑ ΣΥΝΔΕΣΗΣ ΜΕ ΠΕΙΡΟ NAIL CORNER			
ΥΛΙΚΟ: MATERIAL:	ΑΛΟΥΜΙΝΙΟ ALUMINIUM	ΣΥΣΚΕΥΑΣΙΑ: PACKAGE:		
ΚΩΔΙΚΟΙ: ART No:		ΧΡΩΜΑ: COLOR:	ΑΒΑΦΟ MILL FINISH	

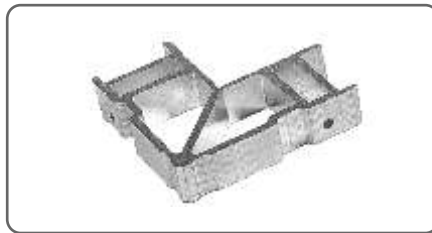

ΚΩΔΙΚΟΣ : 130-33-074-00 **STOCK No :**

ART. No : 130-33-074-00
ΠΕΡΙΓΡΑΦΗ: ΓΩΝΙΑ ΣΥΝΔΕΣΗΣ ΜΕ ΠΕΙΡΟ
DESCRIPTION: NAIL CORNER

ΥΛΙΚΟ: ΑΛΟΥΜΙΝΙΟ
MATERIAL: ALUMINIUM

ΣΥΣΚΕΥΑΣΙΑ:
PACKAGE:

ΧΡΩΜΑ: ΑΒΑΦΟ
COLOR: MILL FINISH

ΔΙΑΣΤΑΣΗ:
DIMENSION:



ΚΩΔΙΚΟΣ : 140-00-219-00 **STOCK No :**

ART. No : 140-00-219-00
ΠΕΡΙΓΡΑΦΗ: ΓΩΝΙΑ ΣΥΝΔΕΣΗΣ ΒΙΔΩΤΗ
DESCRIPTION: SCREW CORNER

ΥΛΙΚΟ: ΑΤΣΑΛΙ
MATERIAL: STEEL

ΣΥΣΚΕΥΑΣΙΑ: 100 - 400
PACKAGE:

ΧΡΩΜΑ: ΑΒΑΦΟ
COLOR: MILL FINISH

ΔΙΑΣΤΑΣΗ:
DIMENSION:



ΚΩΔΙΚΟΣ : 140-23-420-00 **STOCK No :** MON325

ART. No : 140-23-420-00
ΠΕΡΙΓΡΑΦΗ: ΓΩΝΙΑ ΣΥΝΔΕΣΗΣ ΒΙΔΩΤΗ - ΧΥΤΗ
DESCRIPTION: SCREW CORNER

ΥΛΙΚΟ: ΧΥΤΟ ΑΛΟΥΜΙΝΙΟ
MATERIAL: DIE-CAST ALUMINIUM

ΣΥΣΚΕΥΑΣΙΑ:
PACKAGE:

ΧΡΩΜΑ: ΑΒΑΦΟ
COLOR: MILL FINISH

ΔΙΑΣΤΑΣΗ: 23 X 42 mm
DIMENSION:

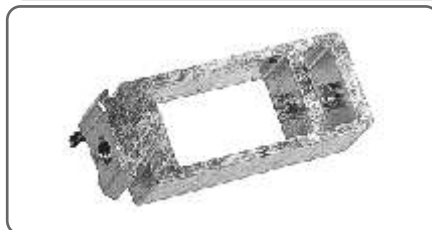

ΚΩΔΙΚΟΣ : 160-11-213-00 **STOCK No :**

ART. No : 160-11-213-00
ΠΕΡΙΓΡΑΦΗ: ΣΥΝΔΕΣΜΟΣ ΤΑΦ ΕΣΩΤΕΡΙΚΟΣ
DESCRIPTION: T - CONNECTOR

ΥΛΙΚΟ: ΑΛΟΥΜΙΝΙΟ
MATERIAL: ALUMINIUM

ΣΥΣΚΕΥΑΣΙΑ: 450
PACKAGE:

ΧΡΩΜΑ: ΑΒΑΦΟ
COLOR: MILL FINISH

ΔΙΑΣΤΑΣΗ:
DIMENSION:



ΚΩΔΙΚΟΣ : 160-11-221-00 **STOCK No :**

ART. No : 160-11-221-00
ΠΕΡΙΓΡΑΦΗ: ΣΥΝΔΕΣΜΟΣ ΤΑΦ ΕΣΩΤΕΡΙΚΟΣ
DESCRIPTION: T - CONNECTOR

ΥΛΙΚΟ: ΑΛΟΥΜΙΝΙΟ
MATERIAL: ALUMINIUM

ΣΥΣΚΕΥΑΣΙΑ: 400
PACKAGE:

ΧΡΩΜΑ: ΑΒΑΦΟ
COLOR: MILL FINISH

ΔΙΑΣΤΑΣΗ:
DIMENSION:

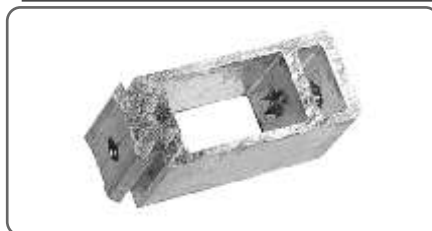

ΚΩΔΙΚΟΣ : 160-11-223-00 **STOCK No :**

ART. No : 160-11-223-00
ΠΕΡΙΓΡΑΦΗ: ΣΥΝΔΕΣΜΟΣ ΤΑΦ ΕΣΩΤΕΡΙΚΟΣ
DESCRIPTION: T - CONNECTOR

ΥΛΙΚΟ: ΑΛΟΥΜΙΝΙΟ
MATERIAL: ALUMINIUM

ΣΥΣΚΕΥΑΣΙΑ: 300
PACKAGE:

ΧΡΩΜΑ: ΑΒΑΦΟ
COLOR: MILL FINISH

ΔΙΑΣΤΑΣΗ:
DIMENSION:



ΚΩΔΙΚΟΣ : 160-11-233-00 **STOCK No :**

ART. No : 160-11-233-00
ΠΕΡΙΓΡΑΦΗ: ΣΥΝΔΕΣΜΟΣ ΤΑΦ ΕΣΩΤΕΡΙΚΟΣ
DESCRIPTION: T - CONNECTOR

ΥΛΙΚΟ: ΑΛΟΥΜΙΝΙΟ
MATERIAL: ALUMINIUM

ΣΥΣΚΕΥΑΣΙΑ: 200
PACKAGE:

ΧΡΩΜΑ: ΑΒΑΦΟ
COLOR: MILL FINISH

ΔΙΑΣΤΑΣΗ:
DIMENSION:

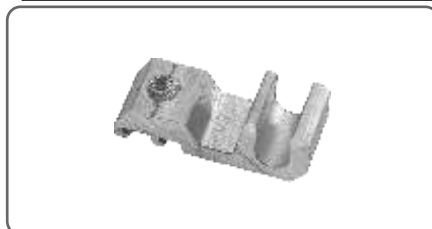

ΚΩΔΙΚΟΣ : 160-11-813-00 **STOCK No :**

ART. No : 160-11-813-00
ΠΕΡΙΓΡΑΦΗ: ΣΥΝΔΕΣΜΟΣ ΤΑΦ ΕΣΩΤΕΡΙΚΟΣ
DESCRIPTION: T - CONNECTOR

ΥΛΙΚΟ: ΑΛΟΥΜΙΝΙΟ
MATERIAL: ALUMINIUM

ΣΥΣΚΕΥΑΣΙΑ:
PACKAGE:

ΧΡΩΜΑ: ΑΒΑΦΟ
COLOR: MILL FINISH

ΔΙΑΣΤΑΣΗ:
DIMENSION:

STOCK No :		ΚΩΔΙΚΟΣ : ART. No :	160-11-821-00
ΠΕΡΙΓΡΑΦΗ: DESCRIPTION:	ΣΥΝΔΕΣΜΟΣ ΤΑΦ ΕΞΩΤΕΡΙΚΟΣ T - CONNECTOR		
ΥΛΙΚΟ: MATERIAL:	ΑΛΟΥΜΙΝΙΟ ALUMINIUM	ΣΥΣΚΕΥΑΣΙΑ: PACKAGE:	
ΧΡΩΜΑ: COLOR:	ΑΒΑΦΟ MILL FINISH	ΔΙΑΣΤΑΣΗ: DIMENSION:	

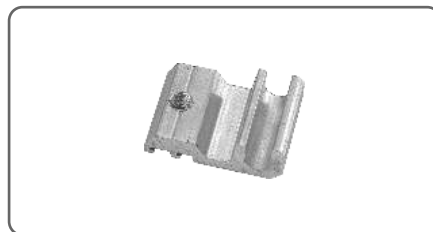

STOCK No :		ΚΩΔΙΚΟΣ : ART. No :	160-11-823-00
ΠΕΡΙΓΡΑΦΗ: DESCRIPTION:	ΣΥΝΔΕΣΜΟΣ ΤΑΦ ΕΞΩΤΕΡΙΚΟΣ T - CONNECTOR		
ΥΛΙΚΟ: MATERIAL:	ΑΛΟΥΜΙΝΙΟ ALUMINIUM	ΣΥΣΚΕΥΑΣΙΑ: PACKAGE:	
ΧΡΩΜΑ: COLOR:	ΑΒΑΦΟ MILL FINISH	ΔΙΑΣΤΑΣΗ: DIMENSION:	

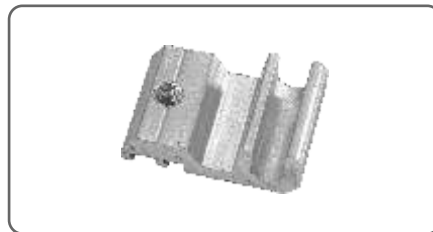

STOCK No :		ΚΩΔΙΚΟΣ : ART. No :	160-11-833-00
ΠΕΡΙΓΡΑΦΗ: DESCRIPTION:	ΣΥΝΔΕΣΜΟΣ ΤΑΦ ΕΞΩΤΕΡΙΚΟΣ T - CONNECTOR		
ΥΛΙΚΟ: MATERIAL:	ΑΛΟΥΜΙΝΙΟ ALUMINIUM	ΣΥΣΚΕΥΑΣΙΑ: PACKAGE:	
ΧΡΩΜΑ: COLOR:	ΑΒΑΦΟ MILL FINISH	ΔΙΑΣΤΑΣΗ: DIMENSION:	

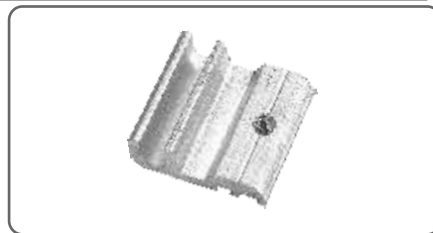

STOCK No :		ΚΩΔΙΚΟΣ : ART. No :	165-11-001-00
ΠΕΡΙΓΡΑΦΗ: DESCRIPTION:	ΣΥΝΔΕΣΜΟΣ ΤΑΦ ΕΞΩΤΕΡΙΚΟΣ ΔΕΞΙΟΣ T - CONNECTOR		
ΥΛΙΚΟ: MATERIAL:	ΧΥΤΟ ΑΛΟΥΜΙΝΙΟ DIE-CAST ALUMINIUM	ΣΥΣΚΕΥΑΣΙΑ: 1 PACKAGE:	
ΧΡΩΜΑ: COLOR:	ΑΒΑΦΟ MILL FINISH	ΔΙΑΣΤΑΣΗ: DIMENSION:	



STOCK No :		ΚΩΔΙΚΟΣ : ART. No :	165-11-002-00
ΠΕΡΙΓΡΑΦΗ: DESCRIPTION:	ΣΥΝΔΕΣΜΟΣ ΤΑΦ ΕΞΩΤΕΡΙΚΟΣ ΑΡΙΣΤΕΡΟΣ T - CONNECTOR		
ΥΛΙΚΟ: MATERIAL:	ΧΥΤΟ ΑΛΟΥΜΙΝΙΟ DIE-CAST ALUMINIUM	ΣΥΣΚΕΥΑΣΙΑ: 1 PACKAGE:	
ΧΡΩΜΑ: COLOR:	ΑΒΑΦΟ MILL FINISH	ΔΙΑΣΤΑΣΗ: DIMENSION:	

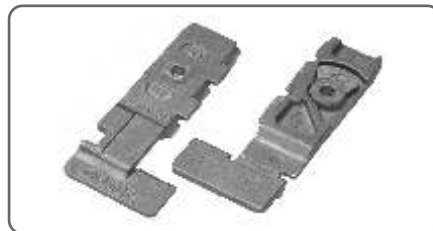

STOCK No :		ΚΩΔΙΚΟΣ : ART. No :	165-47-130-00
ΠΕΡΙΓΡΑΦΗ: DESCRIPTION:	ΣΥΝΔΕΣΜΟΣ ΤΑΦ ΕΣΩΤΕΡΙΚΟΣ T - CONNECTOR		
ΥΛΙΚΟ: MATERIAL:	ΧΥΤΟ ΑΛΟΥΜΙΝΙΟ DIE-CAST ALUMINIUM	ΣΥΣΚΕΥΑΣΙΑ: 1 PACKAGE:	
ΧΡΩΜΑ: COLOR:	ΑΒΑΦΟ MILL FINISH	ΔΙΑΣΤΑΣΗ: 47 X 13 mm DIMENSION:	



STOCK No :		ΚΩΔΙΚΟΣ : ART. No :	165-47-230-00
ΠΕΡΙΓΡΑΦΗ: DESCRIPTION:	ΣΥΝΔΕΣΜΟΣ ΤΑΦ ΕΣΩΤΕΡΙΚΟΣ T - CONNECTOR		
ΥΛΙΚΟ: MATERIAL:	ΧΥΤΟ ΑΛΟΥΜΙΝΙΟ DIE-CAST ALUMINIUM	ΣΥΣΚΕΥΑΣΙΑ: 1 PACKAGE:	
ΧΡΩΜΑ: COLOR:	ΑΒΑΦΟ MILL FINISH	ΔΙΑΣΤΑΣΗ: 47 X 23 mm DIMENSION:	



STOCK No :		ΚΩΔΙΚΟΣ : ART. No :	165-47-330-00
ΠΕΡΙΓΡΑΦΗ: DESCRIPTION:	ΣΥΝΔΕΣΜΟΣ ΤΑΦ ΕΣΩΤΕΡΙΚΟΣ T - CONNECTOR		
ΥΛΙΚΟ: MATERIAL:	ΧΥΤΟ ΑΛΟΥΜΙΝΙΟ DIE-CAST ALUMINIUM	ΣΥΣΚΕΥΑΣΙΑ: PACKAGE:	
ΧΡΩΜΑ: COLOR:	ΑΒΑΦΟ MILL FINISH	ΔΙΑΣΤΑΣΗ: 47 X 33 mm DIMENSION:	





ΚΩΔΙΚΟΣ : ART. No :	165-47-430-00	STOCK No :
ΠΕΡΙΓΡΑΦΗ: DESCRIPTION:	ΣΥΝΔΕΣΜΟΣ ΤΑΦ ΕΣΩΤΕΡΙΚΟΣ T - CONNECTOR	
ΥΛΙΚΟ: MATERIAL:	ΧΥΤΟ ΑΛΟΥΜΙΝΙΟ DIE-CAST ALUMINIUM	ΣΥΣΚΕΥΑΣΙΑ: PACKAGE: 1
ΧΡΩΜΑ: COLOR:	ΑΒΑΦΟ MILL FINISH	ΔΙΑΣΤΑΣΗ: DIMENSION: 47 X 43 mm



ΚΩΔΙΚΟΣ : ART. No :	165-55-130-00	STOCK No :
ΠΕΡΙΓΡΑΦΗ: DESCRIPTION:	ΣΥΝΔΕΣΜΟΣ ΤΑΦ ΕΣΩΤΕΡΙΚΟΣ T - CONNECTOR	
ΥΛΙΚΟ: MATERIAL:	ΧΥΤΟ ΑΛΟΥΜΙΝΙΟ DIE-CAST ALUMINIUM	ΣΥΣΚΕΥΑΣΙΑ: PACKAGE: 1
ΧΡΩΜΑ: COLOR:	ΑΒΑΦΟ MILL FINISH	ΔΙΑΣΤΑΣΗ: DIMENSION: 55 X 13 mm



ΚΩΔΙΚΟΣ : ART. No :	165-55-330-00	STOCK No :
ΠΕΡΙΓΡΑΦΗ: DESCRIPTION:	ΣΥΝΔΕΣΜΟΣ ΤΑΦ ΕΣΩΤΕΡΙΚΟΣ T - CONNECTOR	
ΥΛΙΚΟ: MATERIAL:	ΧΥΤΟ ΑΛΟΥΜΙΝΙΟ DIE-CAST ALUMINIUM	ΣΥΣΚΕΥΑΣΙΑ: PACKAGE: 1
ΧΡΩΜΑ: COLOR:	ΑΒΑΦΟ MILL FINISH	ΔΙΑΣΤΑΣΗ: DIMENSION: 55 X 33 mm



ΚΩΔΙΚΟΣ : ART. No :	165-00-001-00	STOCK No :
ΠΕΡΙΓΡΑΦΗ: DESCRIPTION:	ΟΔΗΓ. ΤΡΥΠΗΜ. ΤΑΦ ΓΙΑ ΧΥΤΟΥΣ ΣΥΝΔ. (ΣΑΜΠΛΟΝ) DRILLING GUIDE	
ΥΛΙΚΟ: MATERIAL:		ΣΥΣΚΕΥΑΣΙΑ: PACKAGE: 1
ΧΡΩΜΑ: COLOR:		ΔΙΑΣΤΑΣΗ: DIMENSION:



ΚΩΔΙΚΟΣ : ART. No :	470-11-835-00	STOCK No :
ΠΕΡΙΓΡΑΦΗ: DESCRIPTION:	ΠΕΙΡΟΣ ΓΙΑ ΣΥΝΔΕΣΜΟΥΣ Ø6 BREAK AWAY NAIL FOR T - CONNECTORS Ø6	
ΥΛΙΚΟ: MATERIAL:	ΧΥΤΟ ΑΛΟΥΜΙΝΙΟ DIE-CAST ALUMINIUM	ΣΥΣΚΕΥΑΣΙΑ: PACKAGE:
ΧΡΩΜΑ: COLOR:		ΔΙΑΣΤΑΣΗ: DIMENSION:





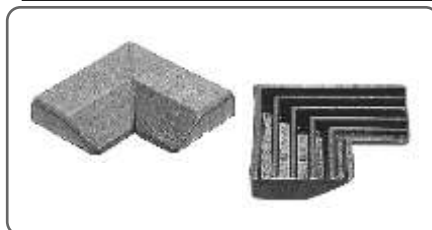



ΚΩΔΙΚΟΣ : ART. No :	470-11-836-00	STOCK No :
ΠΕΡΙΓΡΑΦΗ: DESCRIPTION:	ΠΕΙΡΟΣ ΓΙΑ ΣΥΝΔΕΣΜΟΥΣ Ø4 BREAK AWAY NAIL FOR T - CONNECTORS Ø4	
ΥΛΙΚΟ: MATERIAL:	ΧΥΤΟ ΑΛΟΥΜΙΝΙΟ DIE-CAST ALUMINIUM	ΣΥΣΚΕΥΑΣΙΑ: PACKAGE:
ΧΡΩΜΑ: COLOR:		ΔΙΑΣΤΑΣΗ: DIMENSION:



ΚΩΔΙΚΟΣ : ART. No :	180-00-550-00	STOCK No :
ΠΕΡΙΓΡΑΦΗ: DESCRIPTION:	ΓΩΝΙΑ ΕΠΙΠΕΔΟΤΗΤΑΣ ALIGNMENT CORNER	
ΥΛΙΚΟ: MATERIAL:	ΠΟΛΥΑΜΙΔΙΟ POLYAMIDE	ΣΥΣΚΕΥΑΣΙΑ: PACKAGE: 300
ΧΡΩΜΑ: COLOR:	ΜΑΥΡΟ BLACK	ΔΙΑΣΤΑΣΗ: DIMENSION:

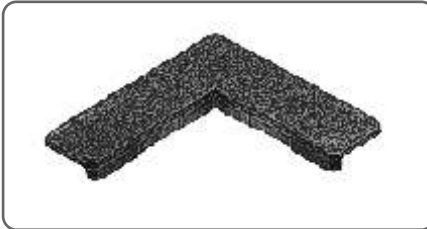
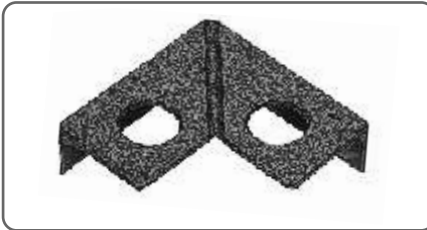
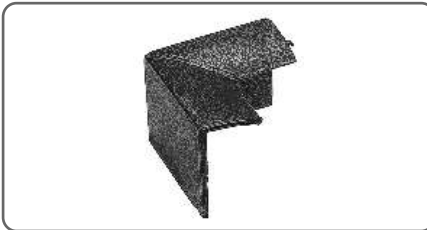

ΚΩΔΙΚΟΣ : ART. No :	180-11-062-00	STOCK No :
ΠΕΡΙΓΡΑΦΗ: DESCRIPTION:	ΓΩΝΙΑ ΕΠΙΠΕΔΟΤΗΤΑΣ ALIGNMENT CORNER	
ΥΛΙΚΟ: MATERIAL:	ΠΟΛΥΑΜΙΔΙΟ POLYAMIDE	ΣΥΣΚΕΥΑΣΙΑ: PACKAGE: 800
ΧΡΩΜΑ: COLOR:	ΜΑΥΡΟ BLACK	ΔΙΑΣΤΑΣΗ: DIMENSION:

STOCK No :		ΚΩΔΙΚΟΣ : ART. No :	180-11-118-00	
ΠΕΡΙΓΡΑΦΗ: DESCRIPTION:	ΓΩΝΙΑ ΕΠΙΠΕΔΟΤΗΤΑΣ ALIGNMENT CORNER			
ΥΛΙΚΟ: MATERIAL:	ΠΟΛΥΑΜΙΔΙΟ POLYAMIDE	ΣΥΣΚΕΥΑΣΙΑ: PACKAGE:		
ΧΡΩΜΑ: COLOR:	ΜΑΥΡΟ BLACK	ΔΙΑΣΤΑΣΗ: DIMENSION:		
STOCK No :		ΚΩΔΙΚΟΣ : ART. No :	180-11-119-00	
ΠΕΡΙΓΡΑΦΗ: DESCRIPTION:	ΓΩΝΙΑ ΕΠΙΠΕΔΟΤΗΤΑΣ ALIGNMENT CORNER			
ΥΛΙΚΟ: MATERIAL:	ΠΟΛΥΑΜΙΔΙΟ POLYAMIDE	ΣΥΣΚΕΥΑΣΙΑ: 600 PACKAGE:		
ΧΡΩΜΑ: COLOR:	ΜΑΥΡΟ BLACK	ΔΙΑΣΤΑΣΗ: DIMENSION:		
STOCK No :		ΚΩΔΙΚΟΣ : ART. No :	180-11-408-00	
ΠΕΡΙΓΡΑΦΗ: DESCRIPTION:	ΓΩΝΙΑ ΕΠΙΠΕΔΟΤΗΤΑΣ ALIGNMENT CORNER			
ΥΛΙΚΟ: MATERIAL:	ΠΟΛΥΑΜΙΔΙΟ POLYAMIDE	ΣΥΣΚΕΥΑΣΙΑ: 250 PACKAGE:		
ΧΡΩΜΑ: COLOR:	ΜΑΥΡΟ BLACK	ΔΙΑΣΤΑΣΗ: DIMENSION:		
STOCK No :		ΚΩΔΙΚΟΣ : ART. No :	180-11-801-00	
ΠΕΡΙΓΡΑΦΗ: DESCRIPTION:	ΓΩΝΙΑ ΕΠΙΠΕΔΟΤΗΤΑΣ ALIGNMENT CORNER			
ΥΛΙΚΟ: MATERIAL:	ΠΟΛΥΑΜΙΔΙΟ POLYAMIDE	ΣΥΣΚΕΥΑΣΙΑ: 4000 PACKAGE:		
ΧΡΩΜΑ: COLOR:	ΜΑΥΡΟ BLACK	ΔΙΑΣΤΑΣΗ: DIMENSION:		
STOCK No :		ΚΩΔΙΚΟΣ : ART. No :	180-15-004-00	
ΠΕΡΙΓΡΑΦΗ: DESCRIPTION:	ΓΩΝΙΑ ΕΠΙΠΕΔΟΤΗΤΑΣ ALIGNMENT CORNER			
ΥΛΙΚΟ: MATERIAL:	ΠΟΛΥΑΜΙΔΙΟ POLYAMIDE	ΣΥΣΚΕΥΑΣΙΑ: 1000 PACKAGE:		
ΧΡΩΜΑ: COLOR:	ΜΑΥΡΟ BLACK	ΔΙΑΣΤΑΣΗ: DIMENSION:		
STOCK No :		ΚΩΔΙΚΟΣ : ART. No :	180-15-006-00	
ΠΕΡΙΓΡΑΦΗ: DESCRIPTION:	ΓΩΝΙΑ ΕΠΙΠΕΔΟΤΗΤΑΣ ALIGNMENT CORNER			
ΥΛΙΚΟ: MATERIAL:	ΠΟΛΥΑΜΙΔΙΟ POLYAMIDE	ΣΥΣΚΕΥΑΣΙΑ: 450 PACKAGE:		
ΧΡΩΜΑ: COLOR:	ΜΑΥΡΟ BLACK	ΔΙΑΣΤΑΣΗ: DIMENSION:		
STOCK No :		ΚΩΔΙΚΟΣ : ART. No :	180-15-007-00	
ΠΕΡΙΓΡΑΦΗ: DESCRIPTION:	ΓΩΝΙΑ ΕΠΙΠΕΔΟΤΗΤΑΣ ALIGNMENT CORNER			
ΥΛΙΚΟ: MATERIAL:	ΠΟΛΥΑΜΙΔΙΟ POLYAMIDE	ΣΥΣΚΕΥΑΣΙΑ: 200 PACKAGE:		
ΧΡΩΜΑ: COLOR:	ΜΑΥΡΟ BLACK	ΔΙΑΣΤΑΣΗ: DIMENSION:		
STOCK No :		ΚΩΔΙΚΟΣ : ART. No :	180-15-015-00	
ΠΕΡΙΓΡΑΦΗ: DESCRIPTION:	ΓΩΝΙΑ ΕΠΙΠΕΔΟΤΗΤΑΣ ALIGNMENT CORNER			
ΥΛΙΚΟ: MATERIAL:	ΠΟΛΥΑΜΙΔΙΟ POLYAMIDE	ΣΥΣΚΕΥΑΣΙΑ: 450 PACKAGE:		
ΧΡΩΜΑ: COLOR:	ΜΑΥΡΟ BLACK	ΔΙΑΣΤΑΣΗ: DIMENSION:		

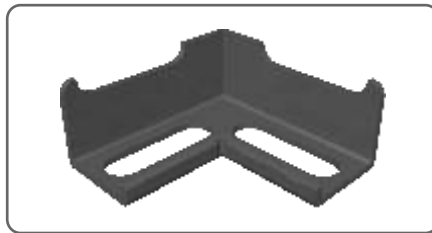

ΚΩΔΙΚΟΣ : ART. No :	180-15-022-00	STOCK No :
ΠΕΡΙΓΡΑΦΗ: DESCRIPTION:	ΓΩΝΙΑ ΕΠΙΠΕΔΟΤΗΤΑΣ ΓΩΝΙΑΚΗΣ ΚΑΣΑΣ ALIGNMENT CORNER	
ΥΛΙΚΟ: MATERIAL:	ΠΟΛΥΑΜΙΔΙΟ POLYAMIDE	ΣΥΣΚΕΥΑΣΙΑ: PACKAGE:
ΧΡΩΜΑ: COLOR:	ΜΑΥΡΟ BLACK	ΔΙΑΣΤΑΣΗ: DIMENSION:



ΚΩΔΙΚΟΣ : ART. No :	180-15-026-00	STOCK No :
ΠΕΡΙΓΡΑΦΗ: DESCRIPTION:	ΓΩΝΙΑ ΕΠΙΠΕΔΟΤΗΤΑΣ ALIGNMENT CORNER	
ΥΛΙΚΟ: MATERIAL:	ΠΟΛΥΑΜΙΔΙΟ POLYAMIDE	ΣΥΣΚΕΥΑΣΙΑ: 350 PACKAGE:
ΧΡΩΜΑ: COLOR:	ΜΑΥΡΟ BLACK	ΔΙΑΣΤΑΣΗ: DIMENSION:



ΚΩΔΙΚΟΣ : ART. No :	180-15-050-00	STOCK No :
ΠΕΡΙΓΡΑΦΗ: DESCRIPTION:	ΓΩΝΙΑ ΕΠΙΠΕΔΟΤΗΤΑΣ ΓΩΝΙΑΚΟΥ ΦΥΛΛΟΥ ALIGNMENT CORNER	
ΥΛΙΚΟ: MATERIAL:	ΠΟΛΥΑΜΙΔΙΟ POLYAMIDE	ΣΥΣΚΕΥΑΣΙΑ: PACKAGE:
ΧΡΩΜΑ: COLOR:	ΜΑΥΡΟ BLACK	ΔΙΑΣΤΑΣΗ: DIMENSION:

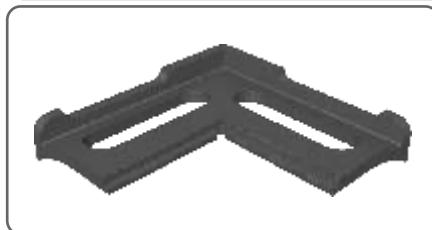

ΚΩΔΙΚΟΣ : ART. No :	180-15-250-00	STOCK No :
ΠΕΡΙΓΡΑΦΗ: DESCRIPTION:	ΓΩΝΙΑ ΕΠΙΠΕΔΟΤΗΤΑΣ ΦΥΛΛΟΥ ALIGNMENT CORNER	
ΥΛΙΚΟ: MATERIAL:	ΠΟΛΥΑΜΙΔΙΟ POLYAMIDE	ΣΥΣΚΕΥΑΣΙΑ: PACKAGE:
ΧΡΩΜΑ: COLOR:	ΜΑΥΡΟ BLACK	ΔΙΑΣΤΑΣΗ: DIMENSION:

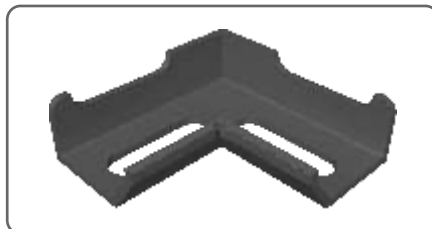

ΚΩΔΙΚΟΣ : ART. No :	180-15-324-00	STOCK No :
ΠΕΡΙΓΡΑΦΗ: DESCRIPTION:	ΓΩΝΙΑ ΕΠΙΠΕΔΟΤΗΤΑΣ ΦΥΛΛΟΥ ALIGNMENT CORNER	
ΥΛΙΚΟ: MATERIAL:	ΠΟΛΥΑΜΙΔΙΟ POLYAMIDE	ΣΥΣΚΕΥΑΣΙΑ: PACKAGE:
ΧΡΩΜΑ: COLOR:	ΜΑΥΡΟ BLACK	ΔΙΑΣΤΑΣΗ: DIMENSION:

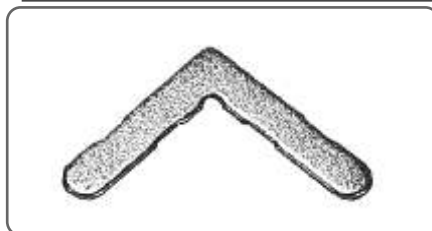

ΚΩΔΙΚΟΣ : ART. No :	180-19-000-00	STOCK No :
ΠΕΡΙΓΡΑΦΗ: DESCRIPTION:	ΓΩΝΙΑ ΕΠΙΠΕΔΟΤΗΤΑΣ ALIGNMENT CORNER	
ΥΛΙΚΟ: MATERIAL:	ΑΤΣΑΛΙ STEEL	ΣΥΣΚΕΥΑΣΙΑ: 1 - 20 X 500 PACKAGE:
ΧΡΩΜΑ: COLOR:		ΔΙΑΣΤΑΣΗ: DIMENSION:

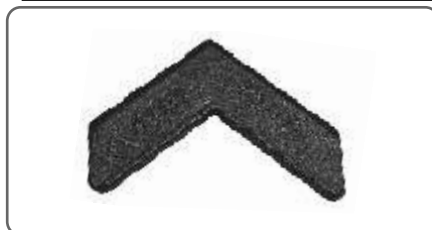

ΚΩΔΙΚΟΣ : ART. No :	180-20-000-00	STOCK No :
ΠΕΡΙΓΡΑΦΗ: DESCRIPTION:	ΓΩΝΙΑ ΕΠΙΠΕΔΟΤΗΤΑΣ ALIGNMENT CORNER	
ΥΛΙΚΟ: MATERIAL:	ΠΟΛΥΑΜΙΔΙΟ POLYAMIDE	ΣΥΣΚΕΥΑΣΙΑ: 2000 PACKAGE:
ΧΡΩΜΑ: COLOR:	ΜΑΥΡΟ BLACK	ΔΙΑΣΤΑΣΗ: DIMENSION:



ΚΩΔΙΚΟΣ : ART. No :	180-25-005-00	STOCK No :
ΠΕΡΙΓΡΑΦΗ: DESCRIPTION:	ΓΩΝΙΑ ΕΠΙΠΕΔΟΤΗΤΑΣ ALIGNMENT CORNER	
ΥΛΙΚΟ: MATERIAL:	ΠΟΛΥΑΜΙΔΙΟ POLYAMIDE	ΣΥΣΚΕΥΑΣΙΑ: 1000 PACKAGE:
ΧΡΩΜΑ: COLOR:	ΜΑΥΡΟ BLACK	ΔΙΑΣΤΑΣΗ: DIMENSION:

STOCK No :		ΚΩΔΙΚΟΣ : ART. No :	180-25-010-00
ΠΕΡΙΓΡΑΦΗ: DESCRIPTION:	ΓΩΝΙΑ ΕΠΙΠΕΔΟΤΗΤΑΣ ALIGNMENT CORNER		
ΥΛΙΚΟ: MATERIAL:	ΠΟΛΥΑΜΙΔΙΟ POLYAMIDE	ΣΥΣΚΕΥΑΣΙΑ: PACKAGE:	600
ΧΡΩΜΑ: COLOR:	ΜΑΥΡΟ BLACK	ΔΙΑΣΤΑΣΗ: DIMENSION:	



STOCK No :		ΚΩΔΙΚΟΣ : ART. No :	180-25-025-00
ΠΕΡΙΓΡΑΦΗ: DESCRIPTION:	ΓΩΝΙΑ ΕΠΙΠΕΔΟΤΗΤΑΣ ALIGNMENT CORNER		
ΥΛΙΚΟ: MATERIAL:	ΠΟΛΥΑΜΙΔΙΟ POLYAMIDE	ΣΥΣΚΕΥΑΣΙΑ: PACKAGE:	200
ΧΡΩΜΑ: COLOR:	ΜΑΥΡΟ BLACK	ΔΙΑΣΤΑΣΗ: DIMENSION:	



STOCK No :		ΚΩΔΙΚΟΣ : ART. No :	170-60-562-00
ΠΕΡΙΓΡΑΦΗ: DESCRIPTION:	ΓΩΝΙΑ ΚΑΜΠΥΛΩΤΟΥ ΚΟΥΜΠΩΜΑΤΟΣ CORNER PIECE FOR GLAZING BEAD		
ΥΛΙΚΟ: MATERIAL:	ΧΥΤΟ ΑΛΟΥΜΙΝΙΟ DIE CAST ALUMINIUM	ΣΥΣΚΕΥΑΣΙΑ: PACKAGE:	100 - 400
ΧΡΩΜΑ: COLOR:	ΑΒΑΦΟ / MILL FINISH, 170-60-562-02 ΛΕΥΚΟ / WHITE, 170-60-562-03 ΜΑΥΡΟ / BLACK, 170-60-562-06 ΚΑΦΕ / BROWN		



STOCK No :		ΚΩΔΙΚΟΣ : ART. No :	170-60-563-00
ΠΕΡΙΓΡΑΦΗ: DESCRIPTION:	ΓΩΝΙΑ ΚΑΜΠΥΛΩΤΟΥ ΚΟΥΜΠΩΜΑΤΟΣ CORNER PIECE FOR ROUND GLAZING BEAD		
ΥΛΙΚΟ: MATERIAL:	ΧΥΤΟ ΑΛΟΥΜΙΝΙΟ DIE CAST ALUMINIUM	ΣΥΣΚΕΥΑΣΙΑ: PACKAGE:	100 - 400
ΧΡΩΜΑ: COLOR:	ΑΒΑΦΟ / MILL FINISH, 170-60-563-02 ΛΕΥΚΟ / WHITE, 170-60-563-03 ΜΑΥΡΟ / BLACK, 170-60-563-06 ΚΑΦΕ / BROWN		



STOCK No :		ΚΩΔΙΚΟΣ : ART. No :	170-60-564-00
ΠΕΡΙΓΡΑΦΗ: DESCRIPTION:	ΓΩΝΙΑ ΚΑΜΠΥΛΩΤΟΥ ΚΟΥΜΠΩΜΑΤΟΣ CORNER PIECE FOR ROUND GLAZING BEAD		
ΥΛΙΚΟ: MATERIAL:	ΧΥΤΟ ΑΛΟΥΜΙΝΙΟ DIE CAST ALUMINIUM	ΣΥΣΚΕΥΑΣΙΑ: PACKAGE:	100 - 400
ΧΡΩΜΑ: COLOR:	ΑΒΑΦΟ / MILL FINISH, 170-60-564-02 ΛΕΥΚΟ / WHITE, 170-60-564-03 ΜΑΥΡΟ / BLACK, 170-60-564-06 / ΚΑΦΕ - BROWN		



STOCK No :		ΚΩΔΙΚΟΣ : ART. No :	415-15-800-11
ΠΕΡΙΓΡΑΦΗ: DESCRIPTION:	ΒΑΣΙΚΟ ΣΕΤ ΜΗΧΑΝΙΣΜΟΥ - ΠΛΕΥΡΑ ΜΕΝΤΕΣΕ JET AK8 HINGE SIDE		
ΥΛΙΚΟ: MATERIAL:	ΑΛΟΥΜΙΝΙΟ - ΖΑΜΑΚ ALUMINIUM - ZAMAK	ΣΥΣΚΕΥΑΣΙΑ: PACKAGE:	10
ΧΡΩΜΑ: COLOR:	ΑΣΗΜΙ ΑΝΟΔ. / SILVER ANOD., 415-15-800-00 ΑΒΑΦΟ / MILL FINISH, 415-15-800-02 ΛΕΥΚΟ / WHITE, 415-15-800-03 ΜΑΥΡΟ / BLACK		



STOCK No :		ΚΩΔΙΚΟΣ : ART. No :	415-16-595-00
ΠΕΡΙΓΡΑΦΗ: DESCRIPTION:	ΠΡΟΣΘΕΤΟ ΕΞΑΡΤΗΜΑ ΓΙΑ ΜΕΝΤΕΣΕ 130 kg ADDITIONAL PARTS FOR HINGE 130 kg		
ΥΛΙΚΟ: MATERIAL:	ΙΝΟΧ	ΣΥΣΚΕΥΑΣΙΑ: PACKAGE:	
ΧΡΩΜΑ: COLOR:	ΑΣΗΜΙ SILVER	ΔΙΑΣΤΑΣΗ: DIMENSION:	

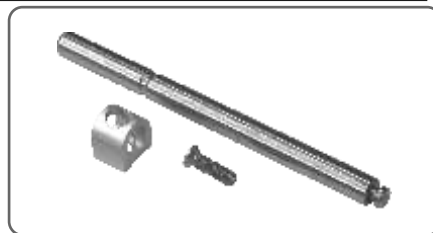

STOCK No :		ΚΩΔΙΚΟΣ : ART. No :	415-15-801-00
ΠΕΡΙΓΡΑΦΗ: DESCRIPTION:	ΒΑΣΙΚΟ ΣΕΤ ΜΗΧΑΝΙΣΜΟΥ - ΠΛΕΥΡΑ ΧΕΡΟΥΛΙΟΥ JET AK8 LOCKING PARTS FOR GEARED HANDLE		
ΥΛΙΚΟ: MATERIAL:	ΖΑΜΑΚ	ΣΥΣΚΕΥΑΣΙΑ: PACKAGE:	
ΧΡΩΜΑ: COLOR:		ΔΙΑΣΤΑΣΗ: DIMENSION:	





ΚΩΔΙΚΟΣ : 415-95-901-00 **STOCK No :**
ART. No :
ΠΕΡΙΓΡΑΦΗ: ΠΛΑΚΑΚΙ ΚΛΕΙΔΩΜΑΤΟΣ ΜΗ ΡΥΘΜΙΖΟΜΕΝΟ
DESCRIPTION: LOCKING PLATE
ΥΛΙΚΟ: ZAMAK **ΣΥΣΚΕΥΑΣΙΑ:**
MATERIAL: **PACKAGE:**
ΧΡΩΜΑ: **ΔΙΑΣΤΑΣΗ:**
COLOR: **DIMENSION:**

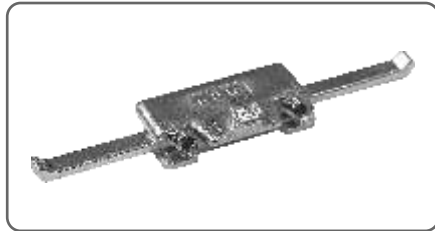

ΚΩΔΙΚΟΣ : 415-96-401-00 **STOCK No :**
ART. No :
ΠΕΡΙΓΡΑΦΗ: ΠΛΑΚΑΚΙ ΑΝΑΚΛΙΣΗΣ
DESCRIPTION: TILT-LOCKING PLATE
ΥΛΙΚΟ: ZAMAK **ΣΥΣΚΕΥΑΣΙΑ:**
MATERIAL: **PACKAGE:**
ΧΡΩΜΑ: **ΔΙΑΣΤΑΣΗ:**
COLOR: **DIMENSION:**

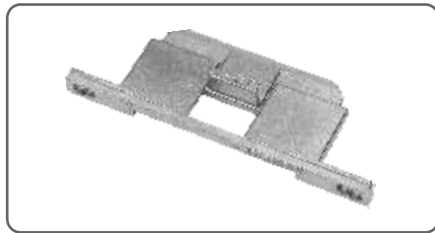

ΚΩΔΙΚΟΣ : 415-63-654-00 **STOCK No :**
ART. No :
ΠΕΡΙΓΡΑΦΗ: ΑΣΦΑΛΕΙΑ ΧΕΡΟΥΛΙΟΥ
DESCRIPTION: WRONG OPERATION SAFETY DEVICE
ΥΛΙΚΟ: ZAMAK **ΣΥΣΚΕΥΑΣΙΑ:**
MATERIAL: **PACKAGE:**
ΧΡΩΜΑ: **ΔΙΑΣΤΑΣΗ:**
COLOR: **DIMENSION:**

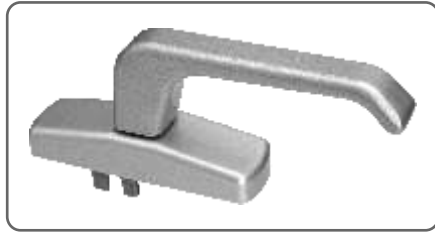

ΚΩΔΙΚΟΣ : 415-46-551-11 **STOCK No :**
ART. No :
ΠΕΡΙΓΡΑΦΗ: ΧΕΙΡΟΛΑΒΗ SPACIO
DESCRIPTION: HANDLE SPACIO
ΥΛΙΚΟ: ΑΛΟΥΜΙΝΙΟ **ΣΥΣΚΕΥΑΣΙΑ:**
MATERIAL: ALUMINIUM **PACKAGE:**
ΧΡΩΜΑ: ΑΣΗΜΙ ΑΝΟΔ. / SILVER ANOD., 415-46-551-00 ΑΒΑΦΟ / MILL FINISH,
COLOR: 415-46-551-02 ΛΕΥΚΟ / WHITE, 415-46-551-03 ΜΑΥΡΟ / BLACK



ΚΩΔΙΚΟΣ : 415-17-527-00 **STOCK No :**
ART. No :
ΠΕΡΙΓΡΑΦΗ: ΜΕΤΑΦΟΡΕΑΣ ΚΙΝΗΣΗΣ ΛΑΒΗΣ ΑΚ - 8 ΔΙΦΥΛΛΟΥ D/F ΓΙΑ ΑΠΛΟ ΑΝΟΙΓΟΜΕΝΟ
DESCRIPTION: DRIVER FOR D/F
ΥΛΙΚΟ: ZAMAK **ΣΥΣΚΕΥΑΣΙΑ:**
MATERIAL: **PACKAGE:**
ΧΡΩΜΑ: **ΔΙΑΣΤΑΣΗ:**
COLOR: **DIMENSION:**



ΚΩΔΙΚΟΣ : 415-15-805-00 **STOCK No :**
ART. No :
ΠΕΡΙΓΡΑΦΗ: ΨΑΛΙΔΙ No 1
DESCRIPTION: JET AK STAY ARM 30
ΥΛΙΚΟ: INOX - ZAMAK **ΣΥΣΚΕΥΑΣΙΑ:** 10
MATERIAL: **PACKAGE:**
ΧΡΩΜΑ: **ΔΙΑΣΤΑΣΗ:** 355 - 600 mm
COLOR: **DIMENSION:**

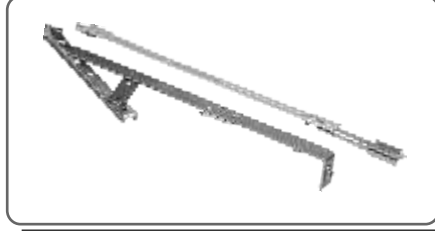

ΚΩΔΙΚΟΣ : 415-15-806-00 **STOCK No :**
ART. No :
ΠΕΡΙΓΡΑΦΗ: ΓΩΝΙΑ ΕΠΙΠΕΔΟΤΗΤΑΣ
DESCRIPTION: ALIGNMENT CORNER
ΥΛΙΚΟ: INOX - ZAMAK **ΣΥΣΚΕΥΑΣΙΑ:** 10
MATERIAL: **PACKAGE:**
ΧΡΩΜΑ: **ΔΙΑΣΤΑΣΗ:** 601 - 1000 mm
COLOR: **DIMENSION:**

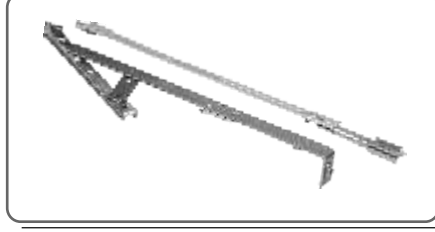

ΚΩΔΙΚΟΣ : 415-15-807-00 **STOCK No :**
ART. No :
ΠΕΡΙΓΡΑΦΗ: ΓΩΝΙΑ ΕΠΙΠΕΔΟΤΗΤΑΣ
DESCRIPTION: ALIGNMENT CORNER
ΥΛΙΚΟ: INOX - ZAMAK **ΣΥΣΚΕΥΑΣΙΑ:** 10
MATERIAL: **PACKAGE:**
ΧΡΩΜΑ: **ΔΙΑΣΤΑΣΗ:** 1001 - 1400 mm
COLOR: **DIMENSION:**

STOCK No :	ΚΩΔΙΚΟΣ : ART. No :	415-12-964-00
ΠΕΡΙΓΡΑΦΗ: DESCRIPTION:	ΨΑΛΙΔΙ ΔΕΥΤΕΡΟ ΑΚ - ΙΚ / ΑΚ - 8 ADDITIONAL STAY ARM	
ΥΛΙΚΟ: MATERIAL:	INOX - ZAMAK	ΣΥΣΚΕΥΑΣΙΑ: PACKAGE:
ΧΡΩΜΑ: COLOR:	ΔΙΑΣΤΑΣΗ: DIMENSION:	



STOCK No :	ΚΩΔΙΚΟΣ : ART. No :	415-63-106-00
ΠΕΡΙΓΡΑΦΗ: DESCRIPTION:	ΤΥΦΛΟ ΨΑΛΙΔΙ ΑΚ - 8 ΡΥΘΜΙΖΟΜΕΝΟ SIDE HUNG SASH HINGE ADJUSTABLE	
ΥΛΙΚΟ: MATERIAL:	INOX - ZAMAK	ΣΥΣΚΕΥΑΣΙΑ: PACKAGE:
ΧΡΩΜΑ: COLOR:	ΔΙΑΣΤΑΣΗ: DIMENSION:	



STOCK No :	ΚΩΔΙΚΟΣ : ART. No :	415-15-808-00
ΠΕΡΙΓΡΑΦΗ: DESCRIPTION:	ΒΑΣΙΚΟ ΚΟΥΤΙ ΠΙΣΩ ΕΝΙΣΧΥΣΗΣ BAG OF MIDDLE LOCK	
ΥΛΙΚΟ: MATERIAL:	ZAMAK	ΣΥΣΚΕΥΑΣΙΑ: PACKAGE:
ΧΡΩΜΑ: COLOR:	ΔΙΑΣΤΑΣΗ: DIMENSION:	

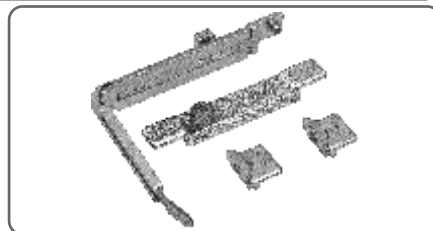

STOCK No :	ΚΩΔΙΚΟΣ : ART. No :	415-62-390-00
ΠΕΡΙΓΡΑΦΗ: DESCRIPTION:	ΕΝΙΣΧΥΣΗ ALU LOCKING PIN ELEMENT	
ΥΛΙΚΟ: MATERIAL:	ZAMAK	ΣΥΣΚΕΥΑΣΙΑ: PACKAGE:
ΧΡΩΜΑ: COLOR:	ΔΙΑΣΤΑΣΗ: DIMENSION:	

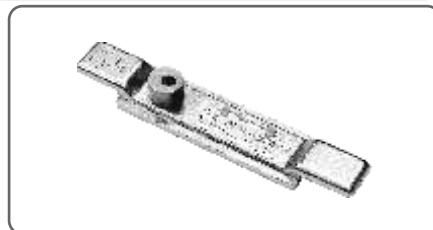

STOCK No :	ΚΩΔΙΚΟΣ : ART. No :	415-62-290-00
ΠΕΡΙΓΡΑΦΗ: DESCRIPTION:	ΓΩΝΙΑ ΚΙΝΗΣΗΣ ΑΚ80 GU 978 CORNER TRANSMISSION	
ΥΛΙΚΟ: MATERIAL:	ZAMAK	ΣΥΣΚΕΥΑΣΙΑ: PACKAGE:
ΧΡΩΜΑ: COLOR:	ΔΙΑΣΤΑΣΗ: DIMENSION:	

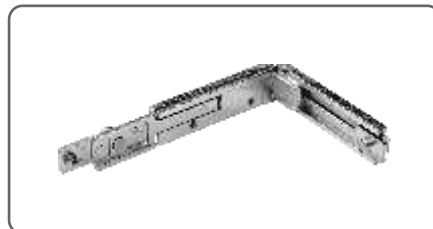

STOCK No :	ΚΩΔΙΚΟΣ : ART. No :	416-72-250-02
ΠΕΡΙΓΡΑΦΗ: DESCRIPTION:	ΣΠΑΝΙΟΛΕΤΑ ΜΕ ΚΑΡΕ HANDLE WITH SQUARE PIN	
ΥΛΙΚΟ: MATERIAL:	ΑΛΟΥΜΙΝΙΟ ALUMINIUM	ΣΥΣΚΕΥΑΣΙΑ: PACKAGE:
ΧΡΩΜΑ: COLOR:	ΛΕΥΚΟ / WHITE, 416-72-250-06 ΚΑΦΕ / BROWN, 416-72-250-11 ΑΣΗΜΙ / SILVER	ΔΙΑΣΤΑΣΗ: DIMENSION:



STOCK No :	ΚΩΔΙΚΟΣ : ART. No :	415-15-811-00
ΠΕΡΙΓΡΑΦΗ: DESCRIPTION:	ΒΑΣΙΚΟ ΚΟΥΤΙ ΛΑΒΗΣ ΣΠΑΝΙΟΛΕΤΑΣ ΜΕ ΚΑΡΡΕ JET AK 8 LOCKING PARTS WITH MILL- IN GEAR	
ΥΛΙΚΟ: MATERIAL:	ZAMAK	ΣΥΣΚΕΥΑΣΙΑ: PACKAGE:
ΧΡΩΜΑ: COLOR:	ΔΙΑΣΤΑΣΗ: DIMENSION:	

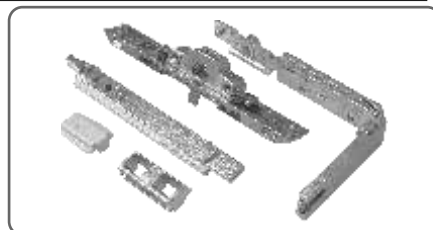

STOCK No :	ΚΩΔΙΚΟΣ : ART. No :	415-45-929-00
ΠΕΡΙΓΡΑΦΗ: DESCRIPTION:	ΒΑΣΙΚΟ ΚΟΥΤΙ ΚΡΥΦΟΥ ΣΥΡΤΗ ALLEN BAG OF INACTIVE SASH GEAR	
ΥΛΙΚΟ: MATERIAL:	ZAMAK	ΣΥΣΚΕΥΑΣΙΑ: PACKAGE:
ΧΡΩΜΑ: COLOR:	ΔΙΑΣΤΑΣΗ: DIMENSION:	

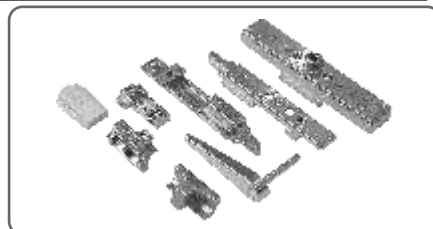

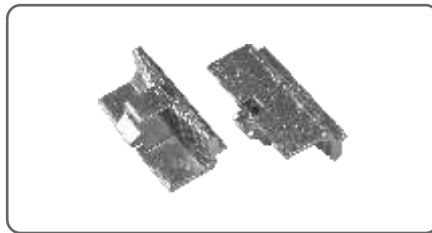

ΚΩΔΙΚΟΣ : ART. No :	415-45-939-00	STOCK No :
ΠΕΡΙΓΡΑΦΗ: DESCRIPTION:	ΠΛΑΚΑΚΙ ΚΛΕΙΔΩΜΑΤΟΣ ΣΥΡΤΗ ΡΥΘΜΙΖΟΜΕΝΟ (ΣΕΤ) SHOOT BOLT LOCKING PLATE ADJUSTABLE (SET)	
ΥΛΙΚΟ: MATERIAL:	ZAMAK	ΣΥΣΚΕΥΑΣΙΑ: PACKAGE:
ΧΡΩΜΑ: COLOR:		ΔΙΑΣΤΑΣΗ: DIMENSION:

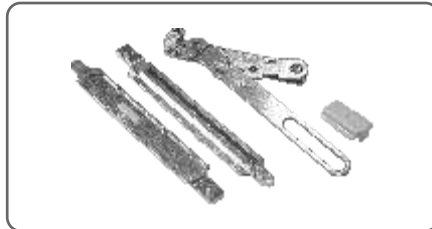

ΚΩΔΙΚΟΣ : ART. No :	415-15-803-00	STOCK No :
ΠΕΡΙΓΡΑΦΗ: DESCRIPTION:	ΜΟΝΟΚΟΜΜΑΤΟΣ ΣΥΡΤΗΣ ΕΞΩΤΕΡΙΚΟΣ REBATE SHOOT BOLT	
ΥΛΙΚΟ: MATERIAL:	ZAMAK	ΣΥΣΚΕΥΑΣΙΑ: PACKAGE:
ΧΡΩΜΑ: COLOR:		ΔΙΑΣΤΑΣΗ: DIMENSION:



ΚΩΔΙΚΟΣ : ART. No :	416-80-009-00	STOCK No :
ΠΕΡΙΓΡΑΦΗ: DESCRIPTION:	ΚΑΛΥΜΑ ΛΑΒΗΣ ΜΟΝΟΚΟΜΜΑΤΟΥ ΣΥΡΤΗ PROTECTIVE CAP FOR REBATE LEVER	
ΥΛΙΚΟ: MATERIAL:	ΠΛΑΣΤΙΚΟ PLASTIC	ΣΥΣΚΕΥΑΣΙΑ: PACKAGE:
ΧΡΩΜΑ: COLOR:	ΚΟΚΚΙΝΟ RED	ΔΙΑΣΤΑΣΗ: DIMENSION:



ΚΩΔΙΚΟΣ : ART. No :	415-94-160-00	STOCK No :
ΠΕΡΙΓΡΑΦΗ: DESCRIPTION:	ΝΤΙΖΑ ΣΥΝΔΕΣΗΣ ΜΟΝΟΚΟΜΜΑΤΟΥ ΣΥΡΤΗ ΕΞΩΤ. PUSH ROD FOR REBATE SHOOT BOLT	
ΥΛΙΚΟ: MATERIAL:	ΑΛΟΥΜΙΝΙΟ ALUMINIUM	ΣΥΣΚΕΥΑΣΙΑ: PACKAGE:
ΧΡΩΜΑ: COLOR:		ΔΙΑΣΤΑΣΗ: DIMENSION: 1600 mm



ΚΩΔΙΚΟΣ : ART. No :	415-63-961-00	STOCK No :
ΠΕΡΙΓΡΑΦΗ: DESCRIPTION:	ΠΛΑΚΑΚΙ ΚΛΕΙΔΩΜΑΤΟΣ ΣΥΡΤΗ ΡΥΘΜΙΖΟΜ. SHOOT BOLT LOCKING PLATE ADJUSTABLE	
ΥΛΙΚΟ: MATERIAL:	ZAMAK	ΣΥΣΚΕΥΑΣΙΑ: PACKAGE:
ΧΡΩΜΑ: COLOR:		ΔΙΑΣΤΑΣΗ: DIMENSION:



ΚΩΔΙΚΟΣ : ART. No :	415-15-818-00	STOCK No :
ΠΕΡΙΓΡΑΦΗ: DESCRIPTION:	ΣΥΡΤΕΣ ΕΞΩΤΕΡΙΚΟΙ D/K SHOOT RODS FOR INACTIVE SASH D/K	
ΥΛΙΚΟ: MATERIAL:	ΑΛΟΥΜΙΝΙΟ ALUMINIUM	ΣΥΣΚΕΥΑΣΙΑ: PACKAGE:
ΧΡΩΜΑ: COLOR:		ΔΙΑΣΤΑΣΗ: DIMENSION: 400 mm & 125 mm

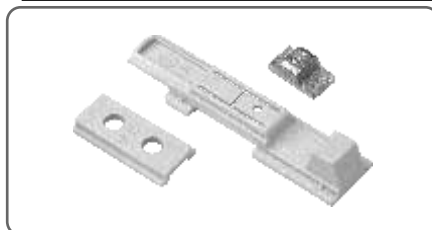

ΚΩΔΙΚΟΣ : ART. No :	415-15-816-00	STOCK No :
ΠΕΡΙΓΡΑΦΗ: DESCRIPTION:	ΧΕΙΡΙΣΤΗΡΙΟ ΕΞΩΤΕΡΙΚΩΝ ΣΥΡΤΩΝ D/K SLIDE FOR SHOOT BOLT D/K	
ΥΛΙΚΟ: MATERIAL:	ΠΛΑΣΤΙΚΟ PLASTIC	ΣΥΣΚΕΥΑΣΙΑ: PACKAGE:
ΧΡΩΜΑ: COLOR:		ΔΙΑΣΤΑΣΗ: DIMENSION:

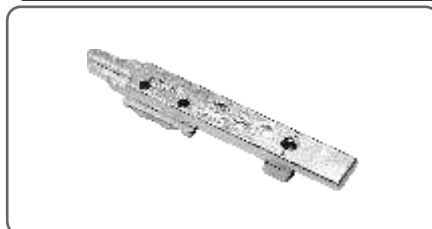

ΚΩΔΙΚΟΣ : ART. No :	415-17-500-00	STOCK No :
ΠΕΡΙΓΡΑΦΗ: DESCRIPTION:	ΣΥΡΤΗΣ ΜΕΤΑΦΟΡΕΑ ΛΑΒΗΣ ΓΙΑ ΑΝΟΙΓΟΜΕΝΟ SHOOT BOLT	
ΥΛΙΚΟ: MATERIAL:	ZAMAK	ΣΥΣΚΕΥΑΣΙΑ: PACKAGE:
ΧΡΩΜΑ: COLOR:		ΔΙΑΣΤΑΣΗ: DIMENSION:

STOCK No :	ΚΩΔΙΚΟΣ : ART. No :	415-13-529-00
ΠΕΡΙΓΡΑΦΗ: DESCRIPTION:	ΠΙΣΩ ΚΛΕΙΣΙΜΟ ΡΥΘΜΙΖΟΜΕΝΟ 14/18 MIDDLE BEARING 14/18	
ΥΛΙΚΟ: MATERIAL:	ΖΑΜΑΚ	ΣΥΣΚΕΥΑΣΙΑ: PACKAGE:
ΧΡΩΜΑ: COLOR:	ΔΙΑΣΤΑΣΗ: DIMENSION:	

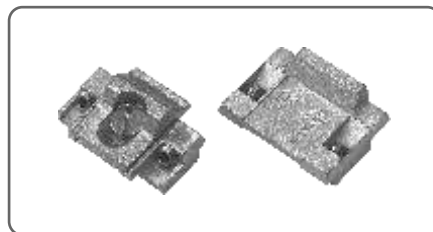

STOCK No :	ΚΩΔΙΚΟΣ : ART. No :	415-15-820-11
ΠΕΡΙΓΡΑΦΗ: DESCRIPTION:	ΔΙΠΛΟΣ ΜΕΝΤΕΣΕΣ ΑΝΟΙΓΟΜΕΝΟΥ ΦΥΛΛΟΥ DOUBLE HINGE	
ΥΛΙΚΟ: MATERIAL:	ΑΛΟΥΜΙΝΙΟ ALUMINIUM	ΔΙΑΣΤΑΣΗ: 93 mm DIMENSION:
ΧΡΩΜΑ: COLOR:	ΑΣΗΜΙ ΑΝΟΔ. / SILVER ANOD., 415-15-820-00 ΑΒΑΦΟ / MILL FINISH, 415-15-820-02 ΛΕΥΚΟ / WHITE, 415-15-820-03 ΜΑΥΡΟ /	



STOCK No :	ΚΩΔΙΚΟΣ : ART. No :	415-15-817-00
ΠΕΡΙΓΡΑΦΗ: DESCRIPTION:	ΣΥΡΤΗΣ ΕΞΩΤΕΡΙΚΟΣ D/F SHOOT BOLT D/F	
ΥΛΙΚΟ: MATERIAL:	ΠΛΑΣΤΙΚΟ PLASTIC	ΣΥΣΚΕΥΑΣΙΑ: PACKAGE:
ΧΡΩΜΑ: COLOR:	ΔΙΑΣΤΑΣΗ: DIMENSION:	

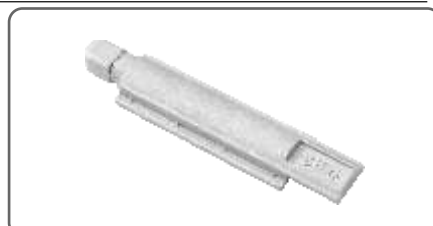

STOCK No :	ΚΩΔΙΚΟΣ : ART. No :	415-15-819-00
ΠΕΡΙΓΡΑΦΗ: DESCRIPTION:	ΑΝΤΙΚΡΙΣΜΑ ΚΛΕΙΔΑΡΙΑΣ ΣΥΡΤΗ ΕΞΩΤΕΡΙΚΟ D/F BOLT LOCKING PLATE D/F	
ΥΛΙΚΟ: MATERIAL:	ΠΛΑΣΤΙΚΟ PLASTIC	ΣΥΣΚΕΥΑΣΙΑ: PACKAGE:
ΧΡΩΜΑ: COLOR:	ΔΙΑΣΤΑΣΗ: DIMENSION:	



STOCK No :	ΚΩΔΙΚΟΣ : ART. No :	415-96-200-00
ΠΕΡΙΓΡΑΦΗ: DESCRIPTION:	ΣΥΓΚΡΑΤΗΤΗΣ ΦΥΛΛΟΥ BAG OF DOOR LATCH	
ΥΛΙΚΟ: MATERIAL:	ΖΑΜΑΚ	ΣΥΣΚΕΥΑΣΙΑ: PACKAGE:
ΧΡΩΜΑ: COLOR:	ΔΙΑΣΤΑΣΗ: DIMENSION:	

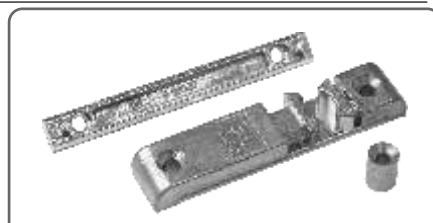

STOCK No :	ΚΩΔΙΚΟΣ : ART. No :	380-50-113-02
ΠΕΡΙΓΡΑΦΗ: DESCRIPTION:	ΣΠΑΝΙΟΛΕΤΑ ΜΗΧΑΝΙΣΜΟΥ HANDLE FOR WINDOWS	
ΥΛΙΚΟ: MATERIAL:	ΑΛΟΥΜΙΝΙΟ ALUMINIUM	ΣΥΣΚΕΥΑΣΙΑ: 10 - 40 PACKAGE:
ΧΡΩΜΑ: COLOR:	ΛΕΥΚΟ / WHITE 380-50-114-03 ΜΑΥΡΟ / BLACK	ΔΙΑΣΤΑΣΗ: DIMENSION:



STOCK No :	ΚΩΔΙΚΟΣ : ART. No :	390-50-020-00
ΠΕΡΙΓΡΑΦΗ: DESCRIPTION:	ΒΑΣΙΚΟ ΣΕΤ ΜΗΧΑΝΙΣΜΟΥ - ΠΛΕΥΡΑ ΜΕΝΤΕΣΕ BASIC SET TILT AND TURN	
ΥΛΙΚΟ: MATERIAL:	ΣΥΣΚΕΥΑΣΙΑ: 10 - 60 PACKAGE:	
ΧΡΩΜΑ: COLOR:	ΔΙΑΣΤΑΣΗ: DIMENSION:	



STOCK No :	ΚΩΔΙΚΟΣ : ART. No :	300-00-460-00
ΠΕΡΙΓΡΑΦΗ: DESCRIPTION:	ΨΑΛΙΔΙ ΜΗΧΑΝΙΣΜΟΥ No 2 SCISSOR ARM No 2	
ΥΛΙΚΟ: MATERIAL:	ΣΥΣΚΕΥΑΣΙΑ: 5 - 40 PACKAGE:	
ΧΡΩΜΑ: COLOR:	ΔΙΑΣΤΑΣΗ: 460 mm DIMENSION:	

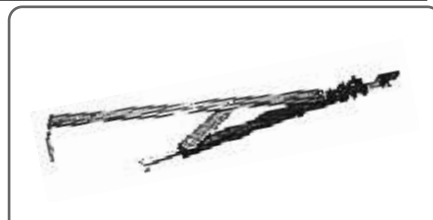

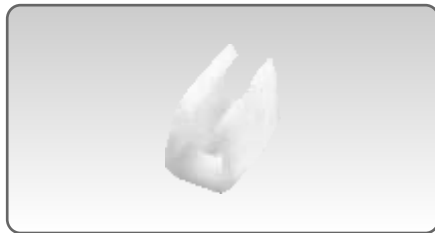

ΚΩΔΙΚΟΣ : 425-00-878-00 **STOCK No :**
ART. No :
ΠΕΡΙΓΡΑΦΗ: ΟΔΗΓΟΣ ΝΤΙΖΑΣ ΦΕΓΓΙΤΗ
DESCRIPTION: DRIVER FOR HOPPER
ΥΛΙΚΟ: PVC **ΣΥΣΚΕΥΑΣΙΑ:** 10
MATERIAL: **PACKAGE:**
ΧΡΩΜΑ: **ΔΙΑΣΤΑΣΗ:**
COLOR: **DIMENSION:**

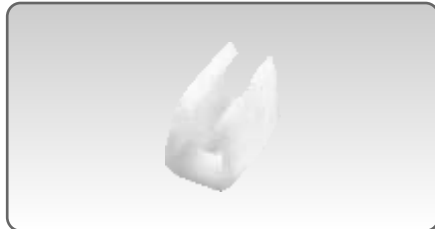

ΚΩΔΙΚΟΣ : 425-10-878-00 **STOCK No :**
ART. No :
ΠΕΡΙΓΡΑΦΗ: ΠΛΑΣΤΙΚΟΣ ΟΔΗΓΟΣ ΝΤΙΖΑΣ Φ8
DESCRIPTION: PLASTIC ROD GUIDE
ΥΛΙΚΟ: PVC **ΣΥΣΚΕΥΑΣΙΑ:** 10
MATERIAL: **PACKAGE:**
ΧΡΩΜΑ: **ΔΙΑΣΤΑΣΗ:**
COLOR: **DIMENSION:**



ΚΩΔΙΚΟΣ : 425-06-555-00 **STOCK No :**
ART. No :
ΠΕΡΙΓΡΑΦΗ: ΝΤΙΖΑ ΦΕΓΓΙΤΗ
DESCRIPTION: ROD FOR HOPPER
ΥΛΙΚΟ: **ΣΥΣΚΕΥΑΣΙΑ:**
MATERIAL: **PACKAGE:**
ΧΡΩΜΑ: **ΔΙΑΣΤΑΣΗ:**
COLOR: **DIMENSION:**



ΚΩΔΙΚΟΣ : 425-30-401-00 **STOCK No :**
ART. No :
ΠΕΡΙΓΡΑΦΗ: ΚΑΠΑΚΙ ΝΤΙΖΑΣ ΦΕΓΓΙΤΗ
DESCRIPTION: COVER FOR TRANSOM ROD
ΥΛΙΚΟ: **ΣΥΣΚΕΥΑΣΙΑ:**
MATERIAL: **PACKAGE:**
ΧΡΩΜΑ: ΑΣΗΜΙ **ΔΙΑΣΤΑΣΗ:**
COLOR: SILVER **DIMENSION:**

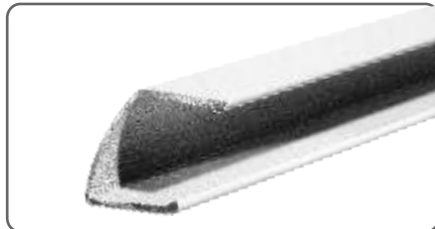

ΚΩΔΙΚΟΣ : 425-30-403-02 **STOCK No :**
ART. No :
ΠΕΡΙΓΡΑΦΗ: ΠΡΟΦΙΛ ΚΑΛΥΜΑ ΝΤΙΖΑΣ
DESCRIPTION: COVER FOR TRANSOM ROD
ΥΛΙΚΟ: **ΣΥΣΚΕΥΑΣΙΑ:**
MATERIAL: **PACKAGE:**
ΧΡΩΜΑ: ΛΕΥΚΟ **ΔΙΑΣΤΑΣΗ:**
COLOR: WHITE **DIMENSION:**

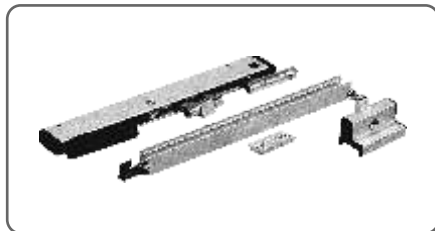

ΚΩΔΙΚΟΣ : 425-30-373-00 **STOCK No :**
ART. No :
ΠΕΡΙΓΡΑΦΗ: ΨΑΛΙΔΙ & ΣΤΗΡΙΓΜΑ ΦΥΛΛΟΥ ΦΕΓΓΙΤΗ
DESCRIPTION: SCISSOR & CASEMENT BRACKET
ΥΛΙΚΟ: **ΣΥΣΚΕΥΑΣΙΑ:** 1
MATERIAL: **PACKAGE:**
ΧΡΩΜΑ: ΑΣΗΜΙ / SILVER **ΔΙΑΣΤΑΣΗ:**
COLOR: 425-30-375-02 ΛΕΥΚΟ / WHITE **DIMENSION:**



ΚΩΔΙΚΟΣ : 425-30-611-00 **STOCK No :**
ART. No :
ΠΕΡΙΓΡΑΦΗ: ΧΕΡΟΥΛΙ ΦΕΓΓΙΤΗ ΜΕ ΓΩΝΙΑ
DESCRIPTION: HANDLE FOR HOPPER
ΥΛΙΚΟ: **ΣΥΣΚΕΥΑΣΙΑ:**
MATERIAL: **PACKAGE:**
ΧΡΩΜΑ: ΑΣΗΜΙ / SILVER **ΔΙΑΣΤΑΣΗ:**
COLOR: 425-30-613-02 ΛΕΥΚΟ / WHITE **DIMENSION:**



ΚΩΔΙΚΟΣ : 426-09-381-00 **STOCK No :**
ART. No :
ΠΕΡΙΓΡΑΦΗ: ΦΩΛΙΑ ΠΑΝΤΖΟΥΡΙΟΥ ΧΑΜΗΛΗ ΔΑΠΕΔΟΥ
DESCRIPTION: LOCK POINT FOR 9395
ΥΛΙΚΟ: ΠΟΛΥΑΜΙΔΙΟ **ΣΥΣΚΕΥΑΣΙΑ:**
MATERIAL: POLYAMIDE **PACKAGE:**
ΧΡΩΜΑ: ΜΑΥΡΟ **ΔΙΑΣΤΑΣΗ:**
COLOR: BLACK **DIMENSION:**

STOCK No : **ΚΩΔΙΚΟΣ : 426-09-395-00**
ART. No :

ΠΕΡΙΓΡΑΦΗ: **ΑΝΤΙΚΡΙΣΜΑ ΠΑΝΤΖΟΥΡΙΟΥ**
DESCRIPTION: **LOCK POINT**

ΥΛΙΚΟ: ΣΥΣΚΕΥΑΣΙΑ:
MATERIAL: PACKAGE:

ΧΡΩΜΑ: ΔΙΑΣΤΑΣΗ:
COLOR: DIMENSION:



STOCK No : **ΚΩΔΙΚΟΣ : 390-50-110-00**
ART. No :

ΠΕΡΙΓΡΑΦΗ: **ΣΕΤ ΓΙΑ ΕΞΤΡΑ ΚΛΕΙΣΙΜΟ**
DESCRIPTION: **SET EXTRA LOCK POINT**

ΥΛΙΚΟ: ΣΥΣΚΕΥΑΣΙΑ: 10 - 180
MATERIAL: PACKAGE:

ΧΡΩΜΑ: ΔΙΑΣΤΑΣΗ:
COLOR: DIMENSION:

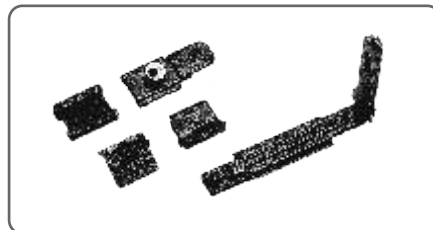

STOCK No : **ΚΩΔΙΚΟΣ : 390-50-101-00**
ART. No :

ΠΕΡΙΓΡΑΦΗ: **ΚΡΥΦΟ ΠΙΣΩ ΚΛΕΙΣΙΜΑΤΟΣ, ΡΥΘΜΙΣΜ.**
DESCRIPTION: **LOCK POINT**

ΥΛΙΚΟ: ΣΥΣΚΕΥΑΣΙΑ: 25
MATERIAL: PACKAGE:

ΧΡΩΜΑ: ΔΙΑΣΤΑΣΗ:
COLOR: DIMENSION:

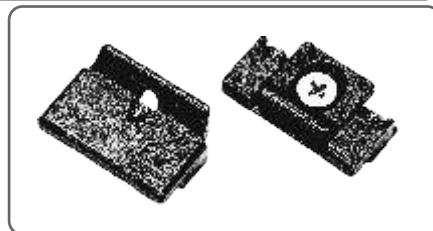

STOCK No : **ΚΩΔΙΚΟΣ : 350-50-401-02**
ART. No :

ΠΕΡΙΓΡΑΦΗ: **ΣΕΤ ΜΕΝΤΕΣΕ ΜΗΧΑΝΙΣΜΟΥ 70 Kg**
DESCRIPTION: **HINGE**

ΥΛΙΚΟ: ΑΛΟΥΜΙΝΙΟ ΣΥΣΚΕΥΑΣΙΑ: 5 - 40
MATERIAL: ALUMINIUM PACKAGE:

ΧΡΩΜΑ: ΛΕΥΚΟ / WHITE, 350-05-402-03 ΜΑΥΡΟ / ΔΙΑΣΤΑΣΗ:
COLOR: BLACK, DIMENSION:



STOCK No : **ΚΩΔΙΚΟΣ : 474-22-001-00**
ART. No :

ΠΕΡΙΓΡΑΦΗ: **ΣΥΡΤΗΣ ΔΙΦΥΛΛΟΥ ΤΥΠΟΥ ROTTO**
DESCRIPTION: **DEAD BOLT LATCH**

ΥΛΙΚΟ: ΣΥΣΚΕΥΑΣΙΑ: 50
MATERIAL: PACKAGE:

ΧΡΩΜΑ: ΔΙΑΣΤΑΣΗ:
COLOR: DIMENSION:

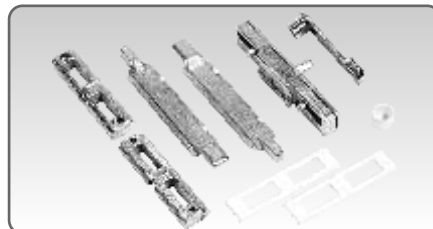

STOCK No : **ΚΩΔΙΚΟΣ : 480-00-094-00**
ART. No :

ΠΕΡΙΓΡΑΦΗ: **ΚΙΤ ΣΠΑΝΙΟΛΕΤΑΣ ΑΝΟΙΓΟΜΕΝΟΥ**
DESCRIPTION: **CAMERA HANDLE FOR WINDOWS**

ΥΛΙΚΟ: ΣΥΣΚΕΥΑΣΙΑ: 80
MATERIAL: PACKAGE:

ΧΡΩΜΑ: ΜΑΥΡΟ ΔΙΑΣΤΑΣΗ:
COLOR: BLACK DIMENSION:



STOCK No : **ΚΩΔΙΚΟΣ : 390-50-330-00**
ART. No :

ΠΕΡΙΓΡΑΦΗ: **ΦΩΛΙΑ ΧΥΤΗ**
DESCRIPTION: **LOCK POINT**

ΥΛΙΚΟ: ΑΤΣΑΛΙ ΣΥΣΚΕΥΑΣΙΑ: 25
MATERIAL: STEEL PACKAGE:

ΧΡΩΜΑ: ΔΙΑΣΤΑΣΗ:
COLOR: DIMENSION:



STOCK No : **ΚΩΔΙΚΟΣ : 421-14-049-00**
ART. No :

ΠΕΡΙΓΡΑΦΗ: **ΨΑΛΙΔΙ ΜΗΧΑΝΙΣΜΟΥ ΜΙΚΡΟ**
DESCRIPTION: **SCISSOR ARM**

ΥΛΙΚΟ: ΣΥΣΚΕΥΑΣΙΑ: 1 - 50
MATERIAL: PACKAGE:

ΧΡΩΜΑ: ΔΙΑΣΤΑΣΗ:
COLOR: DIMENSION:

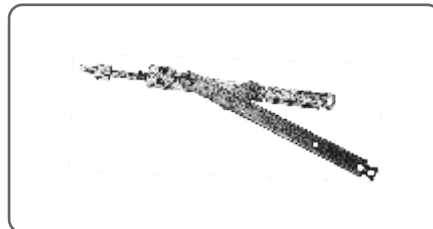



ΚΩΔΙΚΟΣ : 455-50-202-03 **STOCK No :**

ΠΕΡΙΓΡΑΦΗ: ΧΕΡΟΥΛΙ ΕΙΣΟΔΟΥ ΔΙΠΛΟ GLOBO
DESCRIPTION: PAIR OF DOOR HANDLES

ΥΛΙΚΟ: ΣΥΣΚΕΥΑΣΙΑ: 1 - 10
MATERIAL: PACKAGE:

ΧΡΩΜΑ: ΜΑΥΡΟ / BLACK **ΔΙΑΣΤΑΣΗ:**
COLOR: 455-50-221-02 ΛΕΥΚΟ / WHITE **DIMENSION:**

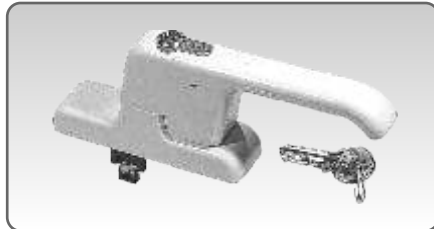

ΚΩΔΙΚΟΣ : 380-00-702-02 **STOCK No :**

ΠΕΡΙΓΡΑΦΗ: ΣΠΑΝΙΟΛΕΤΑ ΜΗΧΑΝΙΣΜΟΥ EURO ΜΕ ΚΛΕΙΔΙ
DESCRIPTION: HANDLE EURO WITH KEY

ΥΛΙΚΟ: ΣΥΣΚΕΥΑΣΙΑ: 5
MATERIAL: PACKAGE:

ΧΡΩΜΑ: ΛΕΥΚΟ / WHITE **ΔΙΑΣΤΑΣΗ:**
COLOR: 380-00-702-03 ΜΑΥΡΟ / BLACK **DIMENSION:**

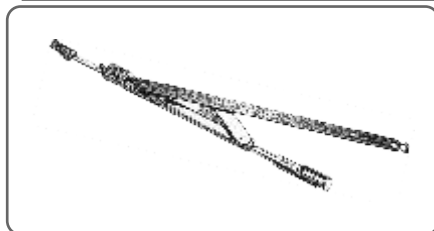

ΚΩΔΙΚΟΣ : 421-14-050-00 **STOCK No :**

ΠΕΡΙΓΡΑΦΗ: ΨΑΛΙΔΙ ΜΗΧΑΝΙΣΜΟΥ ΜΕΓΑΛΟ
DESCRIPTION: SCISSOR ARM

ΥΛΙΚΟ: ΣΥΣΚΕΥΑΣΙΑ: 1 - 50
MATERIAL: PACKAGE:

ΧΡΩΜΑ: **ΔΙΑΣΤΑΣΗ:**
COLOR: **DIMENSION:**



ΚΩΔΙΚΟΣ : 421-01-481-00 **STOCK No :**

ΠΕΡΙΓΡΑΦΗ: ΒΑΣΙΚΟ ΣΕΤ ΜΟΝΟΦΥΛΛΟΥ
DESCRIPTION: BASIC SET TILT AND TURN

ΥΛΙΚΟ: ΣΥΣΚΕΥΑΣΙΑ: 1 - 50
MATERIAL: PACKAGE:

ΧΡΩΜΑ: **ΔΙΑΣΤΑΣΗ:**
COLOR: **DIMENSION:**

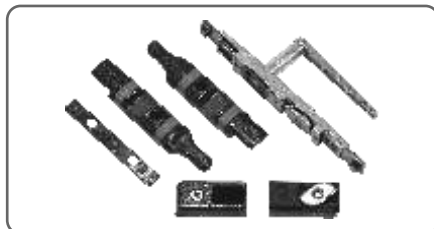

ΚΩΔΙΚΟΣ : 474-01-502-00 **STOCK No :**

ΠΕΡΙΓΡΑΦΗ: ΣΥΡΤΗΣ ΔΙΦΥΛΛΟΥ
DESCRIPTION: DEAD BOLT LATCH

ΥΛΙΚΟ: ΣΥΣΚΕΥΑΣΙΑ: 1 - 10
MATERIAL: PACKAGE:

ΧΡΩΜΑ: **ΔΙΑΣΤΑΣΗ:**
COLOR: **DIMENSION:**



ΚΩΔΙΚΟΣ : 455-00-666-00 **STOCK No :**

ΠΕΡΙΓΡΑΦΗ: ΧΕΡΟΥΛΙ ΕΙΣΟΔΟΥ ΜΟΝΟ
DESCRIPTION: DOOR HANDLE INOX

ΥΛΙΚΟ: ΣΥΣΚΕΥΑΣΙΑ: 1 - 16
MATERIAL: PACKAGE:

ΧΡΩΜΑ: ΑΣΗΜΙ **ΔΙΑΣΤΑΣΗ:**
COLOR: SILVER **DIMENSION:**



ΚΩΔΙΚΟΣ : 455-00-660-00 **STOCK No :**

ΠΕΡΙΓΡΑΦΗ: ΧΕΡΟΥΛΙ ΦΕΓΓΙΤΗ ΜΕ ΓΩΝΙΑ
DESCRIPTION: HANDLE FOR HOPPER

ΥΛΙΚΟ: ΣΥΣΚΕΥΑΣΙΑ:
MATERIAL: PACKAGE:

ΧΡΩΜΑ: ΑΣΗΜΙ **ΔΙΑΣΤΑΣΗ:**
COLOR: SILVER **DIMENSION:**



ΚΩΔΙΚΟΣ : 455-52-203-02 **STOCK No :**

ΠΕΡΙΓΡΑΦΗ: ΧΕΡΟΥΛΙ ΕΙΣΟΔΟΥ ΔΙΠΛΟ MAXIMA
DESCRIPTION: PAIR OF DOOR HANDLES

ΥΛΙΚΟ: ΣΥΣΚΕΥΑΣΙΑ: 1 - 10
MATERIAL: PACKAGE:

ΧΡΩΜΑ: ΛΕΥΚΟ / WHITE **ΔΙΑΣΤΑΣΗ:**
COLOR: 455-52-204-03 ΜΑΥΡΟ / BLACK **DIMENSION:**

STOCK No :	ΚΩΔΙΚΟΣ : ART. No :	380-07-060-02
ΠΕΡΙΓΡΑΦΗ: DESCRIPTION:	ΣΠΑΝΙΟΛΕΤΑ ΜΗΧΑΝΙΣΜΟΥ HANDLE FOR WINDOWS	
ΥΛΙΚΟ: MATERIAL:	ΣΥΣΚΕΥΑΣΙΑ: 1 - 50 PACKAGE:	
ΧΡΩΜΑ: COLOR:	ΛΕΥΚΟ / WHITE 380-07-060-03 ΜΑΥΡΟ / BLACK	
	ΔΙΑΣΤΑΣΗ: DIMENSION:	



STOCK No :	ΚΩΔΙΚΟΣ : ART. No :	380-50-901-02
ΠΕΡΙΓΡΑΦΗ: DESCRIPTION:	ΧΕΡΟΥΛΙ ΜΗΧΑΝΙΣΜΟΥ ΜΕ ΚΛΕΙΔΙ GLOBO HANDLE FOR WINDOWS WITH KEY	
ΥΛΙΚΟ: MATERIAL:	ΣΥΣΚΕΥΑΣΙΑ: 10 - 40 PACKAGE:	
ΧΡΩΜΑ: COLOR:	ΛΕΥΚΟ / WHITE 380-50-902-03 ΜΑΥΡΟ / BLACK	
	ΔΙΑΣΤΑΣΗ: DIMENSION:	

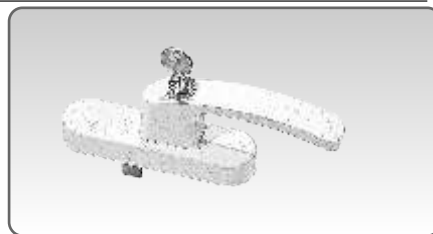

STOCK No :	ΚΩΔΙΚΟΣ : ART. No :	455-00-300-00
ΠΕΡΙΓΡΑΦΗ: DESCRIPTION:	ΧΕΡΟΥΛΙ ΕΙΣΟΔΟΥ ΜΟΝΟ ΣΩΛΗΝΩΤΟ, ΑΡΙΣΤ. PULL HANDLE - LEFT	ΚΩΔΙΚΟΙ: ART No: 455-30-000-00 ΔΕΞΙ / RIGHT
ΥΛΙΚΟ: MATERIAL:	INOX	
ΧΡΩΜΑ: COLOR:	ΑΣΗΜΙ SILVER	
	ΣΥΣΚΕΥΑΣΙΑ: 1 - 6 PACKAGE:	
	ΔΙΑΣΤΑΣΗ: Ø 32 X 650 mm DIMENSION:	

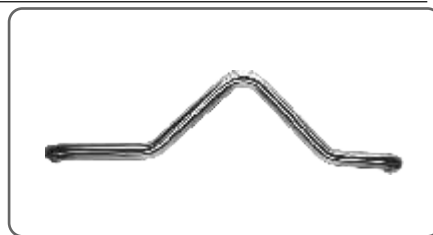

STOCK No :	ΚΩΔΙΚΟΣ : ART. No :	455-00-310-00
ΠΕΡΙΓΡΑΦΗ: DESCRIPTION:	ΧΕΡΟΥΛΙ ΕΙΣΟΔΟΥ ΜΟΝΟ ΣΩΛΗΝΩΤΟ, ΑΡΙΣΤ. PULL HANDLE - LEFT	ΚΩΔΙΚΟΙ: ART No: 455-31-000-00 ΔΕΞΙ / RIGHT
ΥΛΙΚΟ: MATERIAL:	INOX	
ΧΡΩΜΑ: COLOR:	ΑΣΗΜΙ SILVER	
	ΣΥΣΚΕΥΑΣΙΑ: 1 - 6 PACKAGE:	
	ΔΙΑΣΤΑΣΗ: Ø 32 X 500 mm DIMENSION:	

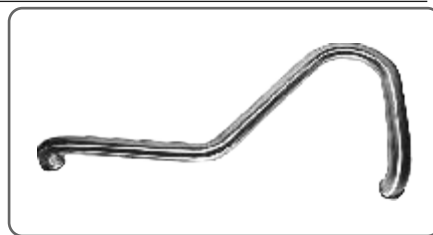

STOCK No :	ΚΩΔΙΚΟΣ : ART. No :	455-05-312-00
ΠΕΡΙΓΡΑΦΗ: DESCRIPTION:	ΧΕΡΟΥΛΙ ΕΙΣΟΔΟΥ ΜΟΝΟ ΣΩΛΗΝΩΤΟ DOOR HANDLE	
ΥΛΙΚΟ: MATERIAL:	INOX	
ΧΡΩΜΑ: COLOR:	ΑΣΗΜΙ SILVER	
	ΣΥΣΚΕΥΑΣΙΑ: 1 - 8 PACKAGE:	
	ΔΙΑΣΤΑΣΗ: Ø 32 X 300 mm DIMENSION:	



STOCK No :	ΚΩΔΙΚΟΣ : ART. No :	350-50-000-02
ΠΕΡΙΓΡΑΦΗ: DESCRIPTION:	ΜΕΝΤΕΣΕΣ ΔΙΠΛΟΣ HINGE	
ΥΛΙΚΟ: MATERIAL:	ΑΛΟΥΜΙΝΙΟ ALUMINIUM	
ΧΡΩΜΑ: COLOR:	ΛΕΥΚΟ / WHITE, 350-05-002-03 ΜΑΥΡΟ / BLACK	
	ΣΥΣΚΕΥΑΣΙΑ: 80 PACKAGE:	
	ΔΙΑΣΤΑΣΗ: DIMENSION:	

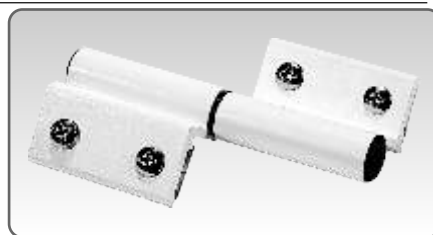

STOCK No :	ΚΩΔΙΚΟΣ : ART. No :	350-00-216-03
ΠΕΡΙΓΡΑΦΗ: DESCRIPTION:	ΜΕΝΤΕΣΕΣ ΔΙΠΛΟΣ HINGE	
ΥΛΙΚΟ: MATERIAL:	ΑΛΟΥΜΙΝΙΟ ALUMINIUM	
ΧΡΩΜΑ: COLOR:	ΜΑΥΡΟ / BLACK 350-00-216-02 ΛΕΥΚΟ / WHITE	
	ΣΥΣΚΕΥΑΣΙΑ: 50 - 300 PACKAGE:	
	ΔΙΑΣΤΑΣΗ: DIMENSION:	

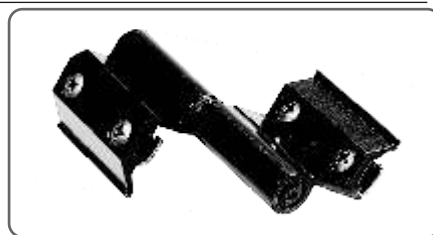

STOCK No :	ΚΩΔΙΚΟΣ : ART. No :	350-50-501-02
ΠΕΡΙΓΡΑΦΗ: DESCRIPTION:	ΜΕΝΤΕΣΕΣ 150 Kg HINGE 150 Kg	
ΥΛΙΚΟ: MATERIAL:	ΑΛΟΥΜΙΝΙΟ ALUMINIUM	
ΧΡΩΜΑ: COLOR:	ΛΕΥΚΟ / WHITE 350-50-502-03 ΜΑΥΡΟ / BLACK	
	ΣΥΣΚΕΥΑΣΙΑ: 5 - 40 PACKAGE:	
	ΔΙΑΣΤΑΣΗ: DIMENSION:	

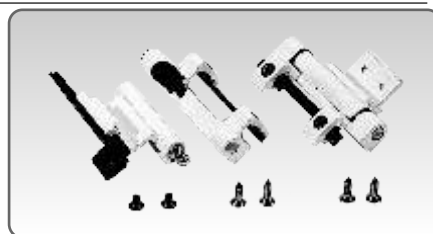

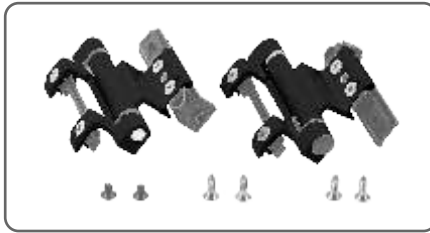

ΚΩΔΙΚΟΣ : 350-50-602-03 **STOCK No :**

ΠΕΡΙΓΡΑΦΗ: ΣΕΤ ΜΕΝΤΕΣΕ ΔΕΥΤΕΡΟΥ ΦΥΛΛΟΥ
DESCRIPTION: HINGE FOR SECOND LEAF

ΥΛΙΚΟ: ΑΛΟΥΜΙΝΙΟ **ΣΥΣΚΕΥΑΣΙΑ:** 5 - 40
MATERIAL: ALUMINIUM **PACKAGE:**

ΧΡΩΜΑ: ΜΑΥΡΟ **ΔΙΑΣΤΑΣΗ:**
COLOR: BLACK **DIMENSION:**

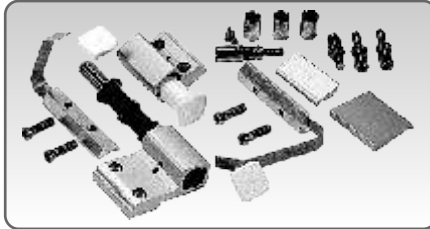

ΚΩΔΙΚΟΣ : 360-28-258-11 **STOCK No :**

ΠΕΡΙΓΡΑΦΗ: ΜΕΝΤΕΣΕΣ ΒΑΡΕΩΣ ΤΥΠΟΥ
DESCRIPTION: HINGE FOR DOORS

ΥΛΙΚΟ: ΑΛΟΥΜΙΝΙΟ **ΣΥΣΚΕΥΑΣΙΑ:** 1 - 25
MATERIAL: ALUMINIUM **PACKAGE:**

ΧΡΩΜΑ: ΑΣΗΜΙ ΑΝΟΔ. / SILVER ANOD **ΔΙΑΣΤΑΣΗ:**
COLOR: 350-28-258-03 ΜΑΥΡΟ / BLACK **DIMENSION:**

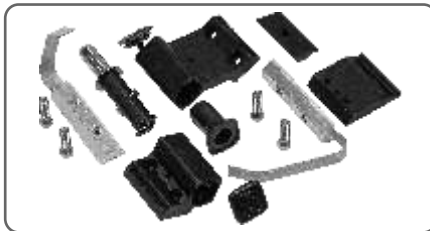

ΚΩΔΙΚΟΣ : 360-26-201-12 **STOCK No :**

ΠΕΡΙΓΡΑΦΗ: ΜΕΝΤΕΣΕΣ ΒΑΡΕΩΣ ΤΥΠΟΥ
DESCRIPTION: HINGE FOR DOORS

ΥΛΙΚΟ: ΑΛΟΥΜΙΝΙΟ **ΣΥΣΚΕΥΑΣΙΑ:** 1 - 25
MATERIAL: ALUMINIUM **PACKAGE:**

ΧΡΩΜΑ: ΜΑΥΡΗ ΑΝΟΔ. / BLACK ANOD. **ΔΙΑΣΤΑΣΗ:**
COLOR: 360-20-062-11 ΑΣΗΜΙ / SILVER, 360-28-262-00 ΛΕΥΚΟ /



ΚΩΔΙΚΟΣ : 350-16-058-02 **STOCK No :**

ΠΕΡΙΓΡΑΦΗ: ΜΥΛΟΣ ΠΕΡΙΣΤΡΕΦΟΜΕΝΟΥ ΒΑΡΕΩΣ ΤΥΠΟΥ
DESCRIPTION: FRICTION HINGE FOR PIVOT WINDOW

ΥΛΙΚΟ: ΑΛΟΥΜΙΝΙΟ **ΣΥΣΚΕΥΑΣΙΑ:** 2 - 10
MATERIAL: ALUMINIUM **PACKAGE:**

ΧΡΩΜΑ: ΛΕΥΚΟ / WHITE, 350-16-058-03 ΜΑΥΡΟ / BLACK **ΔΙΑΣΤΑΣΗ:**
COLOR: 350-16-058-09 ΑΣΗΜΙ / SILVER **DIMENSION:**

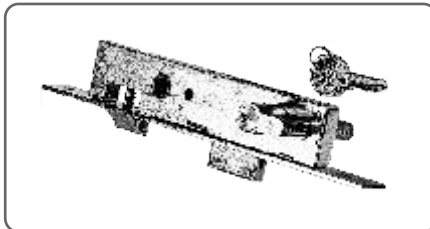

ΚΩΔΙΚΟΣ : 440-72-021-00 **STOCK No :**

ΠΕΡΙΓΡΑΦΗ: ΚΛΕΙΔΑΡΙΑ ΓΛΩΣΣΑΣ ΜΕ ΚΥΛΙΝΔΡΟ
DESCRIPTION: LOCKER PLUS CYLINDER

ΥΛΙΚΟ: ΑΤΣΑΛΙ **ΣΥΣΚΕΥΑΣΙΑ:** 1 - 25
MATERIAL: STEEL **PACKAGE:**

ΧΡΩΜΑ: ΑΣΗΜΙ **ΔΙΑΣΤΑΣΗ:** 20 mm
COLOR: SILVER **DIMENSION:**

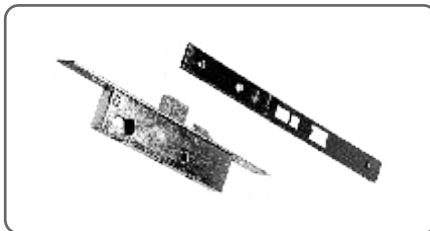

ΚΩΔΙΚΟΣ : 440-76-513-00 **STOCK No :**

ΠΕΡΙΓΡΑΦΗ: ΚΛΕΙΔΑΡΙΑ ΜΕ ΓΛΩΣΣΑ
DESCRIPTION: LOCKER

ΥΛΙΚΟ: ΙΝΟΧ **ΣΥΣΚΕΥΑΣΙΑ:** 1 - 20
MATERIAL: INOX **PACKAGE:**

ΧΡΩΜΑ: ΑΣΗΜΙ **ΔΙΑΣΤΑΣΗ:** 30 mm
COLOR: SILVER **DIMENSION:**

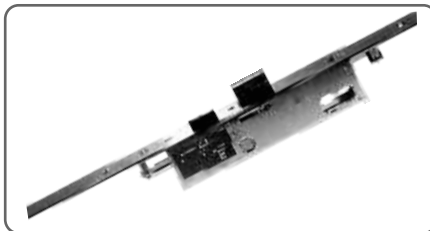

ΚΩΔΙΚΟΣ : 450-74-013-00 **STOCK No :**

ΠΕΡΙΓΡΑΦΗ: ΚΛΕΙΔΑΡΙΑ 3 ΣΗΜΕΙΩΝ 1570 mm
DESCRIPTION: 3 POINT LOCKER 1570 mm

ΥΛΙΚΟ: ΙΝΟΧ **ΣΥΣΚΕΥΑΣΙΑ:** 1 - 10
MATERIAL: INOX **PACKAGE:**

ΧΡΩΜΑ: ΑΣΗΜΙ **ΔΙΑΣΤΑΣΗ:** 35 mm
COLOR: SILVER **DIMENSION:**

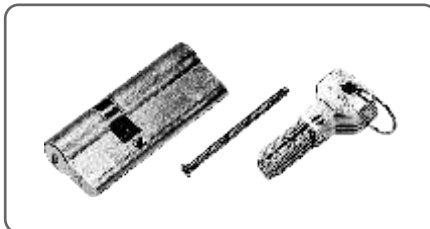

ΚΩΔΙΚΟΣ : 460-01-800-00 **STOCK No :**

ΠΕΡΙΓΡΑΦΗ: ΚΥΛΙΝΔΡΟΣ
DESCRIPTION: CYLINDER

ΥΛΙΚΟ: ΜΠΡΟΥΤΖΟΣ **ΣΥΣΚΕΥΑΣΙΑ:** 1 - 108
MATERIAL: BRONZE **PACKAGE:**

ΧΡΩΜΑ: ΝΙΚΕΛ **ΔΙΑΣΤΑΣΗ:** 80 mm
COLOR: NICKEL **DIMENSION:**

STOCK No :		ΚΩΔΙΚΟΣ : ART. No :	460-08-214-00
ΠΕΡΙΓΡΑΦΗ: DESCRIPTION:	ΚΥΛΙΝΔΡΟΣ CYLINDER		
ΥΛΙΚΟ: MATERIAL:	ΜΠΡΟΥΤΖΟΣ BRONZE	ΣΥΣΚΕΥΑΣΙΑ: PACKAGE:	1 - 10
ΧΡΩΜΑ: COLOR:	ΜΠΡΟΝΖΕ BRONZE	ΔΙΑΣΤΑΣΗ: DIMENSION:	82 mm



STOCK No :		ΚΩΔΙΚΟΣ : ART. No :	471-00-800-00
ΠΕΡΙΓΡΑΦΗ: DESCRIPTION:	ΑΝΕΜΟΦΡΑΧΤΗΣ WEATHER BARRIER		
ΥΛΙΚΟ: MATERIAL:	ΑΛΟΥΜΙΝΙΟ - EPDM ALUMINIUM - EPDM	ΣΥΣΚΕΥΑΣΙΑ: PACKAGE:	1 - 5
ΧΡΩΜΑ: COLOR:	ΑΒΑΦΟ MILL FINISH	ΔΙΑΣΤΑΣΗ: DIMENSION:	800 mm



STOCK No :		ΚΩΔΙΚΟΣ : ART. No :	471-00-900-00
ΠΕΡΙΓΡΑΦΗ: DESCRIPTION:	ΑΝΕΜΟΦΡΑΧΤΗΣ WEATHER BARRIER		
ΥΛΙΚΟ: MATERIAL:	ΑΛΟΥΜΙΝΙΟ - EPDM ALUMINIUM - EPDM	ΣΥΣΚΕΥΑΣΙΑ: PACKAGE:	1 - 5
ΧΡΩΜΑ: COLOR:	ΑΒΑΦΟ MILL FINISH	ΔΙΑΣΤΑΣΗ: DIMENSION:	900 mm



STOCK No :		ΚΩΔΙΚΟΣ : ART. No :	471-01-000-00
ΠΕΡΙΓΡΑΦΗ: DESCRIPTION:	ΑΝΕΜΟΦΡΑΧΤΗΣ WEATHER BARRIER		
ΥΛΙΚΟ: MATERIAL:	ΑΛΟΥΜΙΝΙΟ - EPDM ALUMINIUM - EPDM	ΣΥΣΚΕΥΑΣΙΑ: PACKAGE:	
ΧΡΩΜΑ: COLOR:	ΑΒΑΦΟ MILL FINISH	ΔΙΑΣΤΑΣΗ: DIMENSION:	1000 mm



STOCK No :		ΚΩΔΙΚΟΣ : ART. No :	471-01-100-00
ΠΕΡΙΓΡΑΦΗ: DESCRIPTION:	ΑΝΕΜΟΦΡΑΧΤΗΣ WEATHER BARRIER		
ΥΛΙΚΟ: MATERIAL:	ΑΛΟΥΜΙΝΙΟ - EPDM ALUMINIUM - EPDM	ΣΥΣΚΕΥΑΣΙΑ: PACKAGE:	
ΧΡΩΜΑ: COLOR:	ΑΒΑΦΟ MILL FINISH	ΔΙΑΣΤΑΣΗ: DIMENSION:	1100 mm



STOCK No :		ΚΩΔΙΚΟΣ : ART. No :	470-00-243-02
ΠΕΡΙΓΡΑΦΗ: DESCRIPTION:	ΑΕΡΟΠΛΑΝΑΚΙ FINGER PULL LOCK		
ΥΛΙΚΟ: MATERIAL:	ΑΛΟΥΜΙΝΙΟ - PVC ALUMINIUM - PVC	ΣΥΣΚΕΥΑΣΙΑ: PACKAGE:	50 - 350
ΧΡΩΜΑ: COLOR:	ΛΕΥΚΟ / WHITE 470-00-243-03 ΜΑΥΡΟ / BLACK	ΔΙΑΣΤΑΣΗ: DIMENSION:	

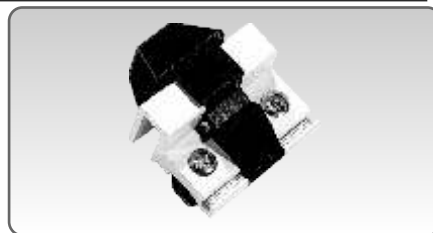

STOCK No :		ΚΩΔΙΚΟΣ : ART. No :	300-09-398-00
ΠΕΡΙΓΡΑΦΗ: DESCRIPTION:	ΤΑΠΕΣ ΣΤΕΓΑΝΩΣΗΣ ΔΙΦΥΛΛΟΥ ΠΑΤΖΟΥΡΙΟΥ END COVER		
ΥΛΙΚΟ: MATERIAL:	ΠΟΛΥΑΜΙΔΙΟ POLYAMIDE	ΣΥΣΚΕΥΑΣΙΑ: PACKAGE:	150
ΧΡΩΜΑ: COLOR:	ΜΑΥΡΟ BLACK	ΠΡΟΦΙΛ: PROFILE:	M9398

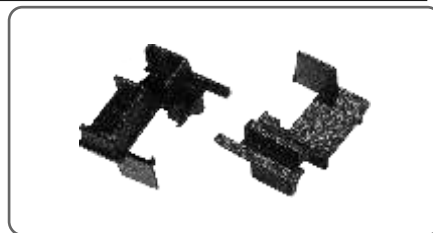

STOCK No :		ΚΩΔΙΚΟΣ : ART. No :	300-15-004-00
ΠΕΡΙΓΡΑΦΗ: DESCRIPTION:	ΤΑΠΕΣ ΣΤΕΓΑΝΩΣΗΣ ΔΙΦΥΛΛΟΥ END COVER		
ΥΛΙΚΟ: MATERIAL:	ΠΟΛΥΑΜΙΔΙΟ POLYAMIDE	ΣΥΣΚΕΥΑΣΙΑ: PACKAGE:	120
ΧΡΩΜΑ: COLOR:	ΜΑΥΡΟ BLACK	ΠΡΟΦΙΛ: PROFILE:	M15004

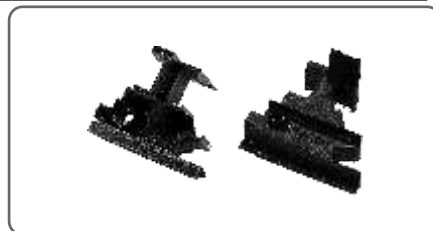

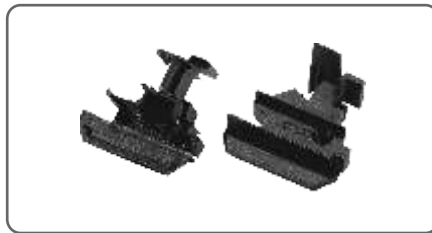

ΚΩΔΙΚΟΣ : 300-15-005-00 **STOCK No :**

ΠΕΡΙΓΡΑΦΗ: ΤΑΠΕΣ ΣΤΕΓΑΝΩΣΗΣ ΔΙΦΥΛΛΟΥ
DESCRIPTION: END COVER

ΥΛΙΚΟ: ΠΟΛΥΑΜΙΔΙΟ
MATERIAL: POLYAMIDE

ΣΥΣΚΕΥΑΣΙΑ: 120
PACKAGE:

ΧΡΩΜΑ: ΜΑΥΡΟ
COLOR: BLACK

ΠΡΟΦΙΛ: M15005
PROFILE:

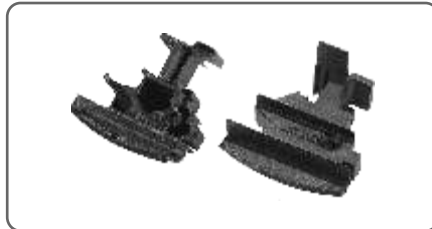

ΚΩΔΙΚΟΣ : 300-15-006-00 **STOCK No :**

ΠΕΡΙΓΡΑΦΗ: ΤΑΠΕΣ ΣΤΕΓΑΝΩΣΗΣ ΔΙΦΥΛΛΟΥ
DESCRIPTION: END COVER

ΥΛΙΚΟ: ΠΟΛΥΑΜΙΔΙΟ
MATERIAL: POLYAMIDE

ΣΥΣΚΕΥΑΣΙΑ: 120
PACKAGE:

ΧΡΩΜΑ: ΜΑΥΡΟ
COLOR: BLACK

ΠΡΟΦΙΛ: M15006
PROFILE:

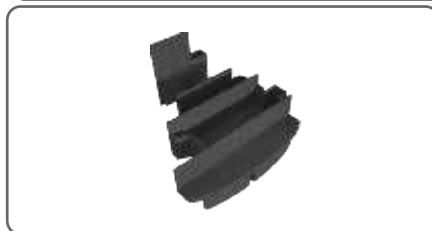

ΚΩΔΙΚΟΣ : 300-15-375-00 **STOCK No :**

ΠΕΡΙΓΡΑΦΗ: ΤΑΠΕΣ ΣΤΕΓΑΝΩΣΗΣ ΔΙΦΥΛΛΟΥ
DESCRIPTION: END COVER

ΥΛΙΚΟ: ΠΟΛΥΑΜΙΔΙΟ
MATERIAL: POLYAMIDE

ΣΥΣΚΕΥΑΣΙΑ:
PACKAGE:

ΧΡΩΜΑ: ΜΑΥΡΟ
COLOR: BLACK

ΠΡΟΦΙΛ: M15375
PROFILE:

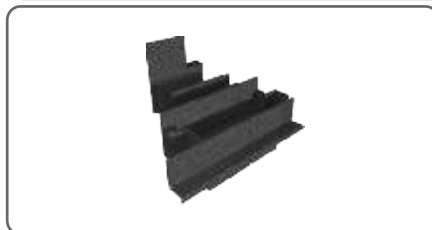

ΚΩΔΙΚΟΣ : 300-15-379-00 **STOCK No :**

ΠΕΡΙΓΡΑΦΗ: ΤΑΠΕΣ ΣΤΕΓΑΝΩΣΗΣ ΔΙΦΥΛΛΟΥ
DESCRIPTION: END COVER

ΥΛΙΚΟ: ΠΟΛΥΑΜΙΔΙΟ
MATERIAL: POLYAMIDE

ΣΥΣΚΕΥΑΣΙΑ:
PACKAGE:

ΧΡΩΜΑ: ΜΑΥΡΟ
COLOR: BLACK

ΠΡΟΦΙΛ: M15379
PROFILE:

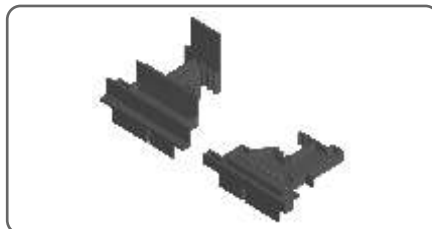

ΚΩΔΙΚΟΣ : 300-25-004-03 **STOCK No :**

ΠΕΡΙΓΡΑΦΗ: ΤΑΠΕΣ ΣΤΕΓΑΝΩΣΗΣ ΔΙΦΥΛΛΟΥ
DESCRIPTION: END COVER

ΥΛΙΚΟ: ΠΟΛΥΑΜΙΔΙΟ
MATERIAL: POLYAMIDE

ΣΥΣΚΕΥΑΣΙΑ:
PACKAGE:

ΧΡΩΜΑ: ΜΑΥΡΟ
COLOR: BLACK

ΠΡΟΦΙΛ: M15004
PROFILE:

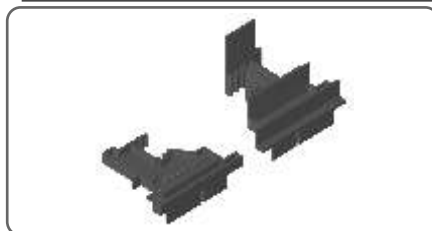

ΚΩΔΙΚΟΣ : 300-25-004-13 **STOCK No :**

ΠΕΡΙΓΡΑΦΗ: ΤΑΠΕΣ ΣΤΕΓΑΝΩΣΗΣ ΔΙΦΥΛΛΟΥ
DESCRIPTION: END COVER

ΥΛΙΚΟ: ΠΟΛΥΑΜΙΔΙΟ
MATERIAL: POLYAMIDE

ΣΥΣΚΕΥΑΣΙΑ:
PACKAGE:

ΧΡΩΜΑ: ΜΑΥΡΟ
COLOR: BLACK

ΠΡΟΦΙΛ: M15004
PROFILE:



ΚΩΔΙΚΟΣ : 300-25-191-03 **STOCK No :**

ΠΕΡΙΓΡΑΦΗ: ΤΑΠΕΣ ΣΤΕΓΑΝΩΣΗΣ ΔΙΦΥΛΛΟΥ
DESCRIPTION: END COVER

ΥΛΙΚΟ: ΠΟΛΥΑΜΙΔΙΟ
MATERIAL: POLYAMIDE

ΣΥΣΚΕΥΑΣΙΑ:
PACKAGE:

ΧΡΩΜΑ: ΜΑΥΡΟ
COLOR: BLACK

ΠΡΟΦΙΛ: M15191
PROFILE:

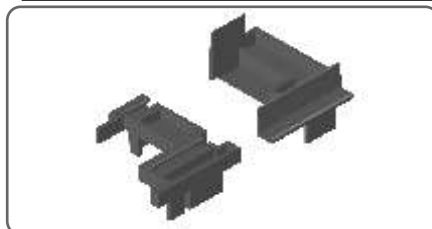

ΚΩΔΙΚΟΣ : 300-25-191-13 **STOCK No :**

ΠΕΡΙΓΡΑΦΗ: ΤΑΠΕΣ ΣΤΕΓΑΝΩΣΗΣ ΔΙΦΥΛΛΟΥ
DESCRIPTION: END COVER

ΥΛΙΚΟ: ΠΟΛΥΑΜΙΔΙΟ
MATERIAL: POLYAMIDE

ΣΥΣΚΕΥΑΣΙΑ:
PACKAGE:

ΧΡΩΜΑ: ΜΑΥΡΟ
COLOR: BLACK

ΠΡΟΦΙΛ: M15191
PROFILE:

STOCK No :		ΚΩΔΙΚΟΣ : ART. No :	310-15-182-00
ΠΕΡΙΓΡΑΦΗ: DESCRIPTION:	ΤΑΠΕΣ ΣΤΕΓΑΝΩΣΗΣ ΦΥΛΛΟΥ END COVER		
ΥΛΙΚΟ: MATERIAL:	ΠΟΛΥΑΜΙΔΙΟ POLYAMIDE	ΣΥΣΚΕΥΑΣΙΑ: PACKAGE:	
ΧΡΩΜΑ: COLOR:	ΜΑΥΡΟ BLACK	ΠΡΟΦΙΛ: PROFILE:	M15076



STOCK No :		ΚΩΔΙΚΟΣ : ART. No :	310-15-076-03
ΠΕΡΙΓΡΑΦΗ: DESCRIPTION:	ΤΑΠΕΣ ΣΤΕΓΑΝΩΣΗΣ ΦΥΛΛΟΥ SASH SEALANT		
ΥΛΙΚΟ: MATERIAL:	ΠΟΛΥΑΜΙΔΙΟ POLYAMIDE	ΣΥΣΚΕΥΑΣΙΑ: PACKAGE:	
ΧΡΩΜΑ: COLOR:	ΜΑΥΡΟ BLACK	ΠΡΟΦΙΛ: PROFILE:	M15076, 15182

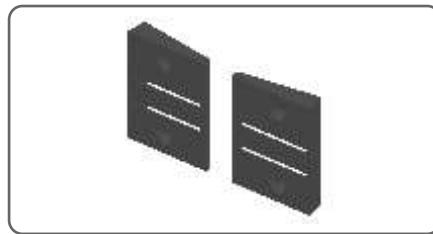

STOCK No :		ΚΩΔΙΚΟΣ : ART. No :	310-09-317-00
ΠΕΡΙΓΡΑΦΗ: DESCRIPTION:	ΤΑΠΑ ΕΞΩΤΕΡΙΚΟΥ ΝΕΡΟΧΥΤΗ 9317 END COVER		
ΥΛΙΚΟ: MATERIAL:	ΠΟΛΥΑΜΙΔΙΟ POLYAMIDE	ΔΙΑΣΤΑΣΗ: DIMENSION:	1 - 70 X 120
ΧΡΩΜΑ: COLOR:	ΜΑΥΡΟ / ΛΕΥΚΟ BLACK / WHITE	ΠΡΟΦΙΛ: PROFILE:	M9317



STOCK No :		ΚΩΔΙΚΟΣ : ART. No :	310-11-116-00
ΠΕΡΙΓΡΑΦΗ: DESCRIPTION:	ΤΑΠΑ ΝΕΡΟΧΥΤΗ END COVER		
ΥΛΙΚΟ: MATERIAL:	ΠΟΛΥΑΜΙΔΙΟ POLYAMIDE	ΣΥΣΚΕΥΑΣΙΑ: PACKAGE:	1 - 120 X 70
ΧΡΩΜΑ: COLOR:	ΛΕΥΚΟ / ΓΚΡΙ / ΜΑΥΡΟ WHITE / GREY / BLACK	ΔΙΑΣΤΑΣΗ: DIMENSION:	



STOCK No :		ΚΩΔΙΚΟΣ : ART. No :	310-11-226-13
ΠΕΡΙΓΡΑΦΗ: DESCRIPTION:	ΤΑΠΑ ΝΕΡΟΧΥΤΗ END COVER		
ΥΛΙΚΟ: MATERIAL:	ΠΟΛΥΑΜΙΔΙΟ POLYAMIDE	ΣΥΣΚΕΥΑΣΙΑ: PACKAGE:	
ΧΡΩΜΑ: COLOR:	ΜΑΥΡΟ BLACK	ΔΙΑΣΤΑΣΗ: DIMENSION:	

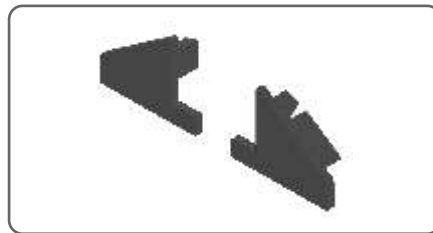

STOCK No :		ΚΩΔΙΚΟΣ : ART. No :	310-11-501-00
ΠΕΡΙΓΡΑΦΗ: DESCRIPTION:	ΝΕΡΟΧΥΤΗΣ WATER CAP		
ΥΛΙΚΟ: MATERIAL:	ΠΟΛΥΑΜΙΔΙΟ POLYAMIDE	ΣΥΣΚΕΥΑΣΙΑ: PACKAGE:	1 - 100 X 35
ΧΡΩΜΑ: COLOR:	ΛΕΥΚΟ / ΓΚΡΙ / ΜΑΥΡΟ WHITE / GREY / BLACK	ΔΙΑΣΤΑΣΗ: DIMENSION:	

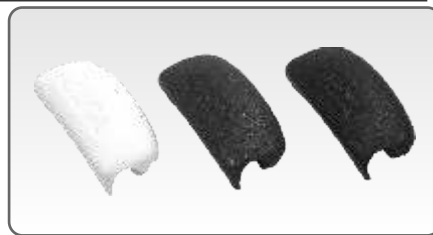

STOCK No :		ΚΩΔΙΚΟΣ : ART. No :	310-15-170-00
ΠΕΡΙΓΡΑΦΗ: DESCRIPTION:	ΤΑΠΑ ΠΡΟΣΘΕΤΟΥ END COVER		
ΥΛΙΚΟ: MATERIAL:	ΠΟΛΥΑΜΙΔΙΟ POLYAMIDE	ΣΥΣΚΕΥΑΣΙΑ: PACKAGE:	
ΧΡΩΜΑ: COLOR:	ΜΑΥΡΟ BLACK	ΔΙΑΣΤΑΣΗ: DIMENSION:	

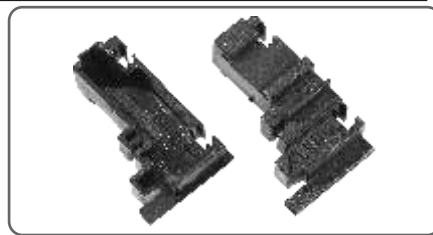

STOCK No :		ΚΩΔΙΚΟΣ : ART. No :	310-15-171-00
ΠΕΡΙΓΡΑΦΗ: DESCRIPTION:	ΤΑΠΑ ΣΤΕΓΑΝΩΣΗΣ ΣΤΟ ΚΑΤΩ ΜΕΡΟΣ ΕΙΣ. END COVER		
ΥΛΙΚΟ: MATERIAL:	ΠΟΛΥΑΜΙΔΙΟ POLYAMIDE	ΣΥΣΚΕΥΑΣΙΑ: PACKAGE:	
ΧΡΩΜΑ: COLOR:	ΜΑΥΡΟ BLACK	ΔΙΑΣΤΑΣΗ: DIMENSION:	

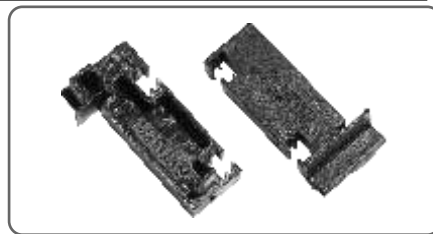

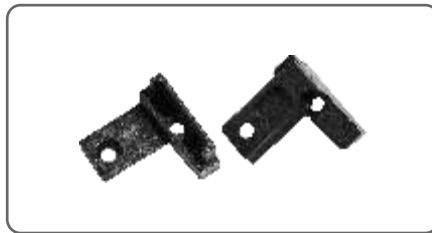

ΚΩΔΙΚΟΣ : 310-15-172-00 **STOCK No :**

ΠΕΡΙΓΡΑΦΗ: ΣΥΝΔΕΣΜΟΣ ΚΑΤΩΚΑΣΙΟΥ
DESCRIPTION: THRESHOLD CONNECTOR

ΥΛΙΚΟ: ΠΟΛΥΑΜΙΔΙΟ
MATERIAL: POLYAMIDE

ΣΥΣΚΕΥΑΣΙΑ:
PACKAGE:

ΧΡΩΜΑ: ΜΑΥΡΟ
COLOR: BLACK

ΔΙΑΣΤΑΣΗ:
DIMENSION:



ΚΩΔΙΚΟΣ : 310-15-577-00 **STOCK No :**

ΠΕΡΙΓΡΑΦΗ: ΤΑΠΑ ΓΙΑ ΚΑΤΩΚΑΣΙ
DESCRIPTION: THRESHOLD CONNECTOR

ΥΛΙΚΟ: ΠΟΛΥΑΜΙΔΙΟ
MATERIAL: POLYAMIDE

ΣΥΣΚΕΥΑΣΙΑ:
PACKAGE:

ΧΡΩΜΑ: ΜΑΥΡΟ
COLOR: BLACK

ΠΡΟΦΙΛ: M15577
PROFILE:

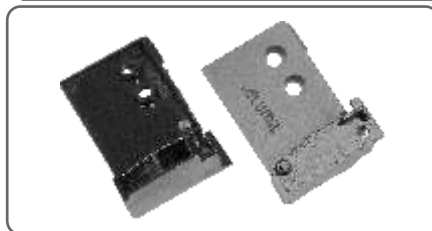

ΚΩΔΙΚΟΣ : 310-15-195-00 **STOCK No :**

ΠΕΡΙΓΡΑΦΗ: ΤΑΠΑ ΓΙΑ ΚΑΤΩΚΑΣΙ
DESCRIPTION: THRESHOLD CONNECTOR

ΥΛΙΚΟ: ΠΟΛΥΑΜΙΔΙΟ
MATERIAL: POLYAMIDE

ΣΥΣΚΕΥΑΣΙΑ:
PACKAGE:

ΧΡΩΜΑ: ΜΑΥΡΟ
COLOR: BLACK

ΔΙΑΣΤΑΣΗ:
DIMENSION:

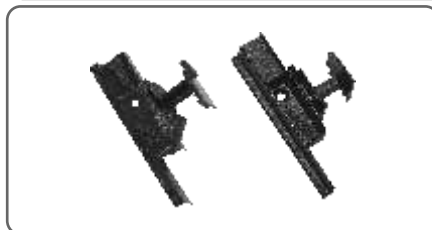

ΚΩΔΙΚΟΣ : 300-15-458-00 **STOCK No :**

ΠΕΡΙΓΡΑΦΗ: ΤΑΠΑ ΜΠΙΝΙΟΥ ΚΡΥΦΟΥ ΦΥΛΛΟΥ
DESCRIPTION: END COVER

ΥΛΙΚΟ: ΠΟΛΥΑΜΙΔΙΟ
MATERIAL: POLYAMIDE

ΣΥΣΚΕΥΑΣΙΑ:
PACKAGE:

ΧΡΩΜΑ: ΜΑΥΡΟ
COLOR: BLACK

ΔΙΑΣΤΑΣΗ:
DIMENSION:

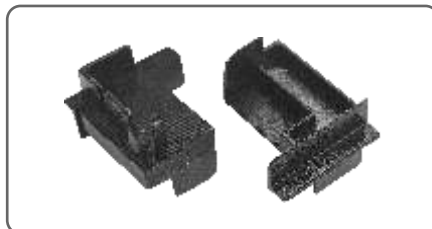

ΚΩΔΙΚΟΣ : 310-15-191-00 **STOCK No :**

ΠΕΡΙΓΡΑΦΗ: ΤΑΠΑ ΜΠΙΝΙΟΥ ΕΙΣΟΔΟΥ ΑΝΟΙΓ. ΜΕΣΑ
DESCRIPTION: END COVER

ΥΛΙΚΟ: ΠΟΛΥΑΜΙΔΙΟ
MATERIAL: POLYAMIDE

ΣΥΣΚΕΥΑΣΙΑ:
PACKAGE:

ΧΡΩΜΑ: ΜΑΥΡΟ
COLOR: BLACK

ΔΙΑΣΤΑΣΗ:
DIMENSION:



ΚΩΔΙΚΟΣ : 311-00-110-03 **STOCK No :**

ΠΕΡΙΓΡΑΦΗ: ΤΑΠΑ Ø11 - ΟΒΑΛ
DESCRIPTION: SCREW COVER

ΥΛΙΚΟ: ΠΟΛΥΑΜΙΔΙΟ
MATERIAL: POLYAMIDE

ΣΥΣΚΕΥΑΣΙΑ:
PACKAGE:

ΧΡΩΜΑ: ΜΑΥΡΟ / BLACK, 311-00-110-02 ΛΕΥΚΟ / WHITE,
COLOR: 311-00-110-04 ΓΚΡΙ / GREY, 311-00-110-05 ΚΑΦΕ / BROWN



ΚΩΔΙΚΟΣ : 310-01-994-03 **STOCK No :**

ΠΕΡΙΓΡΑΦΗ: ΤΑΠΑ Ø11 ΓΙΑ ΑΝΟΙΚΤΑ ΠΡΟΦΙΛ
DESCRIPTION: CAP FOR SCREWS

ΥΛΙΚΟ: ΠΟΛΥΑΜΙΔΙΟ
MATERIAL: POLYAMIDE

ΣΥΣΚΕΥΑΣΙΑ:
PACKAGE:

ΧΡΩΜΑ: ΜΑΥΡΟ / BLACK
COLOR: 310-01-994-02 ΛΕΥΚΟ / WHITE

ΔΙΑΣΤΑΣΗ:
DIMENSION:



ΚΩΔΙΚΟΣ : 290-00-002-00 **STOCK No :**

ΠΕΡΙΓΡΑΦΗ: ΤΑΚΑΚΙ ΤΖΑΜΙΟΥ
DESCRIPTION: GLAZING WEDGE

ΥΛΙΚΟ: PVC
MATERIAL:

ΣΥΣΚΕΥΑΣΙΑ: 1500
PACKAGE:

ΧΡΩΜΑ: ΜΑΥΡΟ
COLOR: BLACK

ΔΙΑΣΤΑΣΗ: 2 mm
DIMENSION:

STOCK No :		ΚΩΔΙΚΟΣ : ART. No :	290-00-003-00
ΠΕΡΙΓΡΑΦΗ: DESCRIPTION:	ΤΑΚΑΚΙ ΤΖΑΜΙΟΥ GLAZING WEDGE		
ΥΛΙΚΟ: MATERIAL:	PVC	ΣΥΣΚΕΥΑΣΙΑ: PACKAGE:	1 - 4 (X 1000)
ΧΡΩΜΑ: COLOR:	ΚΑΦΕ BROWN	ΔΙΑΣΤΑΣΗ: DIMENSION:	3 mm



STOCK No :		ΚΩΔΙΚΟΣ : ART. No :	290-00-004-00
ΠΕΡΙΓΡΑΦΗ: DESCRIPTION:	ΤΑΚΑΚΙ ΤΖΑΜΙΟΥ GLAZING WEDGE		
ΥΛΙΚΟ: MATERIAL:	PVC	ΣΥΣΚΕΥΑΣΙΑ: PACKAGE:	800
ΧΡΩΜΑ: COLOR:	ΜΠΟΡΝΤΩ REDWINE	ΔΙΑΣΤΑΣΗ: DIMENSION:	4 mm



STOCK No :		ΚΩΔΙΚΟΣ : ART. No :	290-00-005-00
ΠΕΡΙΓΡΑΦΗ: DESCRIPTION:	ΤΑΚΑΚΙ ΤΖΑΜΙΟΥ GLAZING WEDGE		
ΥΛΙΚΟ: MATERIAL:	PVC	ΣΥΣΚΕΥΑΣΙΑ: PACKAGE:	600
ΧΡΩΜΑ: COLOR:	ΜΑΥΡΟ BLACK	ΔΙΑΣΤΑΣΗ: DIMENSION:	5 mm



STOCK No :		ΚΩΔΙΚΟΣ : ART. No :	472-00-490-00
ΠΕΡΙΓΡΑΦΗ: DESCRIPTION:	ΚΑΠΑΚΙ ΑΝΟΞΕΙΔΩΤΟ ΓΙΑ TS490 INOX CAP FOR TS490		
ΥΛΙΚΟ: MATERIAL:		ΣΥΣΚΕΥΑΣΙΑ: PACKAGE:	
ΧΡΩΜΑ: COLOR:		ΔΙΑΣΤΑΣΗ: DIMENSION:	

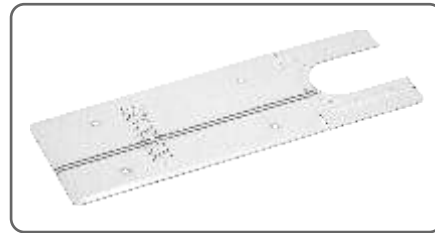

STOCK No :		ΚΩΔΙΚΟΣ : ART. No :	472-10-100-00
ΠΕΡΙΓΡΑΦΗ: DESCRIPTION:	ΣΟΥΣΤΑ ΕΠΑΝΑΦΟΡΑΣ ΔΑΠΕΔΟΥ, 1000 mm FLOOR CLOSER, 1000 mm		
ΥΛΙΚΟ: MATERIAL:		ΣΥΣΚΕΥΑΣΙΑ: PACKAGE:	
ΧΡΩΜΑ: COLOR:		ΔΙΑΣΤΑΣΗ: DIMENSION:	

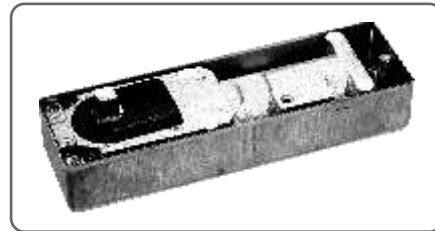

STOCK No :		ΚΩΔΙΚΟΣ : ART. No :	472-15-020-00
ΠΕΡΙΓΡΑΦΗ: DESCRIPTION:	ΜΠΡΑΤΣΟ ΓΙΑ ΣΟΥΣΤΑ TS490N ARM FOR DOOR CLOSER TS490N		
ΥΛΙΚΟ: MATERIAL:		ΣΥΣΚΕΥΑΣΙΑ: PACKAGE:	
ΧΡΩΜΑ: COLOR:		ΔΙΑΣΤΑΣΗ: DIMENSION:	

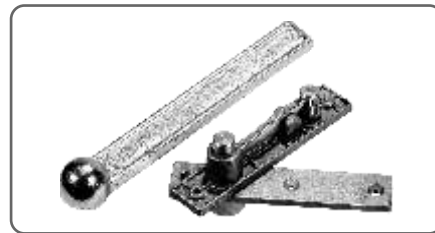

STOCK No :		ΚΩΔΙΚΟΣ : ART. No :	472-12-012-11
ΠΕΡΙΓΡΑΦΗ: DESCRIPTION:	ΣΟΥΣΤΑ ΕΠΑΝΑΦΟΡΑΣ - 1250 mm DOOR CLOSER - 1250 mm		
ΥΛΙΚΟ: MATERIAL:		ΣΥΣΚΕΥΑΣΙΑ: PACKAGE:	
ΧΡΩΜΑ: COLOR:	ΑΣΗΜΙ ΑΝΟΔ. / SILVER ANOD.		

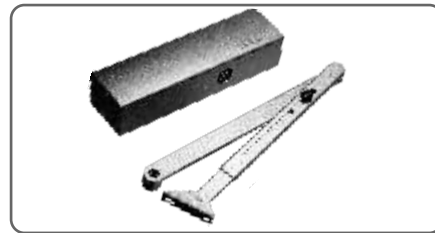

STOCK No :		ΚΩΔΙΚΟΣ : ART. No :	800-15-000-00
ΠΕΡΙΓΡΑΦΗ: DESCRIPTION:	ΠΡΕΣΑΚΙ ΑΕΡΟΣ M15000 PNEUMATIC PUNCH MACHINE		
ΥΛΙΚΟ: MATERIAL:		ΣΥΣΚΕΥΑΣΙΑ: PACKAGE:	
ΧΡΩΜΑ: COLOR:		ΔΙΑΣΤΑΣΗ: DIMENSION:	

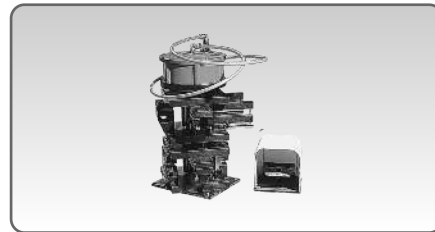



ΚΩΔΙΚΟΣ : 852-15-026-00 **STOCK No :**

ART. No : 852-15-026-00
ΠΕΡΙΓΡΑΦΗ: ΞΥΛΟΥΡΙΣΤΙΚΟ
DESCRIPTION: MILLING BIT

ΥΛΙΚΟ: **ΣΥΣΚΕΥΑΣΙΑ:**
MATERIAL: **PACKAGE:**

ΧΡΩΜΑ: M15026, M15027 **ΠΡΟΦΙΛ:**
COLOR: **PROFILE:**



ΚΩΔΙΚΟΣ : 852-15-070-00 **STOCK No :**

ART. No : 852-15-070-00
ΠΕΡΙΓΡΑΦΗ: ΞΥΛΟΥΡΙΣΤΙΚΟ
DESCRIPTION: MILLING BIT

ΥΛΙΚΟ: **ΣΥΣΚΕΥΑΣΙΑ:**
MATERIAL: **PACKAGE:**

ΠΡΟΦΙΛ: M15070, M15071, M15074, M15181 **ΠΡΟΦΙΛ:**
PROFILE: **PROFILE:**



ΚΩΔΙΚΟΣ : 852-15-083-00 **STOCK No :**

ART. No : 852-15-083-00
ΠΕΡΙΓΡΑΦΗ: ΞΥΛΟΥΡΙΣΤΙΚΟ
DESCRIPTION: MILLING BIT

ΥΛΙΚΟ: **ΣΥΣΚΕΥΑΣΙΑ:**
MATERIAL: **PACKAGE:**

ΠΡΟΦΙΛ: M15080, M15082, M15083, M15084 **ΔΙΑΣΤΑΣΗ:**
PROFILE: **DIMENSION:**



ΚΩΔΙΚΟΣ : 852-15-088-00 **STOCK No :**

ART. No : 852-15-088-00
ΠΕΡΙΓΡΑΦΗ: ΞΥΛΟΥΡΙΣΤΙΚΟ
DESCRIPTION: MILLING BIT

ΥΛΙΚΟ: **ΣΥΣΚΕΥΑΣΙΑ:**
MATERIAL: **PACKAGE:**

ΠΡΟΦΙΛ: M15025, M15085, M15086, M15088 **ΔΙΑΣΤΑΣΗ:**
PROFILE: **DIMENSION:**



ΚΩΔΙΚΟΣ : 852-15-416-00 **STOCK No :**

ART. No : 852-15-416-00
ΠΕΡΙΓΡΑΦΗ: ΞΥΛΟΥΡΙΣΤΙΚΟ
DESCRIPTION: MILLING BIT

ΥΛΙΚΟ: **ΣΥΣΚΕΥΑΣΙΑ:**
MATERIAL: **PACKAGE:**

ΠΡΟΦΙΛ: M15416 **ΔΙΑΣΤΑΣΗ:**
PROFILE: **DIMENSION:**



ΚΩΔΙΚΟΣ : 852-15-060-00 **STOCK No :**

ART. No : 852-15-060-00
ΠΕΡΙΓΡΑΦΗ: ΞΥΛΟΥΡΙΣΤΙΚΟ
DESCRIPTION: MILLING BIT

ΥΛΙΚΟ: **ΣΥΣΚΕΥΑΣΙΑ:**
MATERIAL: **PACKAGE:**

ΠΡΟΦΙΛ: M15060, M15062, M15064, M15065, M15066, M15067,
PROFILE: M15068, M15142, M15143, M15157, M15192, M15266























ΚΩΔΙΚΟΣ : 720-04-918-00 **STOCK No :**









ART. No : 720-04-918-00
ΠΕΡΙΓΡΑΦΗ: ΑΥΤΟΚΟΛΛΗΤΗ ΤΑΙΝΙΑ ΔΙΠΛΗΣ ΟΨΗΣ
DESCRIPTION: SELF-ADHESIVE TAPE

ΥΛΙΚΟ: **ΣΥΣΚΕΥΑΣΙΑ:**
MATERIAL: **PACKAGE:**

ΧΡΩΜΑ: ΔΙΑΦΑΝΟ **ΔΙΑΣΤΑΣΗ:**
COLOR: TRANSPARENT **DIMENSION:**

STOCK No :	ΚΩΔΙΚΟΣ : ART. No :	200-02-050-00	
ΠΕΡΙΓΡΑΦΗ: DESCRIPTION:	ΛΑΣΤΙΧΟ ΣΦΗΝΑ 5 mm GLAZING GASKET 5 mm		
ΥΛΙΚΟ: MATERIAL:	PVC	ΧΡΩΜΑ: COLOR:	MAYPO BLACK
STOCK No :	ΚΩΔΙΚΟΣ : ART. No :	200-02-070-00	
ΠΕΡΙΓΡΑΦΗ: DESCRIPTION:	ΛΑΣΤΙΧΟ ΣΦΗΝΑ 4 mm GLAZING GASKET 4 mm		
ΥΛΙΚΟ: MATERIAL:	PVC	ΧΡΩΜΑ: COLOR:	MAYPO BLACK
STOCK No :	ΚΩΔΙΚΟΣ : ART. No :	200-02-300-00	
ΠΕΡΙΓΡΑΦΗ: DESCRIPTION:	ΛΑΣΤΙΧΟ ΣΦΗΝΑ 7 mm GLAZING GASKET 7 mm		
ΥΛΙΚΟ: MATERIAL:	PVC	ΧΡΩΜΑ: COLOR:	MAYPO BLACK
STOCK No :	ΚΩΔΙΚΟΣ : ART. No :	200-02-700-00	
ΠΕΡΙΓΡΑΦΗ: DESCRIPTION:	ΛΑΣΤΙΧΟ ΣΦΗΝΑ 3 mm GLAZING GASKET 3 mm		
ΥΛΙΚΟ: MATERIAL:	PVC	ΧΡΩΜΑ: COLOR:	MAYPO BLACK
STOCK No :	ΚΩΔΙΚΟΣ : ART. No :	200-02-800-00	
ΠΕΡΙΓΡΑΦΗ: DESCRIPTION:	ΛΑΣΤΙΧΟ ΣΦΗΝΑ 8 mm GLAZING GASKET 8 mm		
ΥΛΙΚΟ: MATERIAL:	PVC	ΧΡΩΜΑ: COLOR:	MAYPO BLACK
STOCK No :	ΚΩΔΙΚΟΣ : ART. No :	200-03-004-00	
ΠΕΡΙΓΡΑΦΗ: DESCRIPTION:	ΛΑΣΤΙΧΟ ΤΖΑΜΙΟΥ ΣΦΗΝΑ 4 mm GLAZING GASKET 4 mm		
ΥΛΙΚΟ: MATERIAL:	PVC	ΧΡΩΜΑ: COLOR:	MAYPO BLACK
STOCK No :	ΚΩΔΙΚΟΣ : ART. No :	200-03-005-00	
ΠΕΡΙΓΡΑΦΗ: DESCRIPTION:	ΛΑΣΤΙΧΟ ΤΖΑΜΙΟΥ ΣΦΗΝΑ 5 mm GLAZING GASKET 5 mm		
ΥΛΙΚΟ: MATERIAL:	PVC	ΧΡΩΜΑ: COLOR:	MAYPO BLACK
STOCK No :	ΚΩΔΙΚΟΣ : ART. No :	200-04-023-01	
ΠΕΡΙΓΡΑΦΗ: DESCRIPTION:	ΛΑΣΤΙΧΟ ΣΦΗΝΑ 2-4 mm GLAZING GASKET 2-4 mm		
ΥΛΙΚΟ: MATERIAL:	EPDM	ΧΡΩΜΑ: COLOR:	MAYPO BLACK
STOCK No :	ΚΩΔΙΚΟΣ : ART. No :	200-04-045-01	
ΠΕΡΙΓΡΑΦΗ: DESCRIPTION:	ΛΑΣΤΙΧΟ ΣΦΗΝΑ 4-6 mm GLAZING GASKET 4-6 mm		
ΥΛΙΚΟ: MATERIAL:	EPDM	ΧΡΩΜΑ: COLOR:	MAYPO BLACK
STOCK No :	ΚΩΔΙΚΟΣ : ART. No :	200-04-067-01	
ΠΕΡΙΓΡΑΦΗ: DESCRIPTION:	ΛΑΣΤΙΧΟ ΣΦΗΝΑ 6-8 mm GLAZING GASKET 6-8 mm		
ΥΛΙΚΟ: MATERIAL:	EPDM	ΧΡΩΜΑ: COLOR:	MAYPO BLACK

	<p>ΚΩΔΙΚΟΣ : 200-05-304-00 <small>STOCK No :</small></p> <p>ART. No :</p> <p>ΠΕΡΙΓΡΑΦΗ: ΛΑΣΤΙΧΟ ΣΦΗΝΑ 3-4 mm DESCRIPTION: GLAZING GASKET 3-4 mm</p> <p>ΥΛΙΚΟ: EPDM ΧΡΩΜΑ: ΜΑΥΡΟ MATERIAL: COLOR: BLACK</p>
	<p>ΚΩΔΙΚΟΣ : 200-05-506-00 <small>STOCK No :</small></p> <p>ART. No :</p> <p>ΠΕΡΙΓΡΑΦΗ: ΛΑΣΤΙΧΟ ΣΦΗΝΑ 5-6 mm DESCRIPTION: GLAZING GASKET 5-6 mm</p> <p>ΥΛΙΚΟ: EPDM ΧΡΩΜΑ: ΜΑΥΡΟ MATERIAL: COLOR: BLACK</p>
	<p>ΚΩΔΙΚΟΣ : 200-05-708-00 <small>STOCK No :</small></p> <p>ART. No :</p> <p>ΠΕΡΙΓΡΑΦΗ: ΛΑΣΤΙΧΟ ΣΦΗΝΑ 7-8 mm DESCRIPTION: GLAZING GASKET 7-8 mm</p> <p>ΥΛΙΚΟ: EPDM ΧΡΩΜΑ: ΜΑΥΡΟ MATERIAL: COLOR: BLACK</p>
	<p>ΚΩΔΙΚΟΣ : 200-06-860-00 <small>STOCK No :</small></p> <p>ART. No :</p> <p>ΠΕΡΙΓΡΑΦΗ: ΛΑΣΤΙΧΟ ΤΖΑΜΙΟΥ 4 mm DESCRIPTION: GLAZING GASKET 4 mm</p> <p>ΥΛΙΚΟ: EPDM ΧΡΩΜΑ: ΜΑΥΡΟ MATERIAL: COLOR: BLACK</p>
	<p>ΚΩΔΙΚΟΣ : 200-68-310-00 <small>STOCK No :</small></p> <p>ART. No :</p> <p>ΠΕΡΙΓΡΑΦΗ: ΛΑΣΤΙΧΟ ΤΖΑΜΙΟΥ ΣΥΡΤΑΡΩΤΟ 3 mm DESCRIPTION: GLAZING GASKET 3 mm</p> <p>ΥΛΙΚΟ: GUM FORPREN ΧΡΩΜΑ: ΜΑΥΡΟ MATERIAL: COLOR: BLACK</p>
	<p>ΚΩΔΙΚΟΣ : 200-11-420-00 <small>STOCK No :</small></p> <p>ART. No :</p> <p>ΠΕΡΙΓΡΑΦΗ: ΛΑΣΤΙΧΟ ΤΖΑΜΙΟΥ 7 mm DESCRIPTION: GLAZING GASKET 7 mm</p> <p>ΥΛΙΚΟ: EPDM ΧΡΩΜΑ: ΜΑΥΡΟ MATERIAL: COLOR: BLACK</p>
	<p>ΚΩΔΙΚΟΣ : 210-15-000-00 <small>STOCK No :</small></p> <p>ART. No :</p> <p>ΠΕΡΙΓΡΑΦΗ: ΛΑΣΤΙΧΟ ΚΕΝΤΡΙΚΟ DESCRIPTION: CENTRAL GASKET</p> <p>ΥΛΙΚΟ: EPDM ΧΡΩΜΑ: ΜΑΥΡΟ MATERIAL: COLOR: BLACK</p>
	<p>ΚΩΔΙΚΟΣ : 210-15-000-01 <small>STOCK No :</small></p> <p>ART. No :</p> <p>ΠΕΡΙΓΡΑΦΗ: ΛΑΣΤΙΧΟ ΚΕΝΤΡΙΚΟ DESCRIPTION: CENTRAL GASKET</p> <p>ΥΛΙΚΟ: EPDM PLUS ΧΡΩΜΑ: ΜΑΥΡΟ MATERIAL: COLOR: BLACK</p>
	<p>ΚΩΔΙΚΟΣ : 210-15-128-01 <small>STOCK No :</small></p> <p>ART. No :</p> <p>ΠΕΡΙΓΡΑΦΗ: ΛΑΣΤΙΧΟ ΚΕΝΤΡΙΚΟ DESCRIPTION: CENTRAL GASKET</p> <p>ΥΛΙΚΟ: EPDM ΧΡΩΜΑ: ΜΑΥΡΟ MATERIAL: COLOR: BLACK</p>
	<p>ΚΩΔΙΚΟΣ : 220-11-001-00 <small>STOCK No :</small></p> <p>ART. No :</p> <p>ΠΕΡΙΓΡΑΦΗ: ΛΑΣΤΙΧΟ ΚΑΣΑΣ DESCRIPTION: GASKET FOR FRAME</p> <p>ΥΛΙΚΟ: EPDM ΧΡΩΜΑ: ΜΑΥΡΟ MATERIAL: COLOR: BLACK</p>

STOCK No :	ΚΩΔΙΚΟΣ : ART. No :	220-11-001-01	
ΠΕΡΙΓΡΑΦΗ: DESCRIPTION:	ΛΑΣΤΙΧΟ ΚΑΣΑΣ GASKET FOR FRAME		
ΥΛΙΚΟ: MATERIAL:	EPDM PLUS	ΧΡΩΜΑ: COLOR:	MAYPO BLACK
STOCK No :	ΚΩΔΙΚΟΣ : ART. No :	220-11-002-00	
ΠΕΡΙΓΡΑΦΗ: DESCRIPTION:	ΛΑΣΤΙΧΟ ΦΥΛΛΟΥ GASKET		
ΥΛΙΚΟ: MATERIAL:	EPDM	ΧΡΩΜΑ: COLOR:	MAYPO BLACK
STOCK No :	ΚΩΔΙΚΟΣ : ART. No :	220-11-002-01	
ΠΕΡΙΓΡΑΦΗ: DESCRIPTION:	ΛΑΣΤΙΧΟ ΦΥΛΛΟΥ GASKET		
ΥΛΙΚΟ: MATERIAL:	EPDM PLUS	ΧΡΩΜΑ: COLOR:	MAYPO BLACK
STOCK No :	ΚΩΔΙΚΟΣ : ART. No :	220-15-001-00	
ΠΕΡΙΓΡΑΦΗ: DESCRIPTION:	ΛΑΣΤΙΧΟ ΦΥΛΛΟΥ GASKET		
ΥΛΙΚΟ: MATERIAL:	EPDM	ΧΡΩΜΑ: COLOR:	MAYPO BLACK
STOCK No :	ΚΩΔΙΚΟΣ : ART. No :	220-63-000-00	
ΠΕΡΙΓΡΑΦΗ: DESCRIPTION:	ΛΑΣΤΙΧΟ ΝΥΧΑΚΙ ΠΑΤΗΤΟ GASKET		
ΥΛΙΚΟ: MATERIAL:	EPDM	ΧΡΩΜΑ: COLOR:	MAYPO BLACK
STOCK No :	ΚΩΔΙΚΟΣ : ART. No :	230-00-959-00	
ΠΕΡΙΓΡΑΦΗ: DESCRIPTION:	ΛΑΣΤΙΧΟ ΑΡΜΟΥ ΔΙΑΣΤΟΛΗΣ GASKET FOR EXPANSION JOINT		
ΥΛΙΚΟ: MATERIAL:	EPDM	ΧΡΩΜΑ: COLOR:	MAYPO BLACK
STOCK No :	ΚΩΔΙΚΟΣ : ART. No :	250-11-170-00	
ΠΕΡΙΓΡΑΦΗ: DESCRIPTION:	ΛΑΣΤΙΧΟ ΣΤΕΓΑΝΩΣΗΣ GASKET		
ΥΛΙΚΟ: MATERIAL:	EPDM	ΧΡΩΜΑ: COLOR:	MAYPO BLACK
STOCK No :	ΚΩΔΙΚΟΣ : ART. No :	250-11-226-00	
ΠΕΡΙΓΡΑΦΗ: DESCRIPTION:	ΛΑΣΤΙΧΟ ΝΕΡΟΧΥΤΗ GASKET		
ΥΛΙΚΟ: MATERIAL:	EPDM	ΧΡΩΜΑ: COLOR:	MAYPO BLACK
STOCK No :	ΚΩΔΙΚΟΣ : ART. No :	250-11-270-00	
ΠΕΡΙΓΡΑΦΗ: DESCRIPTION:	ΛΑΣΤΙΧΟ ΣΤΕΓΑΝΩΣΗΣ GASKET		
ΥΛΙΚΟ: MATERIAL:	EPDM	ΧΡΩΜΑ: COLOR:	MAYPO BLACK

